



# SERVICE STATION MANUAL



---

## USING THIS MANUAL

This manual describes the service procedures for the Stella - 4S scooter

Follow the maintenance schedule and service procedures to keep scooter in perfect working condition and to deliver the satisfactory performance.

Initial running - in and maintenance is very important for the life of the product.

Periodic maintenance schedules given at 'Care and Maintenance' chapter is for upkeeping the scooter performance, and for its longer life.

Chapter 1 to 5 are for whole scooter and chapter 6 gives the general service details, disassembly, inspection, discard limits and assembly procedures for engine parts. The general tools and small parts are not described due to their simple operational use.

Chapter 7 gives the general service details of important only for the chassis.

Chapter 1 gives technical features of scooter.

If you do not know source of trouble go to chapter 8, "Trouble Shooting".

ALL INFORMATION, DETAILS AND SPECIFICATIONS OF PARTS GIVEN IN THIS SERVICE MANUAL ARE BASED ON THE LATEST INFORMATION AVAILABLE AT THE TIME OF INSTRUCTIONS FOR WRITING THIS MANUAL.

LML RESERVES THE RIGHT TO MAKE CHANGES AT ANY TIME WITHOUT ANY PRIOR NOTICE AND WITHOUT ANY OBLIGATION.

NO PART OF THIS MANUAL CAN BE REPRODUCED WITHOUT WRITTEN PERMISSION.

THIS MANUAL IS FOR THE TECHNICIANS WHO HAVE THE BASIC KNOWLEDGE OF MAINTENANCE ON GENUINE SCOOTERS.

CUSTOMER CARE  
GENUINE SCOOTERS

**INDEX**

	<b>PAGE No.</b>
<b>1. GENERAL INFORMATION</b>	<b>5</b>
<b>2. CARE AND MAINTENANCE</b>	<b>23</b>
<b>3. LUBRICATION SYSTEM</b>	<b>43</b>
<b>4. FUEL SYSTEM</b>	<b>53</b>
<b>5. SPECIAL SERVICE TOOLS</b>	<b>63</b>
<b>6. ENGINE</b>	<b>73</b>
<b>ENGINE REMOVAL / INSTALLATION</b>	<b>74</b>
<b>CYLINDER HEAD / VALVES</b>	<b>79</b>
<b>CYLINDER / PISTON</b>	<b>97</b>
<b>CLUTCH ASSEMBLY</b>	<b>105</b>
<b>MAGNETO ASSEMBLY</b>	<b>119</b>
<b>TRANSMISSION</b>	<b>123</b>
<b>Gear Control Bracket and Kick Lever</b>	<b>124</b>
<b>Crank Case Halves Separation</b>	<b>128</b>
<b>Starter Sector and Kick Spring</b>	<b>129</b>
<b>Drive Shaft</b>	<b>131</b>
<b>Counter Shaft</b>	<b>136</b>
<b>Crank Shaft</b>	<b>138</b>
<b>Bearing Replacement in Crank Case</b>	<b>141</b>
<b>Crank Case Assembly</b>	<b>145</b>
<b>7. CHASSIS</b>	<b>149</b>
<b>LINK ASSEMBLY</b>	<b>151</b>
<b>FRAME</b>	<b>153</b>
<b>FRONT BRAKE DRUM</b>	<b>159</b>
<b>FRONT SUSPENSION</b>	<b>168</b>
<b>STEERING COLUMN</b>	<b>173</b>
<b>8. TROUBLE SHOOTING</b>	<b>177</b>
<b>CHECK SEQUENCE</b>	<b>178</b>
<b>TROUBLE SHOOTING - PROBLEMS</b>	<b>181</b>

**GENERAL INFORMATION****INDEX**

	<b>PAGE No.</b>
SERVICE RULES	5
VEHICLE IDENTIFICATION	8
TECHNICAL SPECIFICATION	9
SPECIFICATIONS FOR SERVICE	13
SPECIFIED TORQUE VALUES	16
CONTROL CABLES	18
WIRING HARNESS	19
WIRING DIAGRAMS	20

**GENERAL SERVICE DETAILS**

1. Use only genuine spare parts, recommended lubricants at specified points.
2. Use only metric nuts and bolts (MKS system).
3. Use proper tools designed for this scooter to avoid damage and incorrect assembly.
4. Install new gasket, 'O' rings, oil seals, clips and split pins while reassembling.
5. Clean parts for measurements and get rid of contaminated oil, if any. Lubricate working parts lightly by oil while assembling.
6. When engine and transmission components are dismantled and kept for a longer period, coat the mating surfaces with a lubricant to prevent rusting and cover them to avoid dust.
7. After reassembling, check all nuts and bolts for proper tightening by torque wrench, check all parts for proper installation and operation.
8. Control cables and wiring harness are to be routed properly. Always keep the cables away from sharp edges and corners where they may get damaged.

## GENERAL INFORMATION

---

### SAFETY FIRST !

Scooter mechanics are professionally trained to follow safe working procedures. A moment's lack of attention or failure to observe certain elementary precautions can result in an accident.

#### **WARNING**

**Fire** : Remember that the petrol is highly flammable. Never smoke or any kind of naked flame in the workshop. Proper care has to be taken for electrical short circuiting as this can ignite petrol vapour.

Always disconnect the battery ground terminal before working on the fuel and electrical system. Never risk spilling petrol on a hot engine or exhaust.

It is recommended that a suitable fire extinguisher for fuel and electrical fires is kept handy in the workshop. Never try to extinguish a fuel or electrical fire with water.

#### **WARNING**

**Fumes** : Certain fumes are highly toxic and can quickly cause unconsciousness and even death if inhaled.

Never run the engine of a vehicle in enclosed space as exhaust fumes contain carbon mono-oxide which is extremely poisonous. If you need to run the engine, always do so in open air or have the rear portion of the vehicle outside of the work place. It is better allow an exit for exhaust smoke through a pipe and have air ventilation in the workshop.

#### **WARNING**

**Battery** : Take care while topping up the distilled water in the battery as the electrolyte is very corrosive.

The electrolyte should not come in the contact with eyes or skin.

**ELECTRICALS SAFETY**

1. A loose wire harness can be a safety hazard. After clamping, check each wire to be sure it is secure.
2. Don't curve clamps towards welds.
3. Secure wire bands to the frame at the designated locations. Tighten the wire bands (strap) so that the insulated surfaces can contact the wire harnesses.
4. Route wire harnesses and cables to avoid touching frame ends or sharp edges.
5. Route wire harnesses to avoid the projected ends of bolts and screws.
6. Keep wire harnesses and cables away from the hot parts or area where they might be pinched between the moving parts.
7. Wire harnesses routed along the handlebars should not be pulled tight or have excessive slack or be pinched or interfere with adjacent or surrounding parts in all steering positions.
8. Check that the wire harnesses are not twisted or kinked.
9. Ascertain if there is a damage of connector cover, and if its terminal is opened excessively, before connection.
10. Protect wires and harnesses with tape or a tube if they contact a sharp edge or corner.
11. After repairing wire harness, wrap with protective tape or replace them.
12. Be sure grommets are seated in their grooves properly.
13. Don't bend or twist the control cables. Damaged control cables will not operate smoothly and may stick or bind.

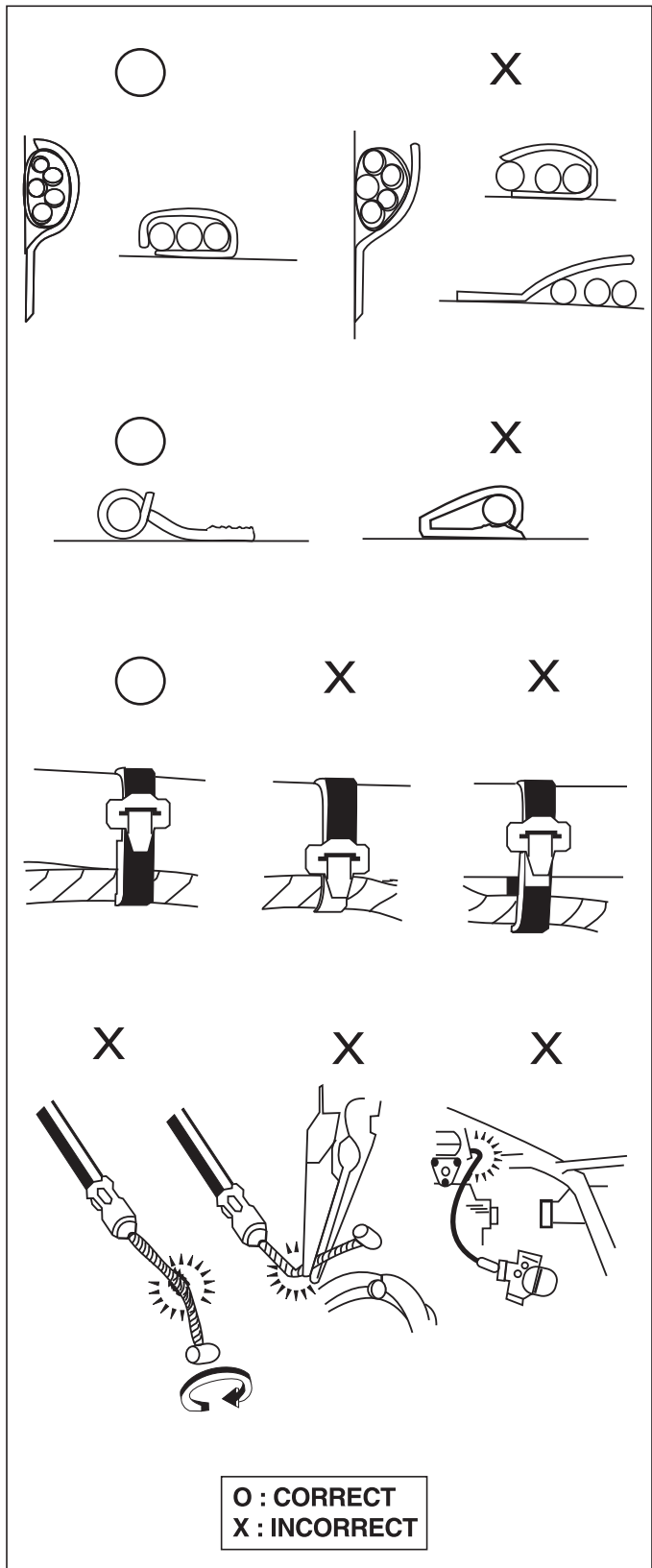

## GENERAL INFORMATION

---

### VEHICLE IDENTIFICATION

The vehicle is identified by a number on the chassis and another number on the engine.

The chassis identification number is stamped inside the glove compartment on upper chassis. Chassis number has the prefix C9XX followed by 6 digit numbers.

Fig. A



Fig. A

The engine number is stamped on the crank case. The engine number has the prefix E24XX followed by 6 digit numbers.

Fig. B



Fig. B

Each **LML 4 STROKE** has one set of duplicate keys. It has an identification number provided on the tag in the ring given for the keys. Please keep your duplicate key carefully.

Fig. C

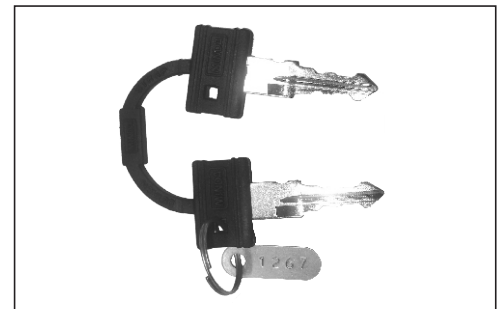

Fig. C

**TECHNICAL SPECIFICATIONS**

**Dimensions**

Overall length 1760mm

Overall width 695mm

**Wheel base** 1235mm

Maximum road clearance 160mm

Seat height 820mm

**Weights**

Vehicle kerb weight (with 90% fuel) 116kgs for kick start scooter and 120kgs for electric start

Maximum carrying capacity 2 Persons & 20 kgs of luggage - 286 kg.

**Engine**

Single cylinder, four stroke, forced air cooled with Single over head cam and 2 valves

Displacement 147.55 cc

Bore 57.0 mm

Stroke 57.8 mm

Compression ratio 9:1

Idling speed 1200 ± 100 rpm

Maximum output/Power (8.3 ± 0.3 Bhp)at 6250 rpm.

Maximum torque 1.1 kgm at 4250 rpm.

Ignition system Capacitor Discharge Ignition (CDI) Electronic.

Ignition timing 12°–25° ± 2° before TDC

**Valve Train**

Inlet Valve Open 2.5° ATDC

Closes 30° ABDC

Exhaust Valve Opens 30° BBDC

Closes 2.5° BTDC

Oil Pump Type Trochoidal

Oil Filtration System By strainer and paper element filter

Cooling System Forced air cool

Air Filtration By Polyurethane Elements

**Fuel**

Petrol 87 Octane and above

Fuel tank capacity 5.5 liters (inclusive of 1 liter in reserve)

Fuel cock Three way tap

Open (ON), Close (OFF), Reserve (RES)

**Carburettor**

KEHIN PB18-side draft

**Spark Plug**

RG4HC - Champion

UHR3CC - MICO BOSCH

Spark plug gap 0.7-0.8 mm

**Starting**

Kick Start, Push Button for Auto start

**Clutch**

Multiplate, oil bath.

**Transmission**

4 Speed constant mesh



## GENERAL INFORMATION

---

### Overall Gear Ratio

1st Gear	17.07 : 1
2nd	10.71 : 1
3rd	7.89 : 1
4th	5.83 : 1

### Chassis

Semi Monocoque structure having pressed steel sheet in front and tubular frame in rear, Covered by sheet metal shell assembly.

### Steering column and suspension

The steering column is pivoted at the front wheel swinging hub.

### Front and rear suspension

Front and rear suspension with hydraulic dampers and helical spring

### Brakes

#### Front brake

Drum brake, mechanical expanding shoe type.

Disc brake (optional)

#### Rear brake

Drum brake, mechanical expanding shoe type.

### Tyres

#### Front and rear tires

89x254mm (3.50x10), 4 ply rating, interchangeable

### Tyre pressure

#### Front wheel

1.2 kg/cm<sup>2</sup> (17 psi)

#### Rear wheel

1.8 kg/cm<sup>2</sup> (25 psi)

2.5 kg/cm<sup>2</sup> (35 psi) with pillion rider

### Controls

#### Steering

Handle bar

#### Accelerator

Twist grip type on right hand side of the handle bar

#### Gears

By hand on left hand side of the handle bar

#### Clutch

Lever operated on left hand side of the handle bar

#### Front brake

Lever operated by right hand

#### Rear brake

Pedal operated by right foot

### Electronic

#### Generator system

12 Volt 96 Watt

#### Head lamp

12 Volt 35/35 Watt

#### Tail light bulb

12 Volt 5 Watt

#### Stop light bulb

12 Volt 10 Watt / 21 Watt (DOM)

#### Speedo light bulb

12 Volt 1.2 Watt x 2

#### Turn signal light bulb

12 Volt 10 Watt / 21 Watt (DOM)

#### Tell tale lamp

12 Volt 1.2 Watt x 4

#### Horn

12 Volt DC Horn fitted with AC to DC converter

#### Battery

12 Volt 9 Ah (for auto start model)

#### Fuse

8 Amp. (for auto start model)

### Maximum speed

90 kms./hr.

## GENERAL INFORMATION

### CYLINDER / PISTON

ITEM		STANDARD			Service Limit
		B	C	D	
Cylinder (BCD grades only)	Cylinder Bore	57.020 - 57.025 mm	57.015 - 57.020 mm	57.010 - 57.015 mm	57.10
	Piston	Piston O.D	56.985 - 56.980 mm	56.980 - 56.975 mm	56.975 - 56.970 mm
Piston pin	Cylinder-to-piston clearance	0.035 - 0.045 mm	0.035 - 0.045 mm	0.035 - 0.045 mm	0.09
	Piston pin hole I.D	14.003 - 14.009 mm			14.021
Piston pin	Piston pin O.D	13.996 - 14.000 mm			13.983
Piston ring	Piston ring-to-groove	Top	0.015 - 0.05 mm		0.08
		Second	0.015 - 0.045 mm		0.08
	Piston ring end gap	Top Ring	0.15 - 0.30 mm		0.45
		Second Ring	0.30 - 0.45 mm		0.45
		Oil ( Side rail )	0.20 - 0.70 mm		--1.1

for cylinder ovality, taper and warpage service limit is 0.05 mm

### CLUTCH / CRANK SHAFT

ITEM		STANDARD
Clutch	Lever free play	2.0 mm
	Spring free length / No. of turns	8.0 <sup>+0.5</sup> / <sub>-1.5</sub> / 5.75 Turns
	Disc clutch friction thickness	3.0 mm
Crank Shaft	Bigend radial clearance	2 to 12 microns
	Bigend (con. rod) side clearance	0.05 - 0.30 mm

### SOME IMPORTANT STANDARD DIMENSIONS (ENGINE)

#### CYLINDER HEAD / VALVES

ITEM		STANDARD	Ser. Limit	
Cylinder compression		10.0 ± 2.0 kg.cm <sup>2</sup>	-	
Valve clearance (cold)	Inlet	0.06 ± 0.01 mm	-	
	Exhaust	0.08 ± 0.01 mm	-	
Camshaft Cam lobe height		Inlet / Exhaust	29.488 - 29.493 mm	29.448-29.453
Valve	Stem O.D.	Inlet	4.975 - 4.990 mm	4.9
		Exhaust	4.955 - 4.970 mm	4.9
	Guide I.D.	Inlet	5.00 - 5.017 mm	5.03
		Exhaust	5.001 - 5.017 mm	5.03
	Stem-to-guide clearance	Inlet	0.010 - 0.042 mm	0.08
		Exhaust	0.030 - 0.062 mm	0.10
Spring free length (Inner / Outer)		30.66 - 33.66		
Valve seat width		0.9 - 1.1 mm		1.5
Cylinder head warpage		0.05 mm Max		-

## GENERAL INFORMATION

### PRECAUTION

- (a) Do not interchange top & second piston ring.
- (b) Avoid open end of any piston ring coming inline with piston pin boss.
- (c) Always ensure that  $180^\circ$  angle between open end gap of top and second ring and  $90^\circ$  to  $120^\circ$  angle between open end gap of top side rail and bottom side rail.
- (d) Cover the crank case opening with a clean cloth to prevent the piston pin clip falling into the crank case.
- (e) Ensure proper fitment of clip - piston pin after installing it in the groove move away the open end from the gate.

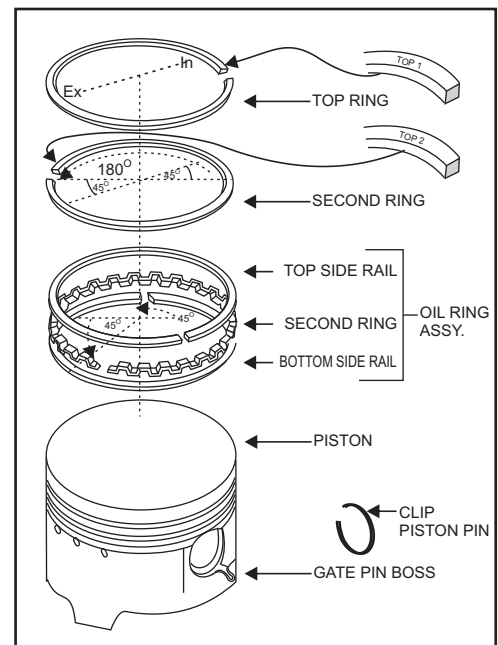

**SPECIFICATIONS FOR SERVICE**

S.No.	CRITERIA	SPECIFICATION
1	Clutch lever play	2 to 3 mm
2	Fr. Brake Lever play	5 mm
3	Rr. Brake Lever Play	5 mm
4	Throttle play	2 to 3 mm (radially)
5	Recommended Engine Oil of reputed make	20W40 Multigrade
6	Engine oil capacity	
7	To be filled	850 ml
8	On drain	750 ml
9	Valve clearance (tappet setting)	
10	Inlet	0.06 ± 0.01 mm
11	Exhaust	0.08 ± 0.01 mm
12	Spark plug gap	0.7 to 0.8 mm
13	Engine idle speed	1200 rpm ± 100 rpm
14	Cold tyre pressure	
	Driver only	Front Tyre 1.2 Kg/Cm <sup>2</sup>
		Rear Tyre 1.8 Kg/Cm <sup>2</sup>
	Driver and Pillion Rider	Front Tyre 1.2 Kg/Cm <sup>2</sup>
		Rear Tyre 2.5 Kg/Cm <sup>2</sup>
15.	Tyre Size Front and Rear	89 x 254 mm (3.5 x 10") 4 ply rating interchangeable

## GENERAL INFORMATION

---

### LIST OF DOWELS - ROLLERS - BEARING AND OIL SEALS IN THE ENGINE

#### DOWELS

SL. NO.	SIZE (mm)	QTY.	DESCRIPTION	LOCATION	PART NO.
1	8x12	2	Dowel	Clutch cover	SF504-1175
2	10x16	2	Dowel	Cylinder block	SF504-1164
3	12 x 20	2	Dowel	Cylinder head	SF504-1177
4	10 x 16	2	Dowel	Crank case	SF504-1164
5	8x12	2	Dowel	Gear control bracket	SF504-1175

#### ROLLERS

SL. NO.	SIZE (mm)	QTY.	DESCRIPTION	LOCATION	PART NO.
1	4x8	1	Roller	Crank shaft assy.	SF514-0035
2	2.5x11.8	1	Roller	Oil Pump	SF504-1194

#### BEARINGS

SL. NO.	SIZE (mm)	QTY.	DESCRIPTION	LOCATION	PART NO.
1	25x68x12	2	Ball bearing	Crank shaft assy.	SF503-1003
2	28.58x34.9x12.7	1	DC roller bearing	Drive shaft	SF504-1004
3	16x22x16	1	Needle roller bearing	Spring gear assy.	SF514-0100
4	14x20x12	1	Needle roller bearing	Idler gear	SF514-0075
5	6202-C3 (15x35x11)	1	Ball bearing	Cam shaft	C-4770969
6	600-ZC3 "NtN" (15x32x9)	1	Ball bearing	Cam shaft	C-4770922
7	20x47x14	1	Ball bearing	Drive shaft	SF504-1012
8	15x42x13	1	Ball bearing	Spring gear assy.	SF504-1002
9	10 x 13 x 13	2	Roller bearing	Rocker arm shaft	SF514-0140

#### OIL SEALS

SL. NO.	SIZE (mm)	QTY.	DESCRIPTION	LOCATION	PART NO.
1	16x24x7	1	Oil seal	Starter sector	SF514-0019
2	20x30x7	1	Oil Seal	Flywheel side	SF514-0060
3	27x42x10	1	Oil seal	Drive shaft	SF514-0183

---

**GENERAL INFORMATION****LIST OF STUDS USED IN ENGINE**

<b>S. No.</b>	<b>LOCATION</b>	<b>PART NO.</b>	<b>QTY.</b>	<b>SIZE (MM)</b>	<b>HEIGHT TO BE KEPT ABOVE SURFACE (MM)</b>
1	Stud cylinder (cap nuts)	SF514-0057	4	M8 x 199	170.0
2	Stud cylinder	SF514-0089	2	M6 x 96.5	83.0
3	Crank case halves joining	SF504-1024	5	M7 x 50	35.0
4	Holding exhaust pipe cylinder head	C-4770745	2	M6 x 40	25.0
5	Housing paper filter	C-4770745	1	M6 x 40	25.0
6	Clutch cover	C-4770745	1	M6 x 40	25.0
7	Gear control bracket to crank case	SF514-0192	2	M6 x 55	34.0
8	Rear brake drum	C-4703110	5	M8 x 31	16.5

## GENERAL INFORMATION

### SPECIFIED TORQUE VALUES

It is most important for the components/fastners to be tightened as per specified torque value as given below. The technician should be well conversant with the use of metric torque wrench.

S. No.	DESCRIPTION	QTY. IN NOS	TORQUE (Kg-m)
<b>ENGINE GROUP</b>			
	Cylinder Head Assembly :		
1	Timing sprocket cover bolt	2	1.2
2	In./Ex. Tappet Inspection Cover bolt	2+2	1.2
3	Cylinder Head Dome Nut	4	2.9
4	Nut for Securing Head	2	1.1
5	Silencer Securing Nut	2	1.8
6	Timing Sprocket (19T) Mounting Bolt	1	1.8
7	Timing Chain Lifter Tensioner Mounting bolt	2	1.2
8	Timing Chain Tensioner Guide Pivot Bolt	1	1.0
9	Spark Plug	1	1.1
10	Screw for plate Rocker Arm Shaft	1	0.9
<b>CRANK CASE</b>			
1	Oil Filter Screen Cap	1	1.5
2	Crank Case Nuts	14	1.6
3	Drain Plug	1	3.2
4	Flywheel Magneto Nut	1	6.5
5	Fan Cover Bolts	3	1.1
6	Clutch Lock Nut	1	4.2
7	Oil Filter Cover Nuts	4	1.1
8	Oil Pump Screws	3	1.1
9	Stator Coil Stack Securing Screws	3	0.4
10	Pickup Securing Screw	2	0.25
11	Inlet manifold securing bolts	2	1.1
12	Carburettor Securing Bolts	2	1.1
13	Starter Motor mounting nuts	3	1.5
14	Kick Starter Lever mounting nuts	1	2.5
15	Clutch Cover Bolts	6	1.1
16	GCB nuts	2	1.6
17	GCB Cover Mtg. Bolt	1	1.1

## GENERAL INFORMATION

S. No.	DESCRIPTION	QTY. IN NOS.	TORQUE (Kg-m)
<b>FRONT SUSPENSION UNIT</b>			
1	Hub for Securing Damper Nut	2	2 to 2.7
2	Damper Upper Retaining Nut	1	3 to 4
3	Damper Lower Retaining Nut	2	2 to 2.7
<b>REAR SUSPENSION UNIT</b>			
1	Bolt for Securing Engine to Link	1	6 to 7.5
2	Bolt for Securing Link to Chassis	1	5 to 6
3	Damper Lower Part Securing Nut	1	3.0 to 3.5
4	Damper Upper Part Special Bolt	1	2.5 to 2.7
<b>STEERING UNIT</b>			
1	Steering Column Upper Bearing	1	5 to 6
2	Steering Column Upper Bearing Nut	1	3 to 4
3	Handle bar Securing Bolt	1	3 to 4.4
<b>WHEEL UNIT</b>			
1	Rear Wheel Shaft Securing Nut		9 to 10
2	Nut for Securing Front and Rear Wheel Rims to Drum		2 to 2.7
3	Front Wheel Axle Securing Nut		7.5 to 9
<b>GENERAL</b>			
1	5 m.m. Bolt, Nut		0.5
2	6 m.m. Bolt, Nut		1.0
3	8 m.m. Bolt, Nut		2.2
4	10 m.m. Bolt, Nut		3.5
5	12 m.m. Bolt, Nut		5.5
6	5 m.m. Screw		0.4
7	6 m.m. Flange Screw		0.9
8	6 m.m. Flange Bolt, Nut		1.2
9	8 m.m. Flange Bolt, Nut		2.7
10	10 m.m. Flange Bolt, Nut		4.0



# GENERAL INFORMATION

## CONTROL CABLES

### CONTROL CABLES LAYOUT

- A. Gear Control Cables
- B. Speedometer Cable
- C. Rear Brake Cable
- D. Choke Cable
- E. Clutch Control Cable
- F. Throttle Control Cable
- G. Front Brake Cable

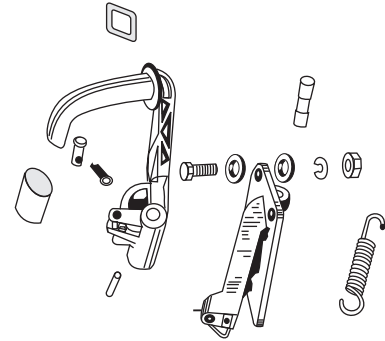
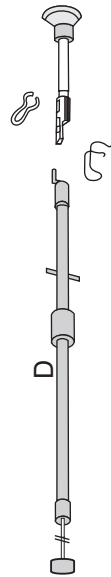
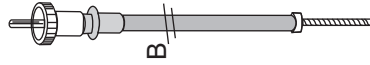
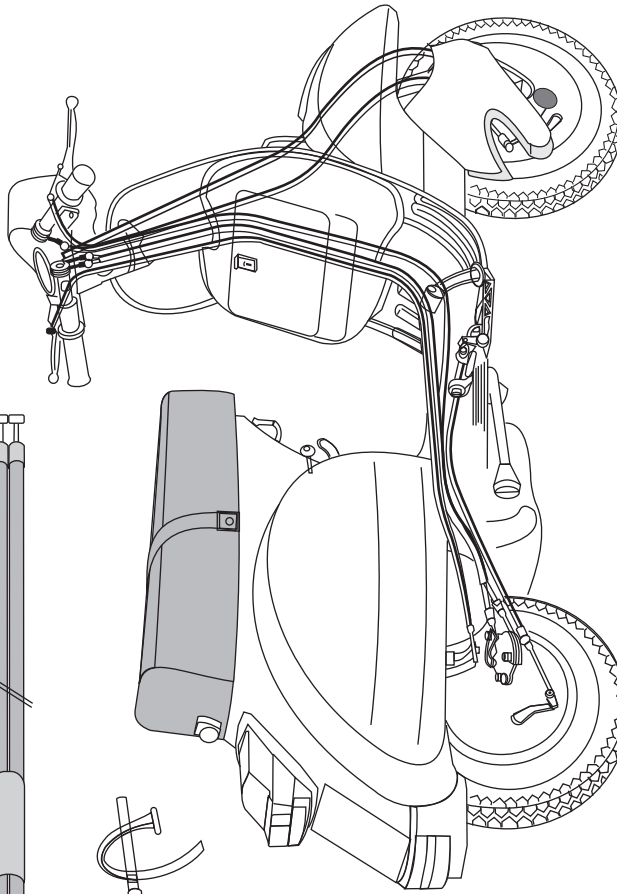
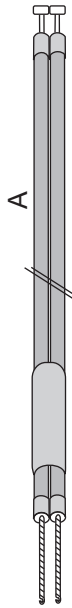
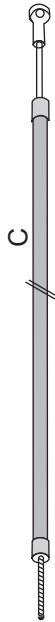

ELECTRIC WIRING HARNESSES

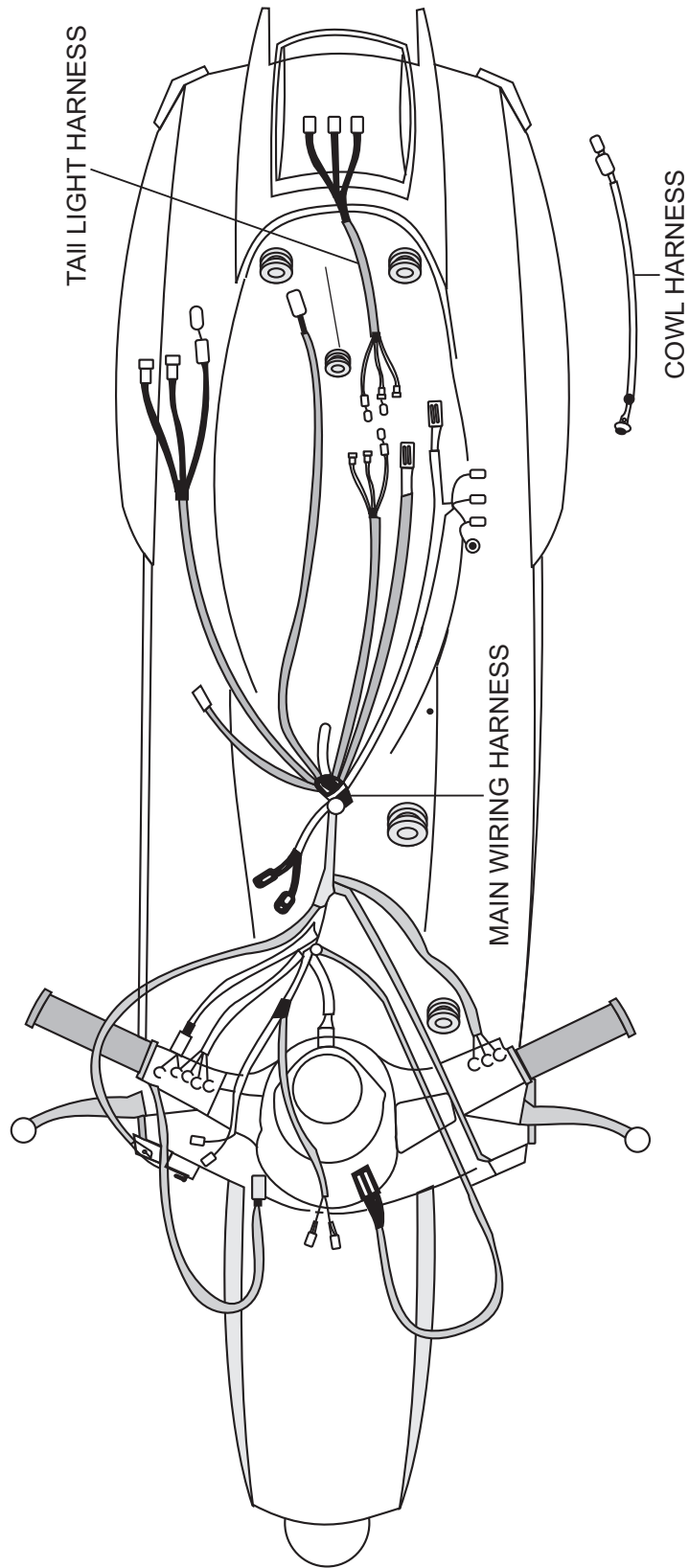

# GENERAL INFORMATION

## WIRING DIAGRAM AUTO START MODEL

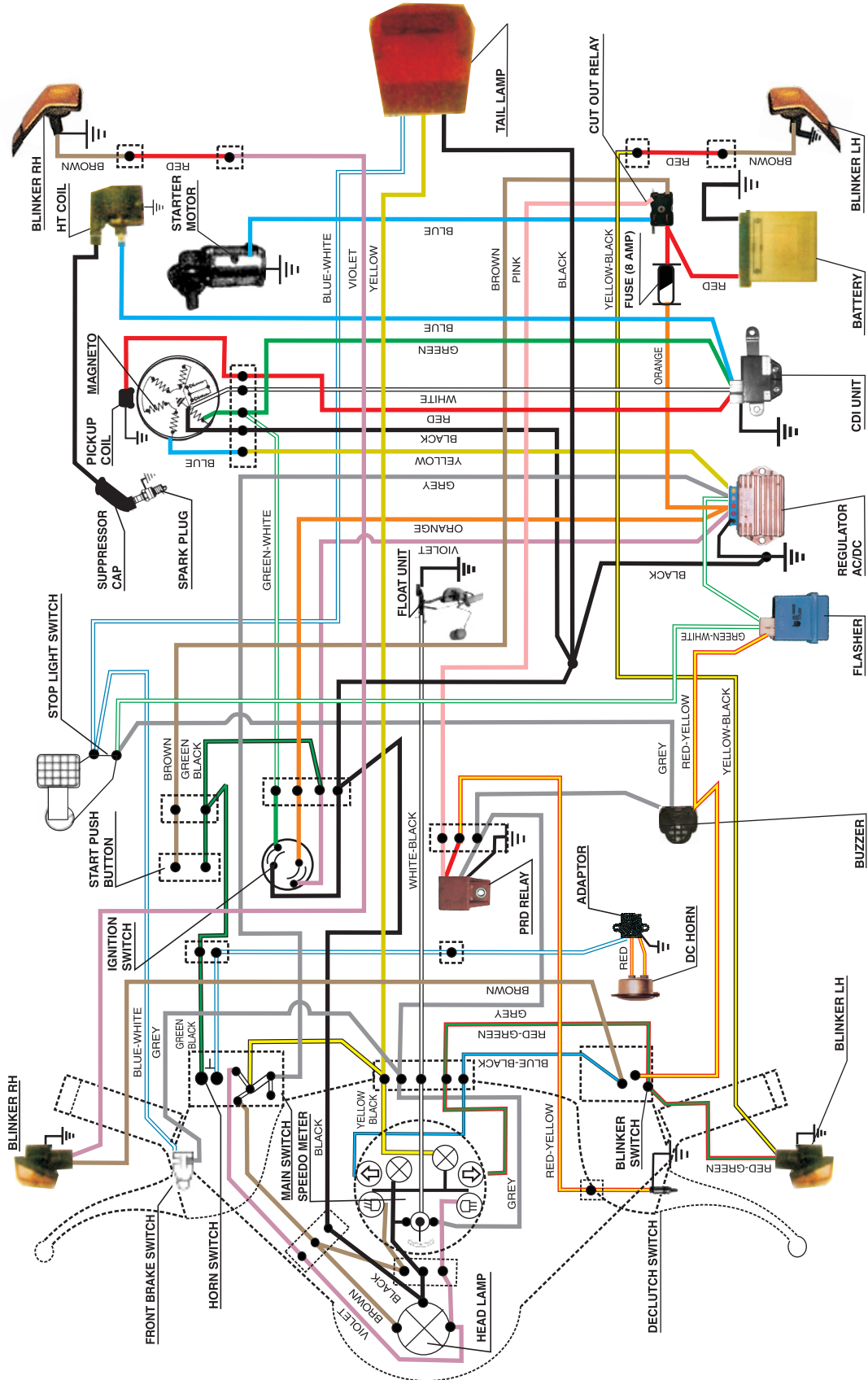

# WIRING DIAGRAM KICK START MODEL

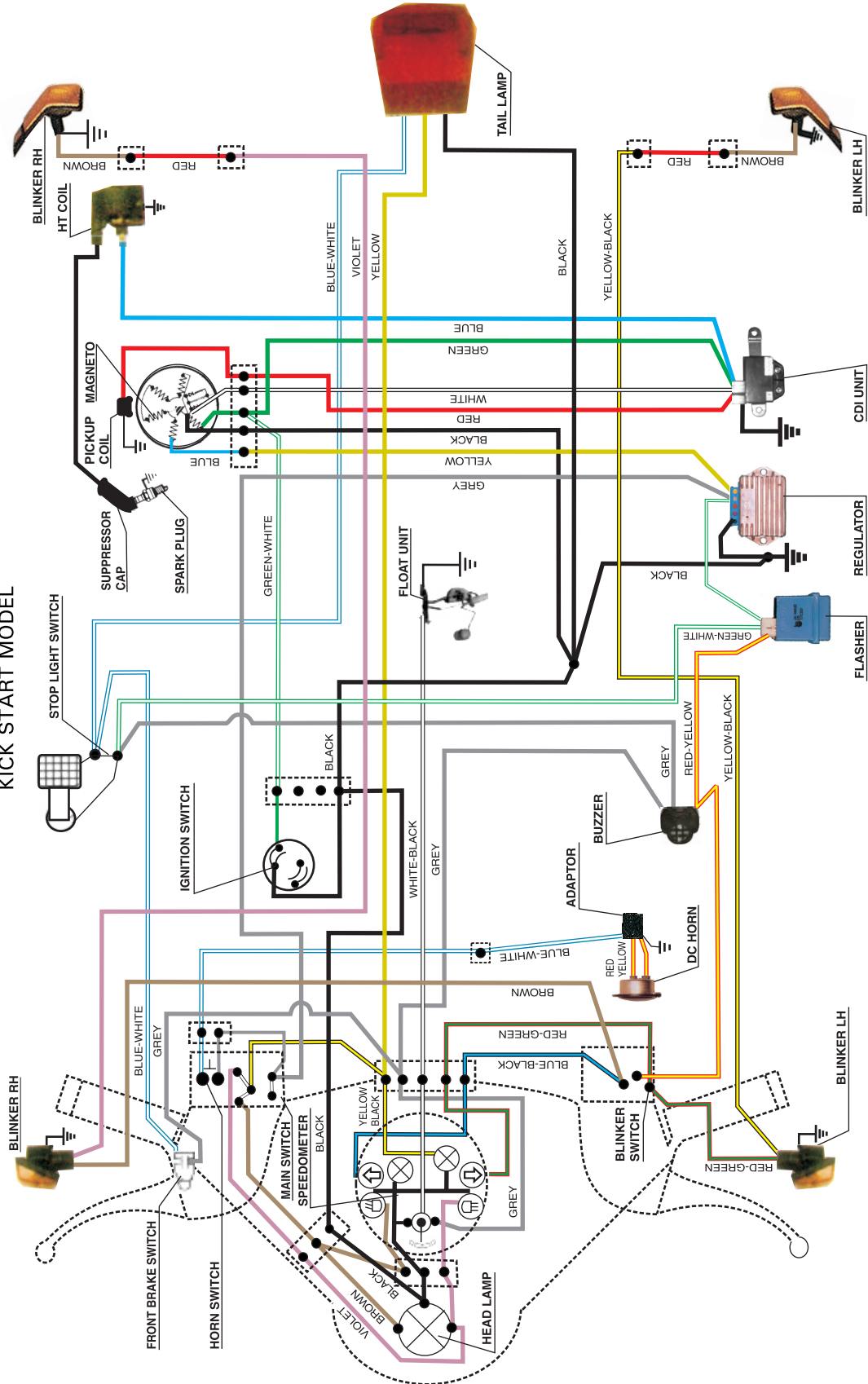

---

## CARE AND MAINTENANCE

### INDEX

DESCRIPTION	PAGE No.
GENERAL SERVICE DETAILS	23
PERIODIC MAINTENANCE	24
WASHING AND CLEANING	26
OIL LEVEL CHECKING	26
CHANGE OF ENGINE OIL	26
CLEANING OF AIR FILTER AND ELEMENTS	27
FUEL LINE	28
FUEL STRAINER IN FUEL COCK AND ON LINE FILTER	28
CRANK CASE BREATHER	28
VALVE CLEARANCE SETTING	29
CHOKE OPERATION	30
ENGINE IDLE SPEED	30
CDI, CHARGING COIL, PICK UP COIL	31
ELECTRONIC PARTS, INSTRUMENTS AND STARTER MOTOR	33
ENGINE COMPRESSION TEST	40
SPARK PLUG	41

### GENERAL SERVICE DETAILS

The vehicle should be placed on a level ground position before starting any kind of work.

Always run the engine in an open space or with an 'exhaust evacuation system' in an enclosed area, as the exhaust smoke contains poisonous carbon mono-oxide gas that may cause loss of consciousness and may lead to death, if inhaled in large amount.

**PERIODICAL MAINTENANCE BY AUTHORISED SERVICE DEALER**

Preventive Maintenance:

In order to get best performance from LML 4 Stroke Scooter, it is important to undertake maintenance of your vehicle periodically. The table gives the suggested action for different items of maintenance and their periodicity.

Code of suggested action is:

**C** - Check

**I** - Inspect, check and adjust

**F** - Drain and refill with fresh oil

**R** - Replace

**L** - Lubricate

**T** - Check and top up if necessary

**D** - Carry out

S. No.	ITEM	750-1000 kms.	3000-3500 kms.	6500-7000 kms.	10000-10500 kms.	13500-14000 kms.	17000-17500 kms.	20500-21000 kms.	23500-24000 kms.	26500-27000 kms.	29500-30000 kms.	Every 3000 km their after
1.	Washing and cleaning	D	D	D	D	D	D	D	D	D	D	D
2.	Engine Oil	F	Check level every 1000 kms and top up/if required. First oil change in new engine is required to be done after initial of 750 kms. then change Engine Oil every 3000 kms.								R	R
3.	Engine oil filter screen	D	D	D	D	D	D	D	D	D	D	D
4.	Tightening of all external nuts and bolts (Also cylinder head)	I	I	I	I	I	I	I	I	I	I	I
5.	Spark plug	I	I	I	R	I	I	R	I	I	R	+
6.	Oil pump functioning	C	C	C	C	C	C	C	C	C	C	C
7.	Engine oil filter element	R	Replace with engine oil at every 3000 kms								R	R
8.	Air cleaner and its elements washing in Kerosene as given at page no. 39	D	D	D	D	D	D	D	D	D	D	D
9.	Fuel line and carburettor cleaning			D		D	D	D	D	D	D	D
10.	Carburettor tuning check emission level	I	I	I	I	I	I	I	I	I	I	I
11.	Valve Clearance	I	I	I	I	I	I	I	I	I	I	I
12.	Functioning of electrical and electronic systems	I	I	I	I	I	I	I	I	I	I	I
13.	Battery (Top up & checkup)	D	D	D	D	D	D	D	D	D	D	D
14.	Control cable adjustment	I	I	I	I	I	I	I	I	I	I	I
15.	Brake operation & shoe wear	I	I	I	I	I	I	I	I	I	I	I
16.	Clutch operation & free play	I	I	I	I	I	I	I	I	I	I	I
17.	Front and rear shocker	C	C	C	C	C	C	C	C	C	C	C
18.	Tyre rotation & change of face			D		D		D		D		D*
19.	Lubricate: Gear control assembly Speedo drive gear Front wheel bearing Steering column bearing Main stand Clutch lever, Brake lever Brake pedal and Brake cable	L	L L	L L	L L	L L	L L	L L	L L	L L	L L	L L
20.	Clean crankcase breather tube		D	D	D	D	D	D	D	D	D	D
21.	Adjust headlight	I	I	I	I	I	I	I	I	I	I	I

**Caution :** 1. Clean air filter located below fuel tank / more frequently when riding in dusty areas for better performance and longer life of engine.  
 2. Non-adherence to schedule may reduce engine / vehicle life substantially.  
 + Spark plug replacement at every 10,000 kms.  
 \* Tyre rotation every 6000 Kms.

## CARE & MAINTENANCE

### SPECIFICATIONS FOR SERVICE

CRITERIA		SPECIFICATIONS	
Throttle play		2 - 3 mm (radially)	
Spark plug		CHAMPION	RG4HC
		NGK	C8EH9
		MICO BOSCH	UHR3CC
Spark plug gap		0.7 - 0.8 mm	
Valve clearance		INLET	0.06 ± 0.01 mm
		EXHAUST	0.08 ± 0.01 mm
Recommended engine oil		20W40 of any reputed company	
Engine oil capacity		850 ml.	
Engine idle speed		1200 ± 100 rpm	
Front brake lever play		5 mm.	
Rear brake lever play		5 mm.	
Clutch lever play		2 - 3 mm.	
Cold tyre pressure	Driver only	Front tyre	1.2 kg. / cm.sq.
		Rear tyre	1.8 kg. / cm.sq.
	Driver and pillion rider	Front tyre	1.2 kg. / cm.sq.
		Rear tyre	2.5 kg. / cm.sq.
Tyre size Front and Rear		89x254mm (3.5 x 10") interchangeable	

### TORQUE VALUES

Spark plug	<b>1.1 kg-m.</b>
Engine oil drain plug	<b>3.2 kg-m.</b>

## CARE & MAINTENANCE

### WASHING AND CLEANING:

- (a) Frequent and thorough cleaning of scooter will further enhance its appearance and extend its life.
- (b) The scooter should be cleaned at ambient temperature i.e. not immediately after use or when parked in hot sun.
- (c) Use a low pressure water hose for cleaning the scooter. Keep the air filter plugged to avoid water entry.
- (d) Wipe, clean and dry with soft cloth.
- (e) Do not use detergent or powder which are likely to leave scratches on the surface. They may also cause fading of colour.
- (f) Always use a normal wax polish and rub with a soft cloth.

### ENGINE OIL

#### CHECKING OIL LEVEL:

- (a) Park the vehicle on a level surface.
- (b) Remove the right hand side cowl.
- (c) To check the oil level, unscrew dipstick shown by 1 (fig.A) and clean it with cloth. Dip again without screwing the dip stick. Take out dipstick and check the level. Oil should be in between higher and lower level marks on dipstick.
- (d) Top up the oil to the specified level, if it is less.
- (e) Replace 'O' ring, if damaged.
- (f) Screw back the dipstick.

#### CHANGE OF ENGINE OIL: First Engine oil change should be carried out at completion of 750 kms run of vehicle.

- (a) Engine oil should be change after every 3000 Kms run of vehicle.
- (b) Drain the oil completely, by un-screwing drain plug.
- (c) **Flushing:** Fill 100 ml. fresh oil; start engine and run for 1 minute. Drain out the oil.
- (d) **Refilling:** fill the oil 20W-40 of reputed make Qty. 850 ml. through filling hole (1) to the specified level and check using dipstick Fig. A.
- (f) Wipe off any excess oil which may have spilled.
- (g) Start the engine to warm up for 2-3 minutes. Recheck the oil level
- (h) Refit the cowl.

#### NOTE:

To avoid leakage of oil from engine packing of drain bolt and 'O' ring of dipstick must be replaced, if damaged.

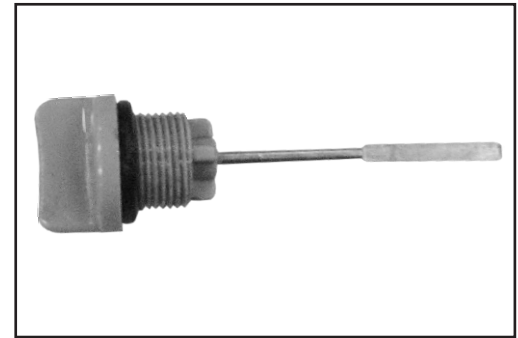

Fig. A

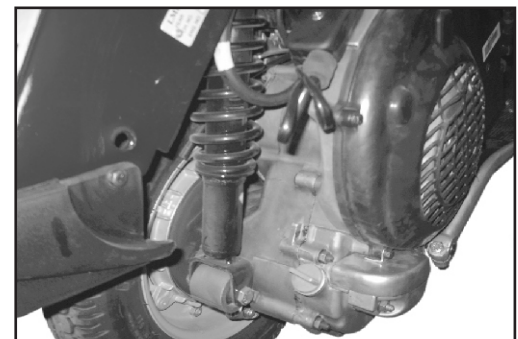

Fig. B

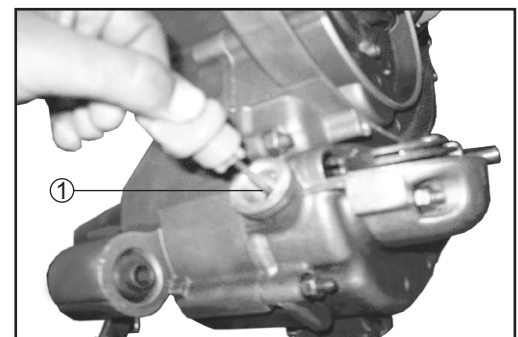

Fig. C



**CLEANING OF AIR FILTER AND ELEMENTS**

To access the air filter assy. open LH side cowl. Air filter assy. is located below fuel tank.

Open spare wheel from its bracket.

Open rear shock absorber lower bolt (Engine side).

When only elements are to be cleaned then only 4 screws of air filter lid area are to be opened. After opening lid screws take out lid gasket, PU foam element along with flame protector box.

Fig. A

Wash element in kerosene or any other solvent of high flash point and squeeze out. Do not twist to remove the solvent.

Soak in fresh 20W40 oil and squeeze out extra oil.

Fig. B

For opening Air cleaner box first open bellow clamp screw at carburettor end. Open rear brake drum and 3 bolts, holding Air cleaner box to Engine.

Fig. C, D and E

Clean box and bellow with a foam, wet in solvent from inside.

Installation is to be done in reverse order of opening.

Be careful for proper sealing of gasket to avoid infiltration of dust/dirt.

Tighten rear shock absorber with 3.0 kg-m torque.

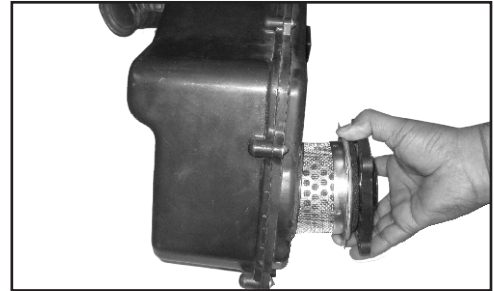

Fig. A

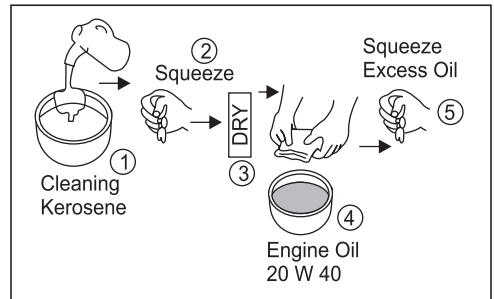

Fig. B

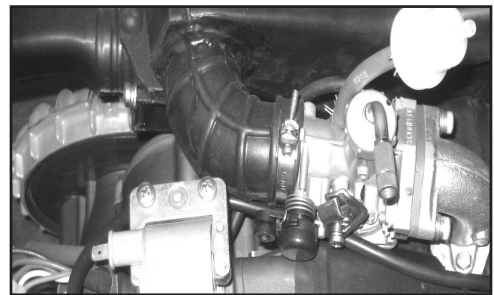

Fig. C

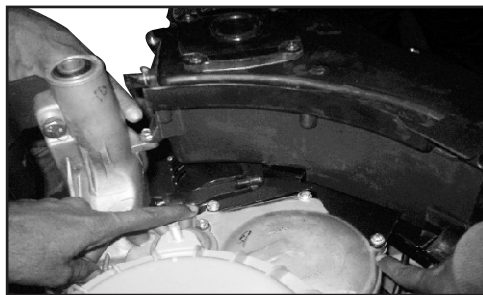

Fig. D



Fig. E

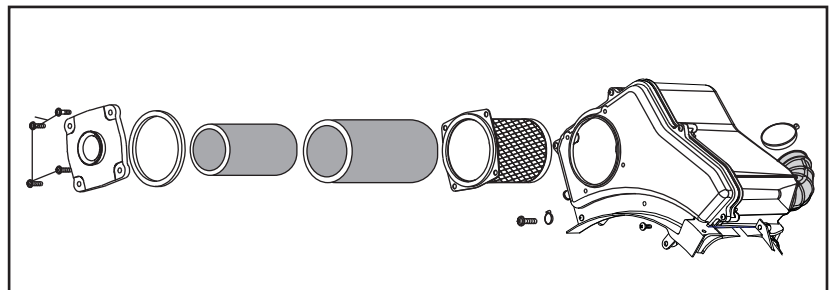

Fig. F

## CARE & MAINTENANCE

### FUEL LINE :

Remove RH side cowl.

Check the fuel line for deterioration, damage or leakage.

Replace, if necessary.

Check for leakage after installing new fuel pipe.

Fig. A.

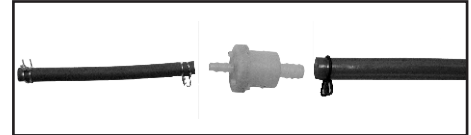

Fig. A



Fig. B

### FUEL STRAINER IN FUEL COCK AND ON LINE FILTER :

Drain out all the petrol in fuel tank.

Remove fuel tank by opening bolts.

Using special tool no. RS-00231 open fuel cock from the tank.

Fig. B and C

Check fuel screen in strainer.

Fig. D

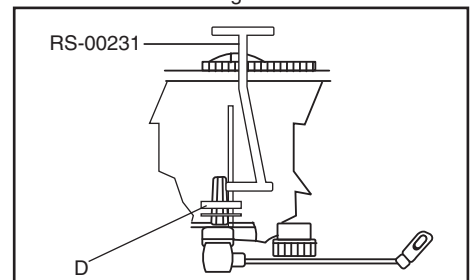

Fig. C

Clean in non-flammable or high flash point solvent.

Check for clog and damage.

Check for swelling of screen and on line fuel filter.

Replace fuel cock, if necessary.

Install strainer on fuel cock and tighten the fuel cock in fuel tank.

Check in line filter, replace if dogged / choked.

Fig. E

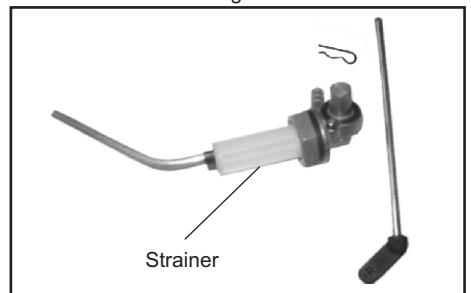

Fig. D

Fill petrol and turn ON fuel cock and check for leakage in fuel cock.

### CRANK CASE BREATHER :

This is to be serviced more frequently when used in dusty area's or in rainy season.

Open breather tube from crank case. Take out deposits and clean thoroughly.

Fig. F

Check breather tube for damages.

Replace, if required.

Install breather tube back on crank case.

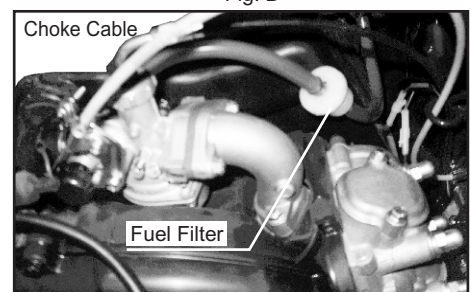

Fig. E

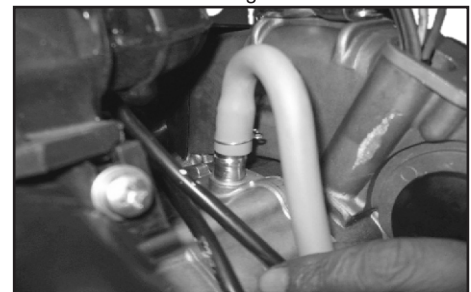

Fig. F

**VALVE CLEARANCE SETTING**

**ENGINE - COLD CONDITION**

(Below 35°C)

1. Remove IN & EX valve inspection covers.
2. Align Magneto rotar mark with mark on fan cover.
3. Check compression stroke by valves (no movement) action but both the rockers should have play. If there is no play rotate crank shaft for one more turn and align with mark, and again check, rocker arm free play.
4. Check valve clearance as below by inserting feeler gauge between valve adjusting screw and valve stem.  
Fig. B  
Inlet valve - **0.06 ± 0.01 mm** and  
Ex. valve - **0.08 ± 0.01 mm** by feeler gauge.
5. For adjustment of valve clearance loosen the valve adjusting screw lock nut and adjust the valve clearance by turning the adjusting screw until there is a slight drag on the feeler gauge. Apply engine oil to the valve adjusting nut thread. Hold the adjusting screw and tighten the lock nut.  
Fig. C
6. Finally tighten lock nut.  
Fig. D

**Special Tool**

- i) **T - 3377865** - Valve clearance adjustment

Tighten Torque - **0.9 kg-m**

- ii) Set of feeler gauge

- Tappet gap adjuster set
- Feeler gauge - **0.06 mm**
- Feeler gauge - **0.08 mm**

7. Coat a new 'O' ring with oil

Install 'O' ring into the tappet cover

Fit tappet cover with bolts

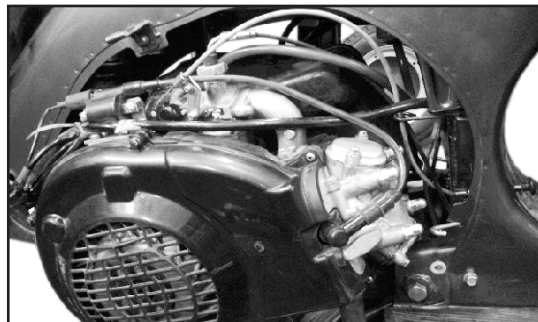

Fig. A

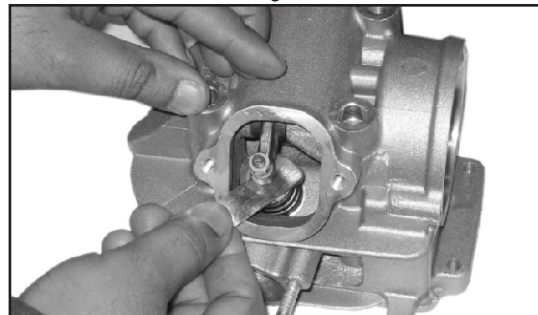

Fig. B

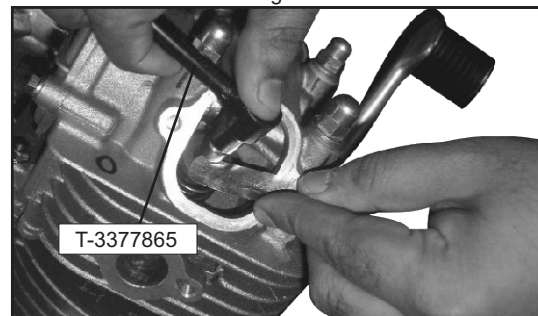

Fig. C

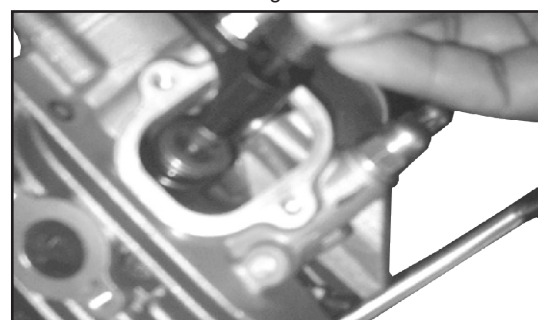

Fig. D



Fig. E

## CARE & MAINTENANCE

---

### CHOKE OPERATION

Check for smooth operation of choke knob and lubricate if required.

Check choke cable for damages, kinks and cuts.



Fig. A

### ENGINE IDLE SPEED

Inspect and adjust the idle speed after all other engine adjustments are done as per specification.

Idle speed is adjusted / checked in warm engine only.

For warming engine run it in idle speed for 3/4 minutes. and stop it for few minutes.

Keep scooter on stand at plain surface.

Check rpm with the help of tachometer.

Adjust idle rpm by throttle screw, if required.

**Idle speed 1200 ± 100 rpm.**

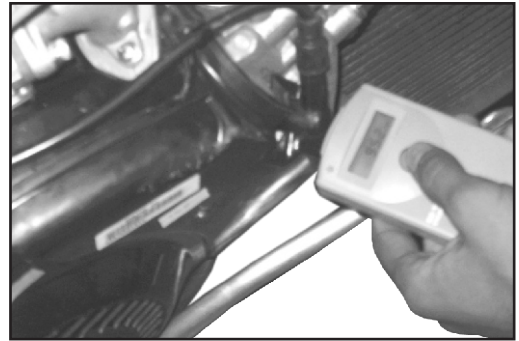

Fig. B

## ELECTRONIC IGNITION UNITS TEST

### C.D.I. (CAPACITOR DISCHARGE IGNITION)

It consists of diodes, capacitor and SCR. The current from Charging coil stored in the capacitor and discharges to the primary winding of High Tension coil through SCR on receiving the signal from Pick up.

**Test :** For testing defective CDI, connect the same in place of a C.D.I. working on a running scooter. If the scooter starts easily, the unit is good. If it does not start, the unit is defective and needs to be replaced.

### HIGH TENSION COIL :

This is a step up transformer having primary and secondary windings on a laminated core. Primary winding receives voltage from ignition capacitor of CDI and steps up on secondary winding upto 25 - 32 KV.

**Test :** For testing defective H.T. coil, connect the same in place of a H.T. coil already working on a running scooter. If the scooter starts, the unit is good. If it does not start, the unit is defective, and needs to be replaced.

### Check resistance at various points

Disconnect the wires from the ignition coil and measure the primary coil resistance.

Fig. C

### Primary coil resistance : 0.4 to 0.5

Disconnect the H.T. lead from the spark plug. Measure the secondary coil resistance.

Fig. D

**Secondary coil resistance :** (Without Suppressor cap). 3.30 to 3.5 K .

Suppressor Cap resistance :  $5K \pm 1.25 K$  .

### NOTE:

These are sealed units hence no repairs can be carried out and the unit has to be replaced, if it is not functioning.

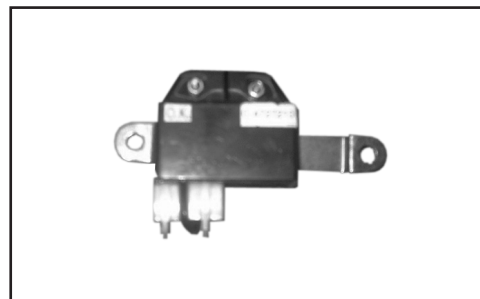

Fig. A

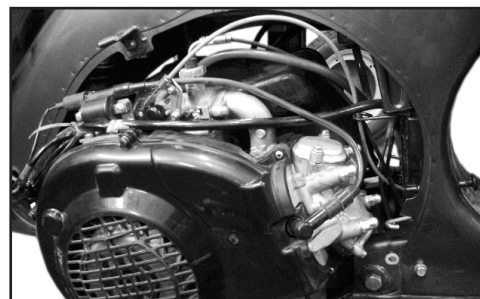

Fig. B

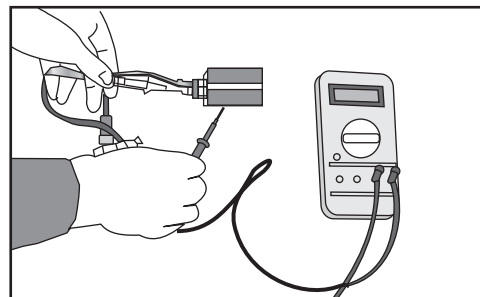

Fig. C

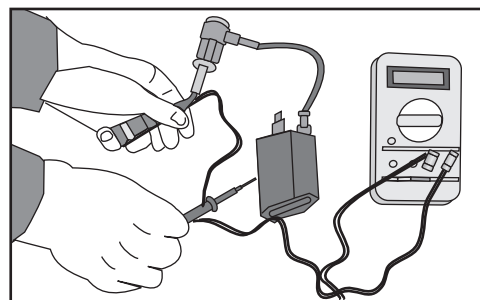

Fig. D

## CARE & MAINTENANCE

### CHARGING COIL

It is coil wound on a laminated core and generates a voltage of 200V - 300V A.C. for charging of condenser inside the CDI. The serviceability of charging coil can be checked by.

- (i) Checking the ohmic value across Green and White wire which should be  $390 \pm 20$  .

Fig. A

- (ii) Connecting a Neon bulb of 220 V (in series with resistance) across Green and White wires. Kick the scooter to rotate magneto, the neon bulb should glow simultaneously.

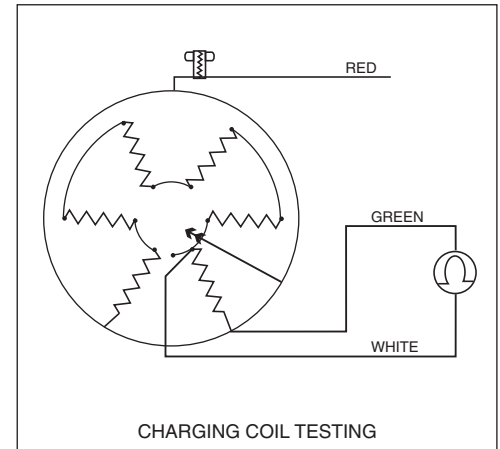

Fig. A

### PICK UP COIL

It generates a signal impulse which is directed at the gate of SCR (Silicon Controlled Rectifier) and allows the charged capacitor to discharge through SCR when signal is received. The serviceability of pickup coil can be checked by :

1. Checking the ohmic value across the Red and White wires. It should be :  $110 \pm 15$
2. Connecting L.E.D. of 1.5 volt across Red and White wires, kick over the scooter, to rotate magneto. The L.E.D. should flash simultaneously.

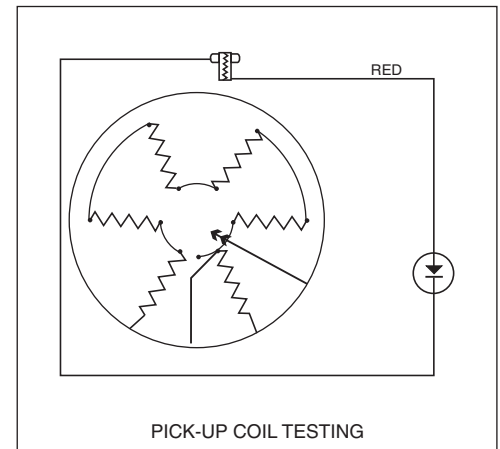

Fig. B

**ELECTRONIC LIGHTING SYSTEM**

**Testing of fly wheel magneto :**

**A.C. Section (lighting coils)**

The output voltage from magneto (lighting coils) is tested as under :

1. Connect the non-inductive resistance of 1.90 - 300W and a True RMS voltmeter as per circuit diagrams Fig. A. The regulator is disconnected (contacts 'A' 'OFF' and 'B' 'ON') the voltage across the 1.90 - 300W non-inductive resistance should measure as under :

Volts	R.P.M.
10.5 +1.5 -0.0	≈ 1500
15 +1.0 -0.5	≈ 5000

2. Disconnect the non-inductive resistance and connect regulator with the lighting coil (connect 'A' on and 'B' off).

The voltage should read as under -

Volts	RPM
10.5 ± 0.5 V	≈ 1000
14.5 ± 0.5 V	≈ 3000

**Testing of flywheel magneto (D.C. Section) :**

**Measurement of charging current :**

Connect D.C. voltmeter 'V' and D.C. Amp. meter 'A' as shown in Fig. B. Start the engine with charged battery at constant voltage between 13 - 13.5 V.

The current generated by a magneto should be :

At 2000 r.p.m.	1-1.2 Amp.
At 5000 r.p.m.	2.0-2.2 Amp.*

(\*Depending on the condition of the battery)

**Measurement of regulated Voltage :**

Connect D.C. voltmeter 'V' and D.C Amp. meter 'A' with a fully charged battery. At on load the voltage should be 14-14.3 V at 5000 r.p.m.

Fig. B

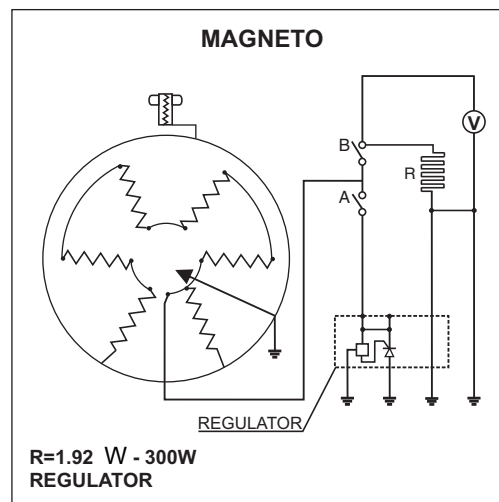

Fig. A

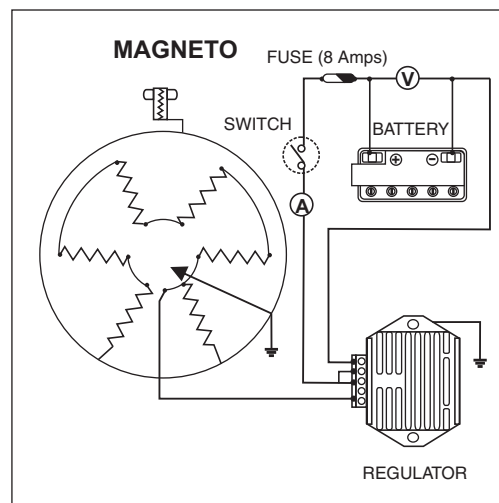

Fig. B

**NOTE :**

- The specification of voltmeter and Amp. meter are:
- D.C. Amp. meter (min. full scale deflection 5 Amp.)
- D.C. Voltmeter (min. full scale deflection 20 volt class 1)

## CARE & MAINTENANCE

---

### Testing of voltage regulator (A.C. Section) :

Check the regulator by connecting the same in a scooter whose electrical system is performing satisfactorily.

Following equipment is required for the test :

1. Voltmeter for measuring A.C. voltages at effective value (R.M.S.) with 25-30 volts.
2. 1.92 - 300 W approx. non-inductive resistance.
2. Tachometer.

### Testing procedure :

- (a) Remove regulator by replacing it with the one to be tested.

**Do not connect the terminal which joins GREY wire to avoid burning of bulbs if regulator is defective.**

- (b) Connect voltmeter 'A' across ground and other terminal end to regulator terminal where gray wire was connected and let the engine run at 5000 (approx.) r.p.m. If voltage reading is between 12.5 to 15 volt (true r.m.s) the regulator is in perfect condition.

### Test results :

1. Lower voltage than the specified range indicates that the regulator is defective (internal short circuit).
2. Higher voltage than the higher voltage range indicates that the regulator does not stabilize voltage. This is the cause of burning out of bulbs.

In both cases the defective regulator has to be replaced with a new regulator.

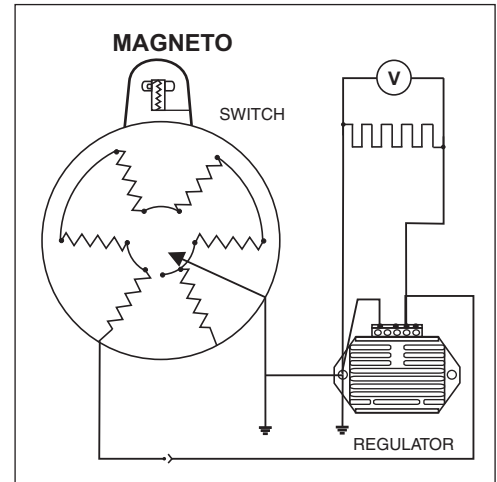

Fig. A



**Flasher unit (Thermal cut out) : AC Simultaneous Blinking.**

This is an electronic flasher which provides intermittent AC voltage to turn signal lamp (TSL) switches about  $80 \pm 2$  times/min. and provides signal to the front and rear TSL bulbs. Front and rear bulbs glow simultaneously in this flasher unit. This is a sealed unit hence can not be serviced. In case of failure replace it. To check the unit connect 12 volt AC supply. It should flash.

Fig. A

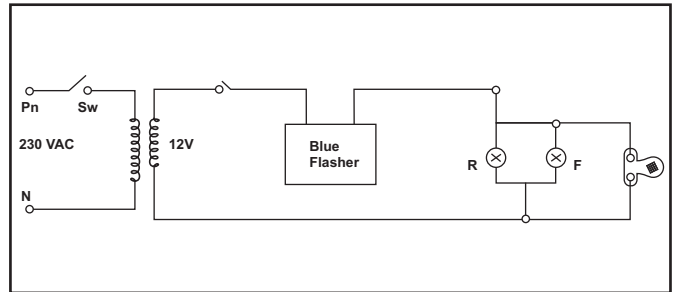

Fig. A

**Flasher unit (thermal cut out) : AC Alternate Blinking**

This is an electronic flasher which provides intermittent AC voltage to turn signal, with a difference that front and rear TSL bulbs glow alternatively. Circuit is different. This is a sealed unit hence can not be serviced. In case of failure replace it. To check the unit connect 12 volt AC supply. It should flash.

Fig. B

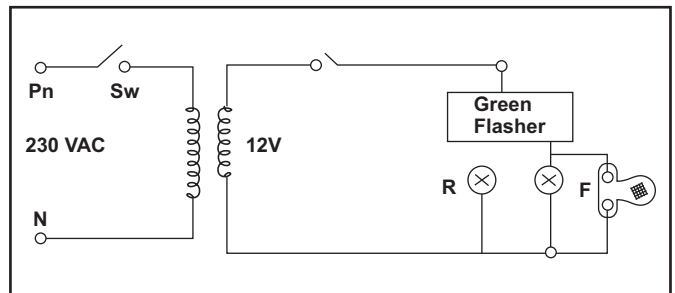

Fig. B

**Flasher unit (thermal cut out) : DC Alternate Blinking.**

This electronic flasher is also designed for alternate blinking of front and rear TSL bulbs. This is a sealed unit hence can not be serviced. In case of failure, replace it. To check the unit connect 12 volt DC supply. It should flash.

Fig. C

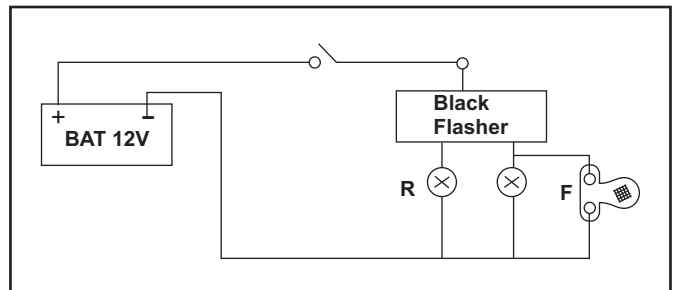

Fig. C

## CARE & MAINTENANCE

### ELECTRICAL SUB-ASSEMBLIES

#### Horn (On Battery)

This unit functions on 12 volt DC supply from Adopter unit to horn switch then from horn switch to horn.

**Check :** Connect the input of 12 volt DC supply to horn. The horn should blow at its normal level of sound. In case of failure try to adjust the horn or replace with a new horn.

#### Fuel Gauge

- (a) The fuel gauge is comprised of two separate units:
  - (1) Fuel Gauge unit located in the speedometer.
  - (2) Float Unit; located under seat and inside the fuel tank.
- (b) The gauge unit has two winding 'A' & 'B' placed at 90° from each other and are connected to regulator through rectifier. One end of windings 'A' is connected to ground; and the other with winding 'B' in series which leads upto resistance 'R' of the float unit. The reading on gauge unit scale depends on the current flowing through coil 'B' or the resistance in circuit. The resistance 'R' varies and depends on the quantity of fuel in the tank, which is controlled by float unit.

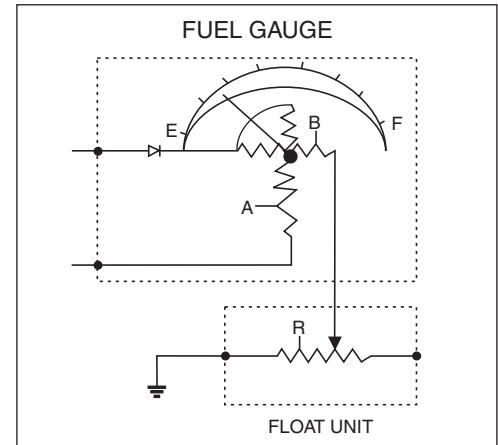

Fig. A

#### Testing

##### Gauge unit

- (a) Connect the unit across the 6 volt A.C. supply (grey and black wire).
- (b) The gauge shows 'E' (Empty).
- (c) Connect the third wire (white wire) to earth (black wire), and If the unit shows 'F' (Full), then it is in order.

##### Float unit :

- (a) Remove the unit from the fuel tank and move the float up and down slowly.
- (b) The fuel gauge needle should move freely.
- (c) If not, remove the white wire from float unit and connect it to ground.
- (d) The fuel gauge should show full. This confirms that the float unit is not in order hence needs replacement with a new one.
- (e) Preferably the total resistance of float unit should be measured with a multimeter which should be  $110 \pm 10$  Ohm.

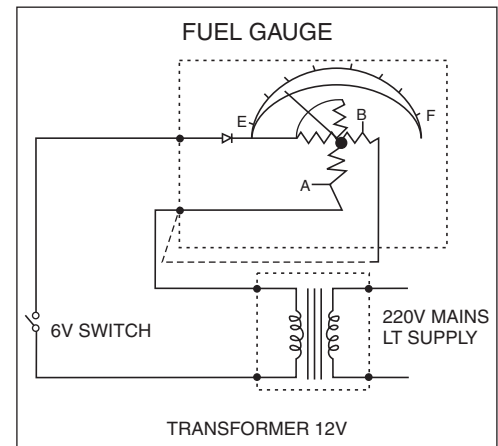

Fig. B

**INSTRUMENT PANEL**

The Instrument panel contains the following :

1. Fuel Level Indicator Needle.
2. Head Light High Beam Indicator
3. LH Turn Signal 'ON' Indicator
4. Speed Indicator Needle
5. Odometer
6. RH Turn Signal 'ON' Indicator
7. Headlight Low Beam Indicator
8. Fuel gauge

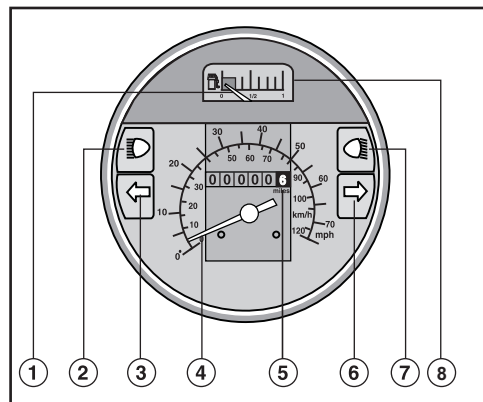

Fig. A

**SELF STARTER (Electric start) SYSTEM**

Main components in circuit :

1. Battery 12V 9Ah
2. Fuse 8 Amp.
3. Regulator cum charger
4. P.R.D.
5. Declutch switch
6. Push switch
7. Ignition switch (AC/DC type)
8. Cut-out relay
9. Starter motor

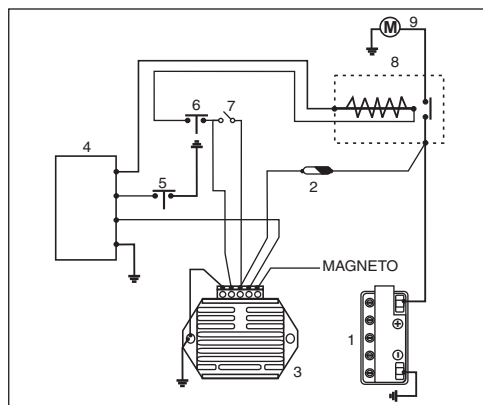

Fig. B

## CARE & MAINTENANCE

### P.R.D. (Preventive Restart Device):

This is an electronic cut off switch, which connects the circuit of cut-out relay while starting and cuts off after starting the engine. Thus engine can't be cranked in the running condition. It guards the teeth of starter motor and flywheel (Carona gear) from damage. This is fitted under steering col. cover at bottom side.

Fig. A

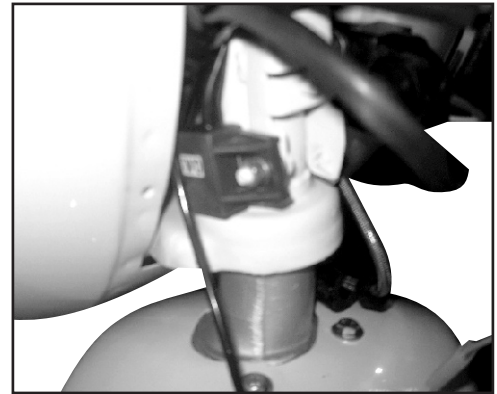

Fig. A

The P.R.D. relay can be checked as follows :

- (a) Connect the P.R.D., bulb (12V-10W), battery (12V), push switch, ON/OFF switch and 12 volt A.C. supply.

Fig. B

- (b) Switch 'OFF' the ON/OFF switch and press the push switch. The bulb should glow then release the push button bulb will be off.
- (c) Switch 'ON' the ON/OFF switch and again press the push switch. The bulb should not glow.

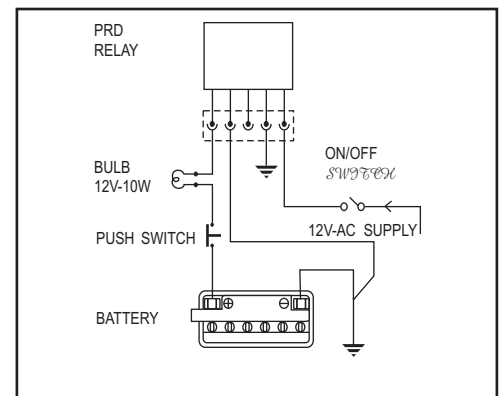

Fig. B

### Cut-out relay :

- (a) Connect the cut-out relay and press the button.

Fig. C

- (b) Relay should operate with click noise and light should glow.
- (c) If no noise is observed the relay is in open circuited and the lamp will not glow.
- (d) If it fails to crank starter even after clicking and no glow of lamp, the contacts are dirty/pitted. Clean with fine emery paper and refit.

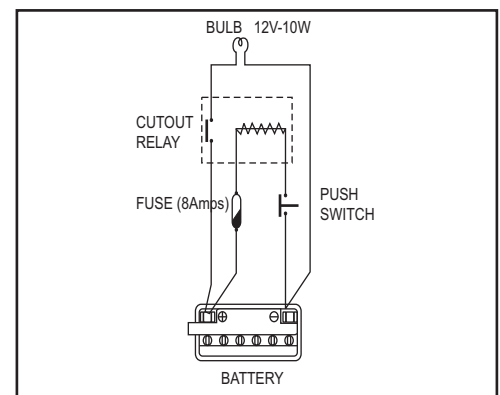

Fig. C

**STARTER MOTOR**

**Main features :**

Rated voltage	12 V
Rated output	0.48 KW
Direction of Rotation	Left hand (clock wise)
Type of motor	DC series motor
Meshing	By pinion and crown gear on fly wheel
No load current	30 Amp.
On load current	80 to 100 Amp.
Jammed starter	200 Amp.

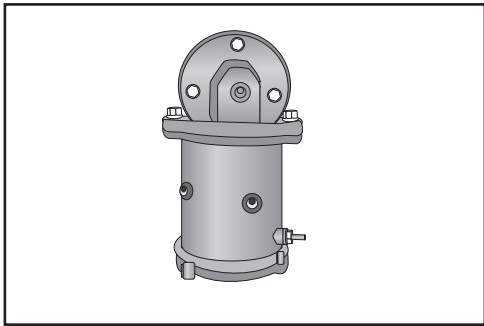

Fig. A

**Removal & re-fitting of starter motor :**

- (a) Remove the RH cowl and rear wheel.
- (b) Remove the rear shock absorber bottom mounting bolt and take the shock absorber away from crank case shocker mounting.
- (c) Remove fan cover by unscrewing the four screws.

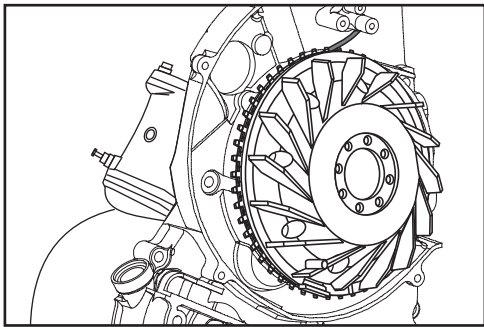

Fig. B

- (d) Pull back the insulating cap and remove the nut and washer from the starter motor lead terminal.
- (e) Disconnect the blue lead from the terminal. Remove the three nuts 'A' holding the motor 'B' and take out washers.

Fig. C

- (g) Remove the motor from the engine.
- (h) Follow the reverse procedure for re-fitting.

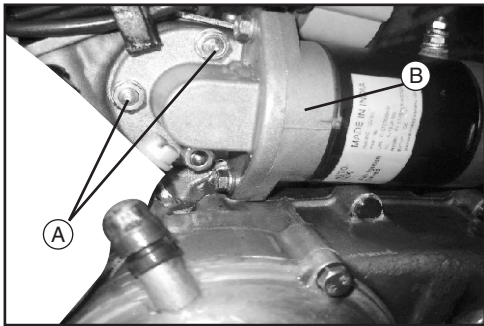
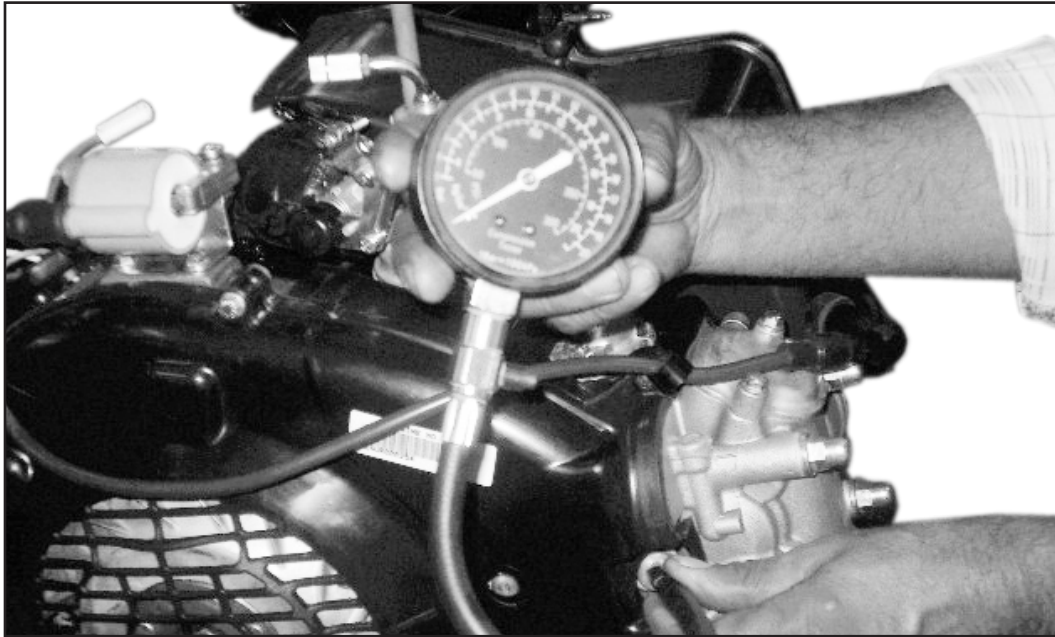

Fig. C

### ENGINE COMPRESSION TEST



#### TESTING PROCEDURE

##### STEP - I

1. Warmup engine to normal running temperature (hot condition).
2. Remove spark plug & connect compression gauge. **X-4576002**
3. Ensure that
  - (a) Fuel cock is in "off" condition
  - (b) Ignition switch is in "OFF" position.
  - (c) Choke is in "OFF" position (normal running condition).
4. Accelerate throttle to "FULL" condition & then kick several times (6 to 8 times).
5. Note down the reading and repeat the above process 3 times. Take average reading to know actual compression pressure. Specified engine compression pressure is  $10 \pm 2$  Kg/cm<sup>2</sup>.

##### STEP - II

Incase compression pressure is less than 8 Kg/cm<sup>2</sup>, then refit spark plug & start again to warmup the engine.

- a. Remove spark plug & put few drops of engine oil inside the combustion chamber.

- b. Connect compression gauge & repeat above said procedure as explained in step-I.

- **If compression pressure reading increases, then check for**

- worn out cylinder
- worn out piston/rings
- scoring / seizure of cylinder / piston
- piston ring jamed in groove

- **If compression pressure does not increase, then check for**

- incorrect tappet gap adjustment
- improper torque of cylinder head cap nuts
- valve seat damage/leakage
- valve bend
- cylinder head warpage
- improper valve timing
- blownout cylinder head gasket

##### STEP - III

Incase compression pressure is more than 12 Kg/cm<sup>2</sup>. Then engine requires Decarbonisation of cylinder head / piston (combustion chamber).

### SPARK PLUG

Open RH side cowl.

Take out suppressor cap.

Clean the area around the base of spark plug with compressed air, so that no dust / dirt or foreign particle, goes inside the engine while opening spark plug.

Open spark plug and cover the hole by cloth.

Inspect spark plug

- Insulator for breakage/crack.
- Wear of electrodes.

Colour and burning condition

- Brownish grey colour and no erosion of electrodes indicates good condition.
- Dull black velvety carbon deposit indicates rich mixture.
- Burnt white insulator with mettalic bead deposits indicates over heating / malfunctioning of ignition system / lean mixture.

Clean the spark plug with wire brush or on spark plug cleaning machine.

Replace spark plug every 10000 kms.

#### NOTE :

Always use specified spark plug on scooter. Specified spark plugs are given at 'Technical Specification'.

Measure the spark plug gap between side and central electrodes by feeler gauge. If necessary adjust it to specified gap.

**SPARK PLUG GAP – 0.7 to 0.8 mm.**

Fit spark plug alongwith washer in the cylinder head first by hand and then torque to specified torque.

**TIGHTENING TORQUE – 1.1 kg-m.**

#### NOTE :

Do not over tighten the spark plug

While fitting new spark plug ensure that sealing washer contacts the seat properly.

Connect spark plug cap.

Fit RH cowl.

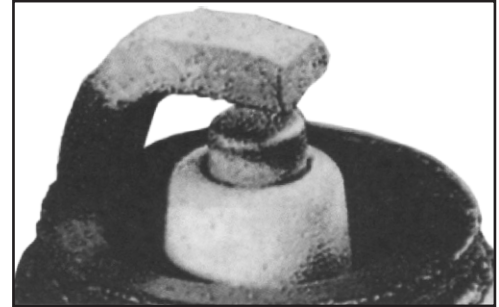

Fig. A



Fig. B

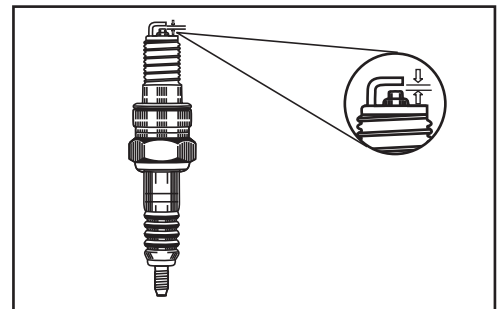

Fig. C



Fig. D

---

# LUBRICATION SYSTEM

## INDEX

	<b>PAGE No.</b>
GENERAL SERVICE DETAILS	43
SPECIFICATION	43
FLOW CIRCUIT DIAGRAM OF ENGINE OIL	44
LUBRICATION CIRCUIT	45
RECOMMENDED OILS AND LUBRICANTS	46
CHANGING OIL IN ENGINE	46
PAPER FILTER ELEMENT	47
OIL PUMP	47
ENGINE OIL FILTER SCREEN	49
LUBRICATING POINTS.	50

### GENERAL SERVICE DETAILS

Whenever required the oil pump can be serviced with the engine installed in the frame.

The engine oil should be drained out, before the starting of service procedure.

Care to be taken for not allowing dust and dirt to enter in the engine, while removing and installing the oil pump.

Oil pump must be replaced as an assembly, if any portion is worn out, beyond the service limits.

After the installation of oil pump in engine, oil pressure and leakage must be checked.

### SPECIFICATIONS

CRITERIA		SPECIFICATION
Recommended engine oil		20W40 of any reputed company
Engine oil capacity		850 ml.
Oil pump type		Trochoid
Oil pump	Outer rotor to body clearance	0.35 mm
	Rotor tip clearance	0.20 mm
	Pump end clearance	0.12 mm

### TORQUE VALUE

Oil pump screws

Tightening Torque - **1.1 kg-m.**



FLOW CIRCUIT DIAGRAM OF ENGINE OIL

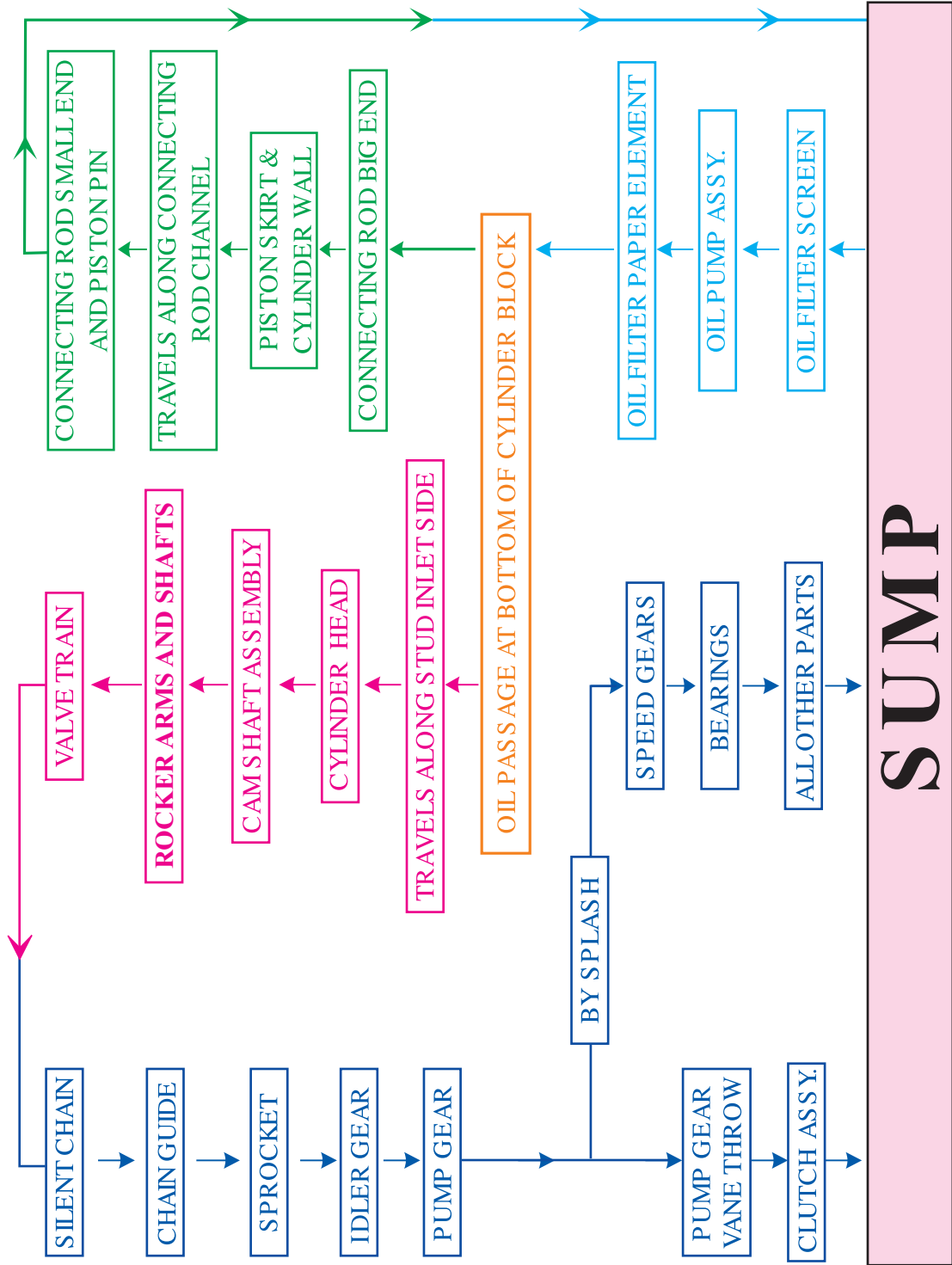

### LUBRICATION CIRCUIT

- Oil is filled from level gauge (dipstick) hole in magneto side crankcase.
- Through a cut, oil moves to strainer, housed in the magneto side crankcase, where it is filtered.
- Filtered oil comes through a passage at bottom of oil pump in clutch side of crankcase.
- Pump sucks this oil and then with requisite pressure development, sends it, to paper element filter, housed in clutch cover. This oil, after filtering passes from clutch cover, comes back to crankcase and goes up to cylinder block bottom surface plane.
- Through a passage in cylinder block, it is distributed into two routes.
- First going along with spark plug side cylinder stud, reaches up to a space at the back side of cam shaft. Here it lubricates cam shaft lobes and by splash lubricates inlet and exhaust valve trains and bearings. A passage is made in cylinder head for drainage of oil. Engine oil comes through this passage and falls down, lubricating silent chain, tensioner, idle gear and clutch.
- Pump gear is provided with special vane in outer body for, clutch lubrication.
- From second route it passes through crank shaft bearings lubricating it and, by connecting-rod channel it moves up and reaches up to its small end, lubricating cylinder block walls and then scraped down by scrapper rings of piston.

## LUBRICATION SYSTEM

### RECOMMENDED OILS AND LUBRICANTS

S.No	DESCRIPTION OF PARTS	APPLICABLE LUBRICANTS	RECOMMENDED BRAND OF LUBRICANTS
1.	Clutch lever	Grease	Automotive / Bearing Grease
2.	Steering Column Bearing	"	"
3.	Front Wheel Bearings	"	"
4.	Speedo Drive Gear	"	"
5.	Front Suspension	"	"
6.	Control Cables	"	"
7.	Gear Control assy.	"	"
8.	Engine Oil	Oil	20W40 of any reputed manufacturer

- Recommended quantity of oil to be filled in engine oil is 850 ml + 0 ml.  
- 5 ml.
- Engine oil is to be replaced in new engine after running of first 750 kms.
- Thereafter it should be replaced after every run of 3000 kms.

#### NOTE :

Lower level of oil may result in failure of engine.

#### CHANGING OIL IN ENGINE

Drain off the oil in crank case by unscrewing the drain plug '2'.

Introduce a small quantity of flushing oil from filling hole and run the engine for few minutes and drain off again.

Refill engine with 850 ml. of new engine oil check with dipstick as explained on Page 26.

The operation of changing oil should be carried out in warm condition of engine.

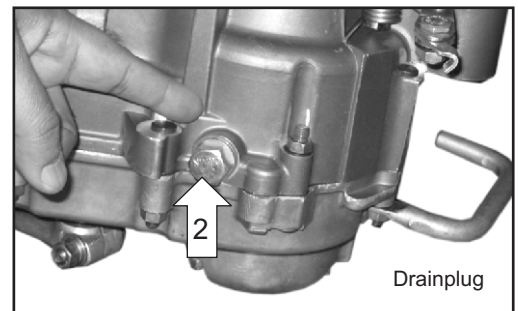

Fig. A

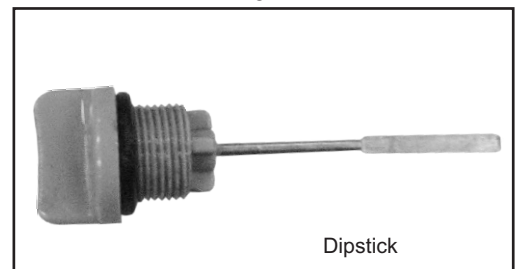

Fig. B

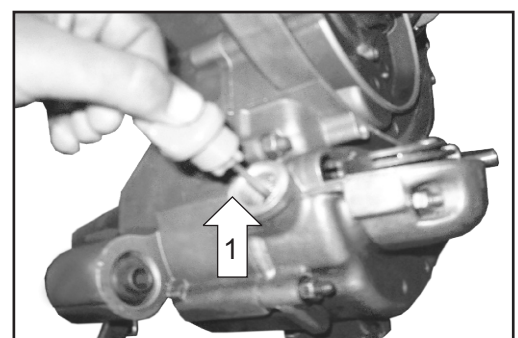

Fig. C

### PAPER FILTER ELEMENT REPLACEMENT

Open LH side cowl and spare wheel.

Open cover oil filter by opening 4 nuts, from filter cover, and take out paper element and its gasket.

Fig. A.

Clean the element housing properly, and fit spring first at the base.

Replace it with new paper filter element and gasket set. Paper element along with its gasket should be replaced after every 3000 kms, run of vehicle. In case vehicle is used in dusty atmosphere, it is to be replaced at every 2000 kms.

For installation of filter, cavity provided in it should fixed over the spring.

Fig. B.

#### NOTE :

Installation of filter element in reverse direction may damage engine

### OIL PUMP

#### CARE

When servicing oil pump take care, that during servicing, dust or dirt does not enter the engine.

#### REMOVAL

Remove LH side cowl spare wheel and rear wheel.

Drain the engine oil.

Open the clutch cover and cable.

Open oil pump gear circlip and take out gear with roller and washers carefully.

Remove three oil pump mounting screws and take out oil pump assembly.

#### INSPECTION :

Check the pump rotor and housing for wear.

Outer rotor to body clearance

Service limit - **0.35 mm**

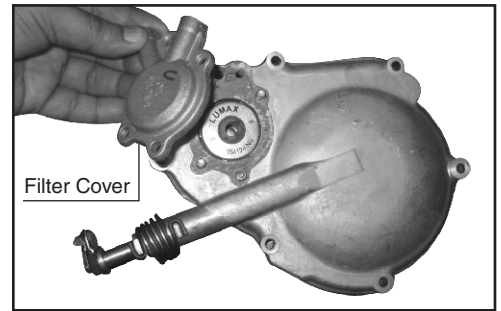

Fig. A

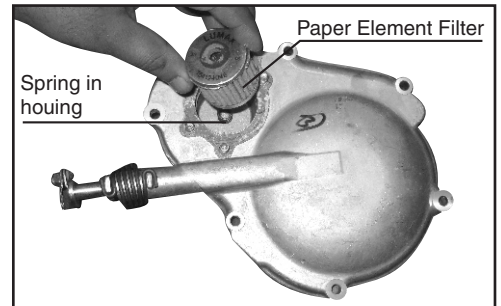

Fig. B

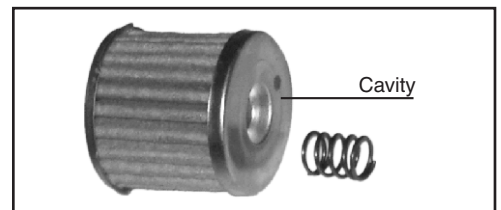

Fig. C

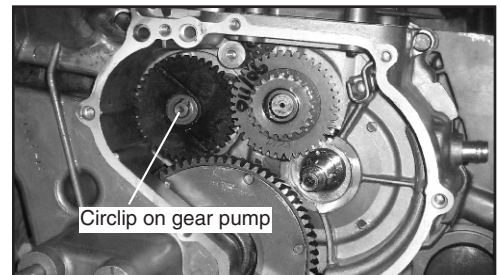

Fig. D

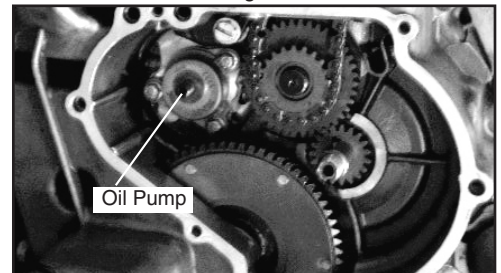

Fig. E



Fig. F

## LUBRICATION SYSTEM

---

Check rotor tip clearance

Service limit - 0.20 mm

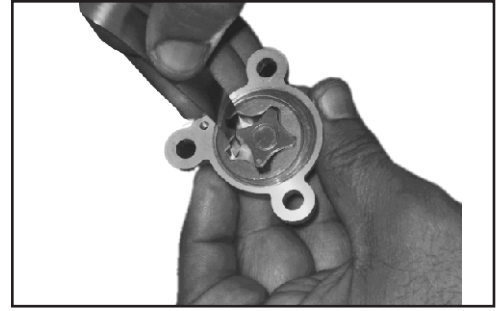

Fig. A

Check pump end clearance

Service limit - 0.12 mm



Fig. B

### INSTALLATION :

Clean all parts by solvent and dry them, by blown air.

Fill engine oil in housing for pump and lubricate pump.

Assemble in reverse order of disassembly.

Fill engine oil at correct level. Page 26.

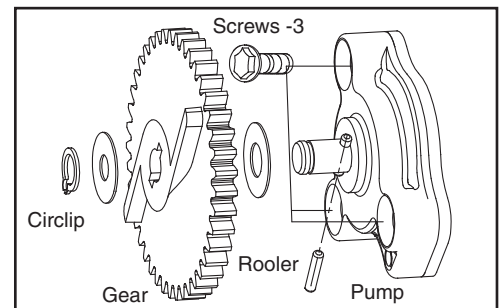

Fig. C

**ENGINE OIL FILTER SCREEN CLEANING**

Drain out engine oil by opening drain plug.

Open hex head cover of strainer from fly wheel side crank case and take out filter screen & spring

Fig. A.

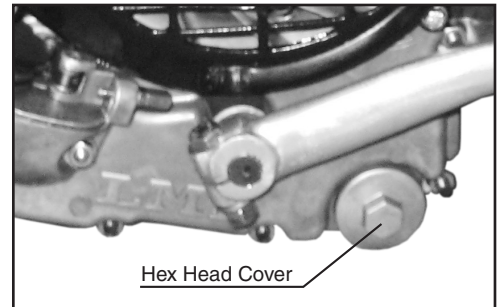

Fig. A

Clean oil filter screen and cover by solvent and air dry it.

Check for deterioration of screen and cover nut and replace 'O' ring.

Fig. B

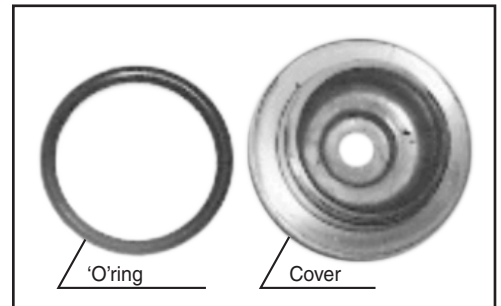

Fig. B

During installation be careful to fit gasket side of screen towards crank case and dome shaped screen towards outside.

Fig. C

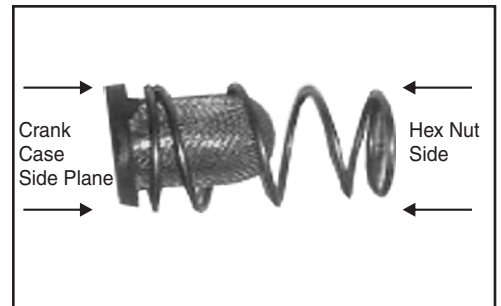

Fig. C

Tightened hex head cover nut.

Fig. D

Tightening torque - **1.5 kg-m.**

Refill 850 ml. of engine oil 20W40 and check level with dipstick.

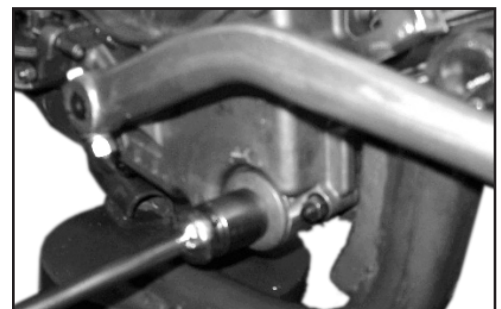

Fig. D

# LUBRICATION SYSTEM

## LUBRICATION POINTS



CLUTCH LEVER

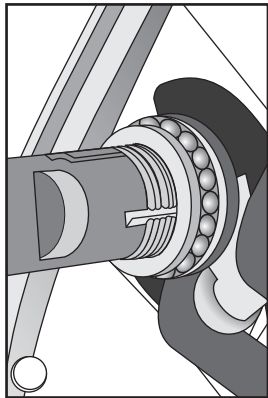

STEERING COLUMN

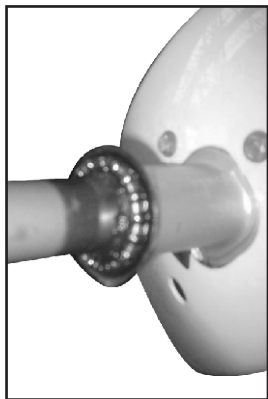

BALL CAGE

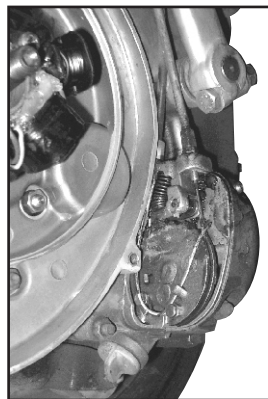

GEAR CONTROL CABLE



SPEEDO GEAR

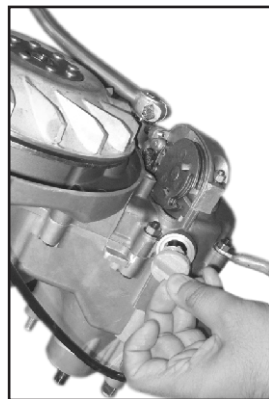

ENGINE OIL

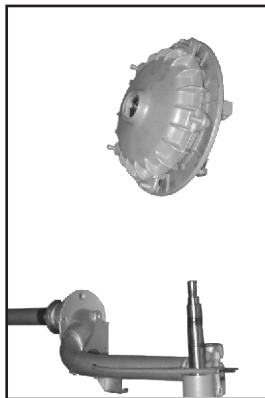

FRONT SUSPENSION

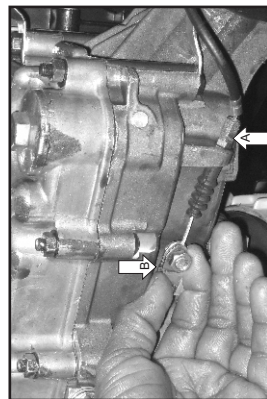

REAR BRAKE CABLE



CENTRAL STAND



BRAKE PEDAL



FRONT BRAKE JAW PLATE

### LUBRICATION

#### **Gear control bracket assy.:**

Remove gear control bracket assy. cover. Wash the assy gently with solvent. Pressure wash and blow dry it with compressed air. Apply recommended grease and refit cover.

#### **Front wheel bearing and Speedo drive gear :**

Remove front wheel with drum. Apply recommended grease on front wheel bearings and speedo drive gear. Refit front wheel.

#### **Front brake jaw plate assy. :**

Remove circlip lock. Unscrew bolts of shock absorber and take out front brake jaw plate. Clean the bearings and shaft, then apply grease as recommended. Lubricate brake shoe pins and cam for brake. Refit the front brake jaw plate in its place and put back the circlip.

#### **Rear brake pedal and central stand :**

Clean rear brake pedal link area and central stand hinge brackets with solvent and pressure wash. Blow dry with compressed air. Lubricate brake pedal pin and central stand brackets for smooth operations.

#### **Brake and clutch lever :**

Lubricate the levers and bracket housings in respective movement area by recommended grease.

#### **Care of vehicle when not in use for long period :**

If scooter is not going to be used for more than two months then, it should be stored properly as per the following guidelines.

With the help of a pipe siphon out the petrol from the fuel tank.

Start the engine for some time and exhaust the petrol in the carburettor.

Remove the spark plug and put few drops of engine oil in the spark plug hole. Press the kick lever a couple of times. Re-fit the spark plug. Clean the vehicle thoroughly and apply antirust grease on all unpainted metallic parts.

For autostart models remove the battery. Raise the wheel off the ground by placing wooden planks and deflate the tyres so that they do not touch the floor. Cover the scooter.



---

# FUEL SYSTEM

## INDEX

	PAGE No.
GENERAL SERVICE DETAILS	53
SPECIFICATION	53
AIR FUEL FLOW CHART	54
CARBURETTOR REMOVAL / INSTALLATION	55

## GENERAL SERVICE DETAILS

Gasoline is highly flammable and explosive under certain conditions, therefore should always be kept at a distance from working area.

Always run engine in an open, well-ventilated area. Never run engine in an enclosed space, as the engine exhaust is composed of carbon mono-oxide, which is highly poisonous and may cause unconsciousness or even death under certain conditions if inhaled in large amount.

Mishandling of control cables, by twisting or bending may cause improper running of vehicle, which may result in loss of control also.

Area where gasoline is stored would be kept apart from smoke, spark and flame.

Syphon out the petrol from the fuel tank with the help of pipe, if the vehicle is to be stored for more than one month.

Before removing carburettor, drain the fuel from carburettor float chamber in a separate pan by loosening drain screw. 'O' rings should be placed on the specified locations, while reassembly. Their locations to be noted during disassembly.

## SPECIFICATION

CRITERIA	SPECIFICATION
Model	KEIHIN PB 18-side draft
Venturi dia	18 mm.
Main jet	90
Slow jet	40
Float level height	10.0 ± 1.5 mm.
Air screw setting	1.5 to 2.5 turns
Needle clip location	In 3rd groove
Idle speed	1200 ± 100 rpm

# FUEL SYSTEM

## AIR FUEL FLOW CIRCUIT

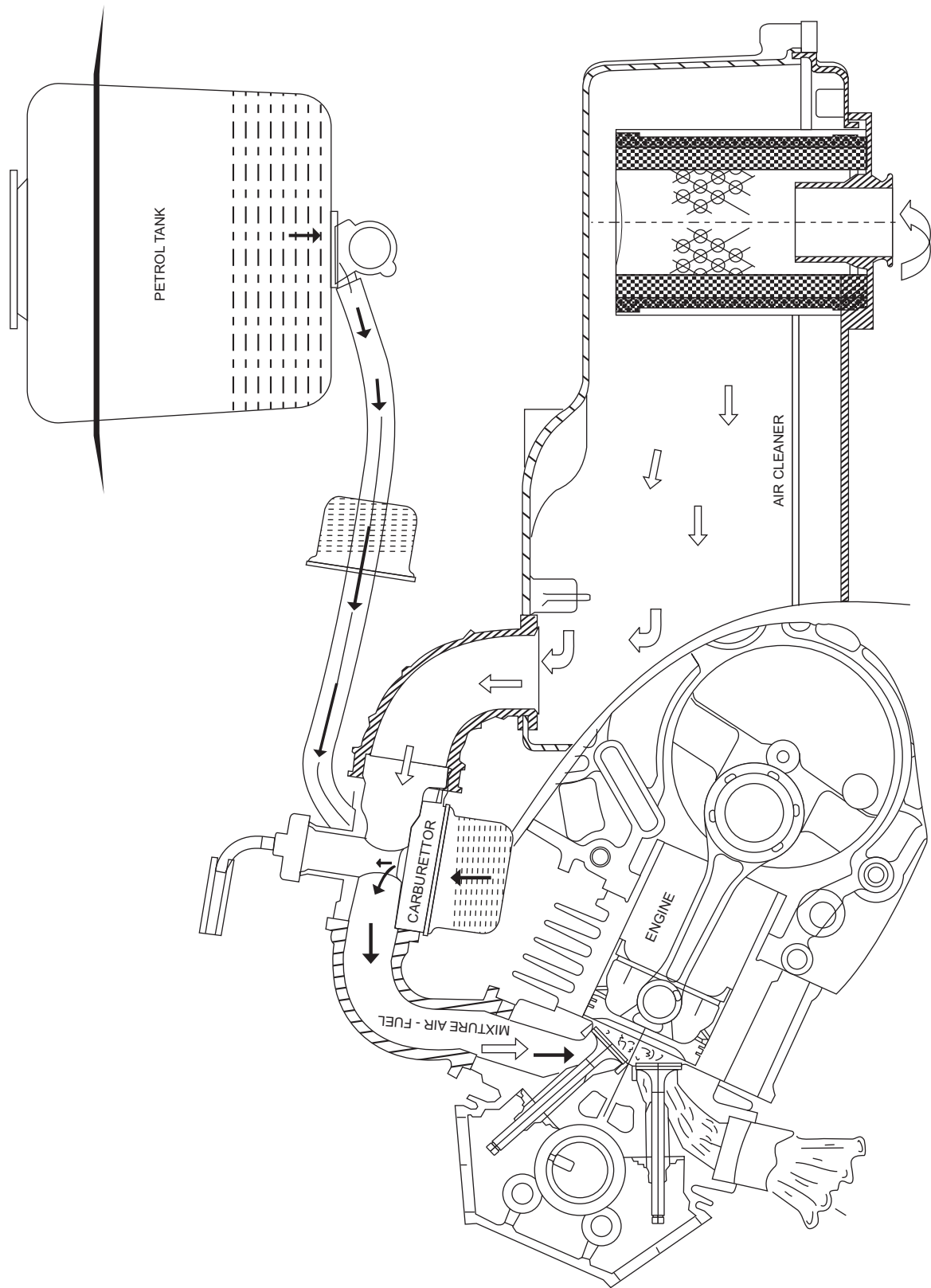

## CARBURETTOR REMOVAL/INSTALLATION

### REMOVAL

Turn the fuel cock to the "OFF" position.  
Fig. A



Fig. A

Disconnect fuel pipe from carburettor by pressing clip.

Disconnect Air vent pipe from carburettor.  
Fig. B

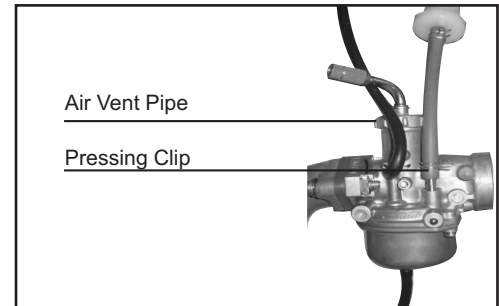

Fig. B

Loosen the clamp (band) over air cleaner connection tube (Air duct)  
Fig. C.

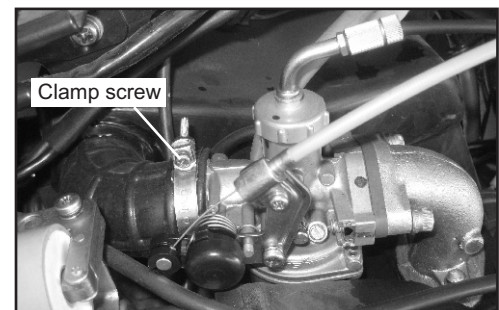

Fig. C

Drain the fuel from carburettor float chamber in a separate pan by loosening drain screw.  
Fig. D

Disconnect drain pipe from float chamber of carburettor  
Fig. D

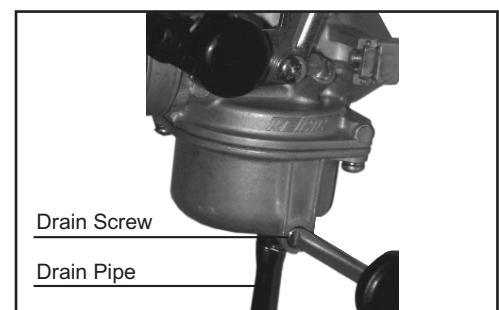

Fig. D

Remove spark plug wire (HT lead) alongwith suppressor cap from the spark plug.  
Fig. E

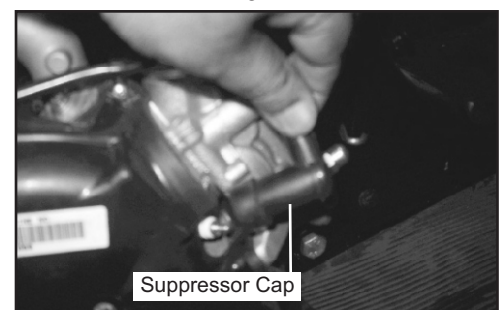

Fig. E

## FUEL SYSTEM

Disconnect the choke cable from choke actuating lever.  
Fig. A

Remove socket head bolt (2 Nos.) and pull out the carburettor assy., alongwith insulator from inlet manifold and 'O' ring.  
Fig. A

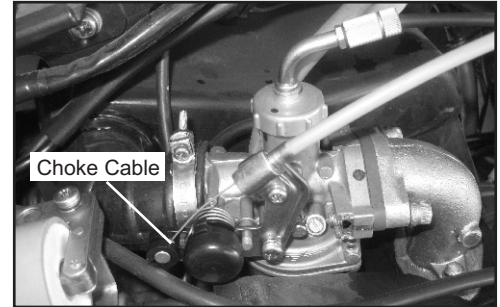

Fig. A

Open the carburettor top cap, pull out the throttle valve alongwith jet needle, clip, spring & throttle cable.  
Fig. B

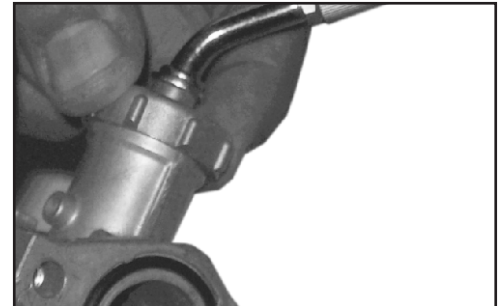

Fig. B

Remove the throttle valve from the accelerator cable by compressing the spring up and releasing cable end from the seat in long slit. Slip the tip of the cable from the slit in the valve.  
Fig. C

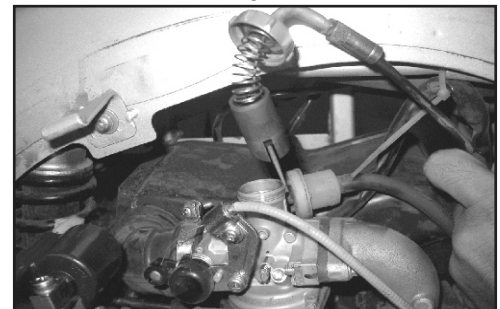

Fig. C

### INSPECTION

Check insulator for damages and replace, if required.  
Fig. D.

Replace 'O' ring in insulator side.

Check for throttle and jet needle for damage and free movement of throttle slide into carburettor bore.

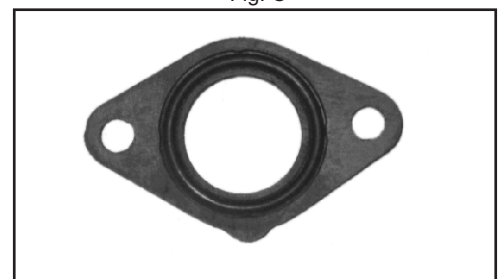

Fig. D

### INSTALLATION

Follow the reverse order of removal.

### NOTE :

Ensure that during installation of carburettor top cover along with throttle valve, full cut slit is matching with guide location, while fixing it inside the carburettor body. Throttle valve seating is proper and jet needle does not get bent.

After installation check for any fuel leakage from the carburettor or fuel line, from fuel tank to carburettor, and change if required.

Check for smooth movement of throttle valve. Adjust throttle grip free play 2 to 4 mm. (radially), by adjusting throttle adjusting screw at carburettor cap assembly.



Fig. E

**CARBURETTOR ASSY.**

Remove carburettor assy. from the engine.

**DISMANTLING PROCEDURE**

Open the carburettor top cap and take out spring.

Fig. A

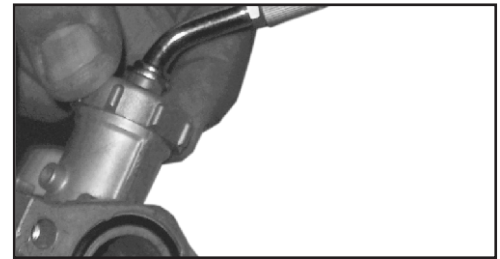

Fig. A

Remove the jet needle from the throttle valve along with clip and plate. Check for smooth finish and keep it carefully.

Fig. B



Fig. B

Remove the air screw with spring and 'O' ring and check for damage.

Remove the idle (stop) screw with spring. Check for damages, if any.

Fig. C

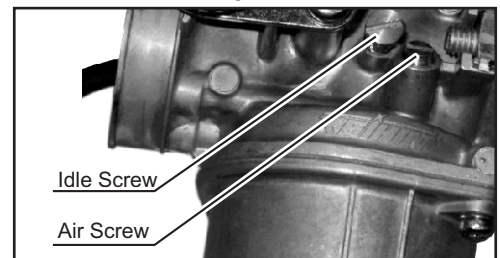

Fig. C

Remove the float chamber by unscrewing two screws.

Fig. D



Fig. D

Pull out the float arm pin to remove the float and float pin. Replace float pin, if worn out.

Fig. E

Remove the main jet along with jet holder by spanner. Then remove needle jet by pushing if necessary.

Remove the slow jet.

Fig. F

Now clean all the carburettor components and apply compressed dry air in all passages (galleries).

Check all parts for wear and damage and replace, if required.

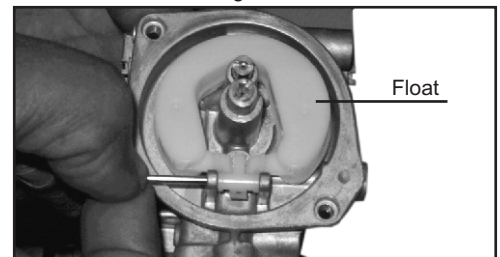

Fig. E

**NOTE :**

Don't remove clip from the jet needle groove. (in 3rd groove).  
Ensure that float and float pin is removed before carrying out any other jobs on carburettor, So that these components do not get damaged.



Fig. F

# FUEL SYSTEM

## DISMANTLING OF CARBURETTOR

### PART IDENTIFICATION

1.	Carburettor assy. PB18 KEIHIN
2.	Cable adjuster
3.	Top cover comp.
4.	Gasket, top
5.	Spring throttle valve
6.	Needle clip plate
7.	Clip
8.	Jet needle
9.	Throttle valve
10.	'O' ring, Insulator side
11.	Needle jet
12.	Holder needle jet
13.	Main jet 90
14.	Slow jet pilot (40)
15.	Float arm pin
16.	Float comp
17.	Valve comp, float
18.	'O' ring
19.	Washer Plain
20.	Spring Idle mixture adj.
21.	Adjust screw idle mixture (12 degree)
22.	Gasket float chamber
23.	Screw washer M4 x 14
24.	Clip for drain tube
25.	'O' ring
26.	Drain Screw
27.	Stop Screw (Idle screw)
28.	Spring stop screw (idle screw)
29.	Intake manifold
30.	Packing insulator carburettor side
31.	'O' ring insulator dia 25.5 x 2.4
32.	Bolt flange SH M6 x 32
33.	Gasket insulator
34.	Packing insulator carburettor
35.	Plain washer
36.	Socket head screw M6x35
37.	Spring washer

### SPECIFICATION

Model	-	<b>PB-18 KEIHIN</b>
Venturing dia	-	<b>18 mm</b>
Main Jet Size	-	<b>90</b>
Slow Jet Size	-	<b>40</b>
Needle clip location	-	<b>in 3rd groove</b>
Air Screw setting	-	<b>1.5 to 2.5 turns</b>
Float level height	-	<b>10.0 ± 0.5 mm</b>

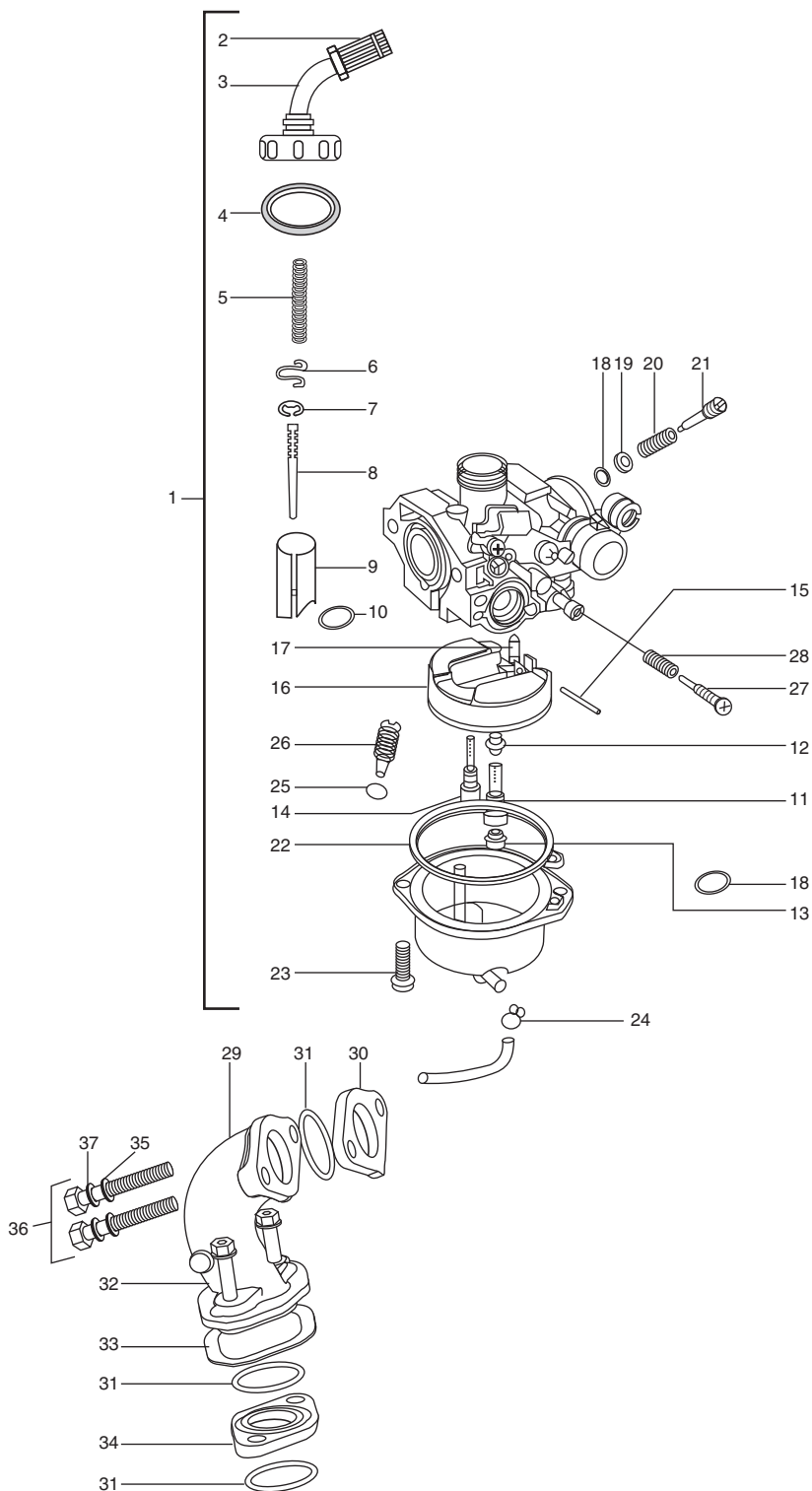

## INSPECTION

Check float pin for wear and damage. Replace, if necessary.

Fig. A

Check float level height by vernier, replace, if not O.K.

Fig. A

Replace 'O' ring for float chamber, (if required).

Check throttle valve and bore for wear, replace throttle valve / carburettor, if required.

Fig. B

Check idle screw and its spring for damage.

Check air screw, spring and its 'O' ring.

Fig. D

## ASSEMBLING

Screw fit the slow jet (ensure that 6 holes are clearly visible on the slow jet body).

Fix holder needle jet from main jet hole and tap gently (ensure that the smaller dia face towards carburettor body hole).

Tighten main jet on the jet holder (ensure that 20 holes are clearly visible on the jet holder body).

Screw the main jet alongwith jet holder.

Place the float valve needle into its seat while holding the float in place with the tab hooked into the needle hanger.

Insert the float arm pin through the pivot and the float.

Fix the float chamber and fit the drain pipe. Tighten the drain screw, by screw driver.

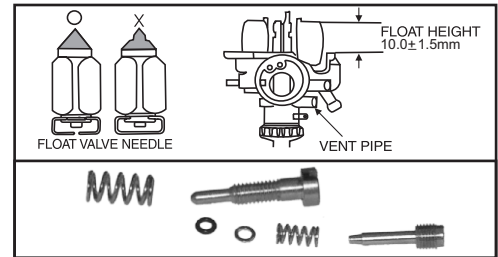

Fig. A

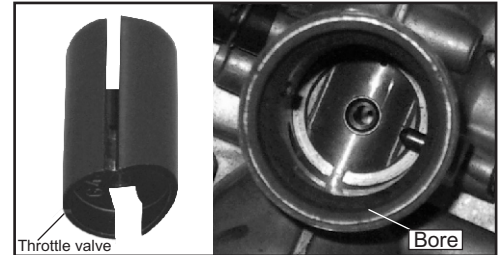

Fig. B



Fig. C

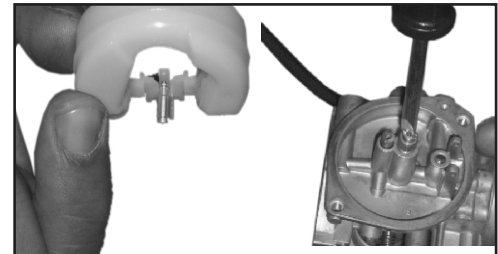

Fig. D

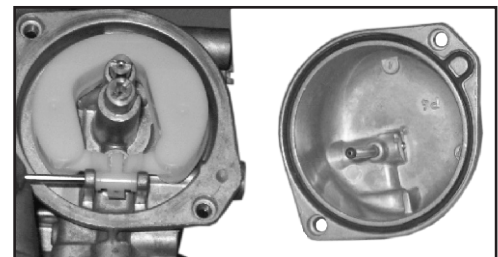

Fig. E



Fig. F

## FUEL SYSTEM

Fix idle screw and air screw alongwith spring (initial air screw setting 1½ turns out).

Insert the jet needle alongwith clip and plate into the throttle valve (ensure that needle lock clip is in 3rd groove position from the top.)

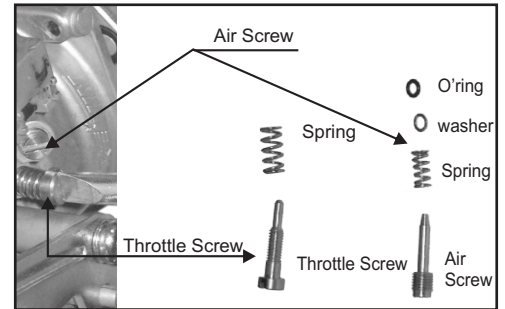

Fig. A

To reattach the throttle valve to the accelerator cable first compress the spring into the cap. Insert the tip of the cable through the slot in the throttle valve base and fix cable in long slit at rest position.

Align the groove on the side of the throttle valve with the guide pin in the carburettor body. Check for its smooth movement.

Tighten the top cap cover of carburettor body.

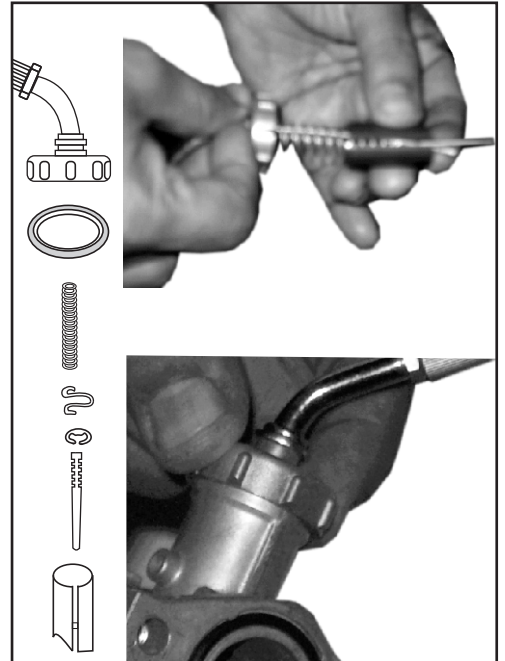

Fig. B

Take new insulator 'O' ring and fit in carburettor, groove on mounting face.

Fig. B

Install carburettor on inlet manifold with the help of socket head screw.

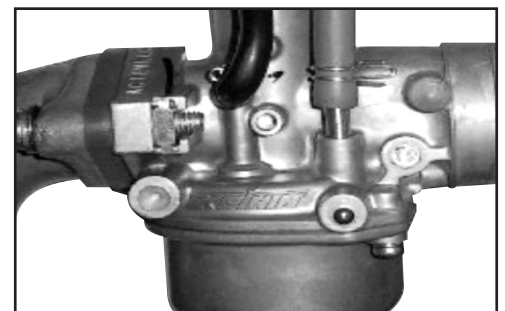

Fig. C

Fix choke cable into choke actuating lever.

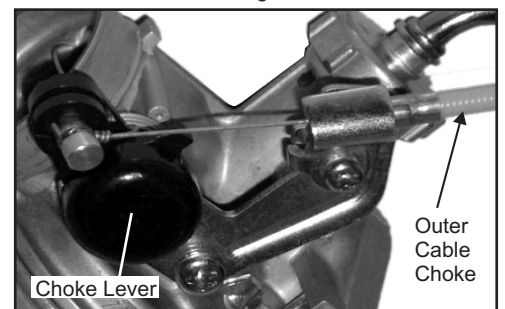

Fig. D



**CARBURETTOR ADJUSTMENT PROCEDURE**

After installation of carburettor for its tuning, follow the procedure given below -

Warm up the engine to the normal running temperature by running of approx. 3 kms.

Adjust idling speed to 1200 rpm by throttle stop (idle) screw.

Turn the air screw all the way inside until it seats lightly in the carburettor body.

Take care that excessively tightening of Air screw will damage its tip portion.

Engine stops - O.K. (incase does not stop, check for air leakage from insulator or 'O' ring and rectify.)

Adjust air screw position at 1½ turns out.

Start the engine and raise idling speed by turning the idle screw till the engine speed increases in the range of 1500 to 1600 rpm.

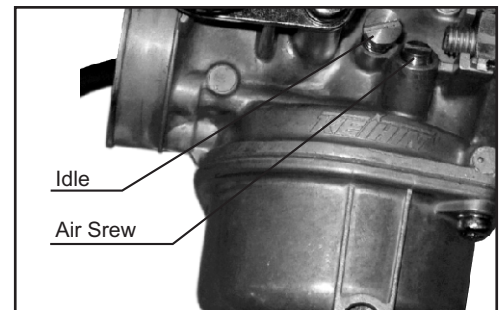

Fig. A

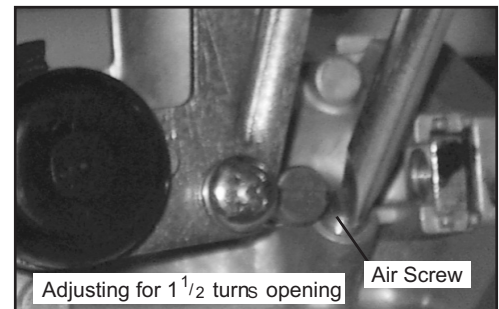

Fig. B



Fig. C

## FUEL SYSTEM

Open or close the air screw slowly and observe that engine rpm increases at a particular opening. Engine rpm will start reducing if it is further screwed in / Out. This is the setting point of the air screw. This air screw opening should be in the range of 1 to 2 turns out. It varies from vehicle to vehicle.

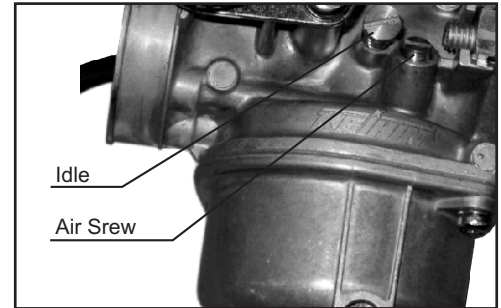

Fig. A

Re-adjust idling speed to  $1200 \pm 100$  rpm by adjusting the idle screw and ensure that exhaust emission CO% is as specified. (CO% 2.0).



Fig. B

After adjusting idling speed, check for its stability / flat spot / missing if any, by accelerating and running the vehicle.

### NOTE :

Do not apply force or overtight the air screw. Damage may occur incase the air screw is being tightened against the air screw seat.

Incase the idle speed is too low engine will stall, if it is too high it will cause excessive fuel consumption.





### NOTE :

While running engine in idling speed turn the handle bar to the extreme left or right hand side, if any change in idling speed is noticed, the accelerator cable may be wrongly routed or improperly adjusted. Correct the same before test ride.

---

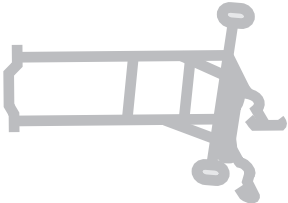
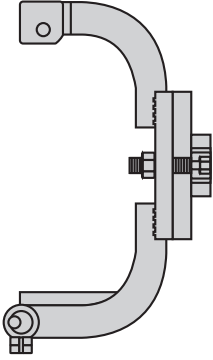
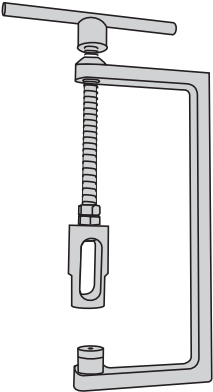
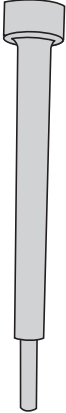
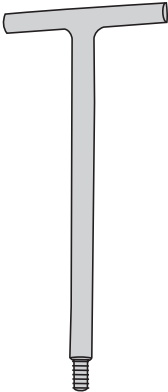
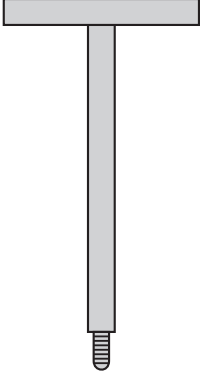
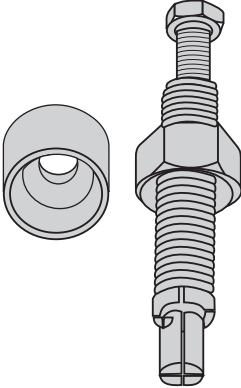
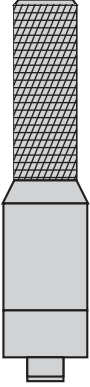
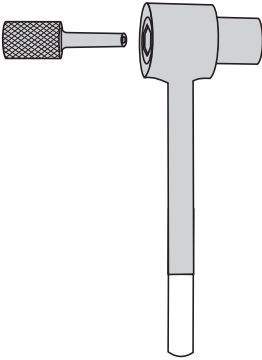
## **SPECIAL SERVICE TOOLS**

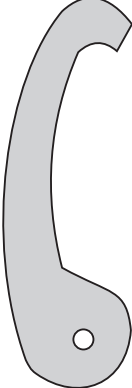
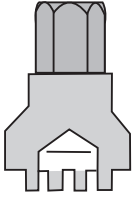
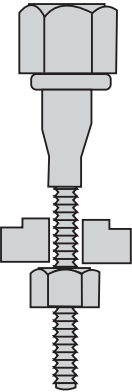

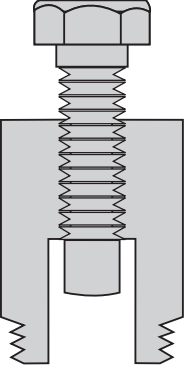
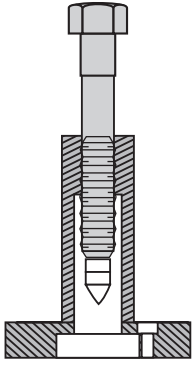
# SPECIAL SERVICE TOOLS

 <p>1</p>	 <p>2</p>	 <p>3</p>	 <p>4</p>
 <p>5</p>	 <p>6</p>	 <p>7</p>	 <p>8</p>
 <p>9</p>	 <p>10</p>	 <p>11</p>	 <p>12</p>
 <p>13</p>	 <p>14</p>	 <p>15</p>	 <p>16</p>

**SPECIAL SERVICE TOOLS**

<b>S.NO.</b>	<b>DESCRIPTION</b>	<b>NEW PART NO.</b>
1.	Scooter stand trolley type	<b>H-2391551</b>
2.	Fixture base plate stand	<b>H-2391566</b>
3.	Tool for taking out intel and exhaust valve	<b>F-1375450</b>
4.	Arbor valve guide	<b>T-3375511</b>
5.	Tool for removing rocker shaft	<b>H-3391552</b>
6.	Tool for removing cam shaft	<b>T-3375512</b>
7.	Bearing extractor with collet and spacer for cam shaft ball bearing from cyl. head	<b>H-3391553</b>
8.	Punch for assy. cam shaft ball bearing in cylinder	<b>H-3391523</b>
9.	Tappet gap adjusting tool set	<b>T-3377865</b>
10.	Punch for wrist pin	<b>H-3391516</b>
11.	Wrench for clutch assembly	<b>H-3391517</b>
12.	Wrench for clutch nut	<b>H-3391515</b>
13.	Tool for assy. and dismantling clutch	<b>H-1391524</b>
14.	Locking tool for fly wheel	<b>H-3391518</b>
15.	Fly wheel extractor	<b>H-3391519</b>
16.	Tool for separating crank case and expelling crank shaft	<b>H-3391520</b>

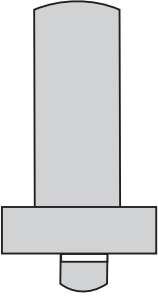
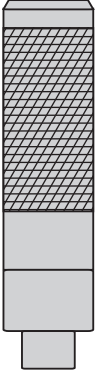
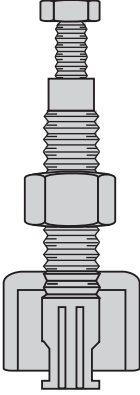
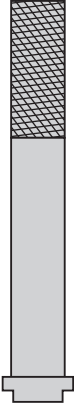
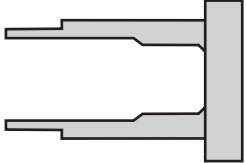
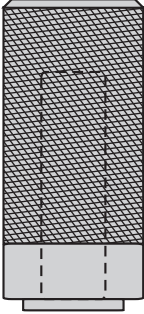
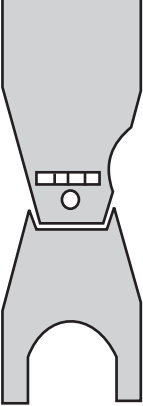
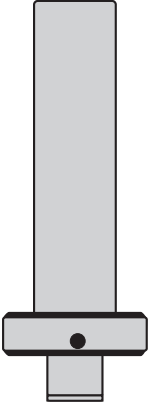
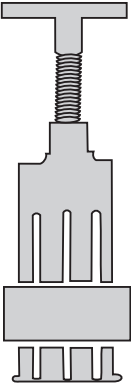
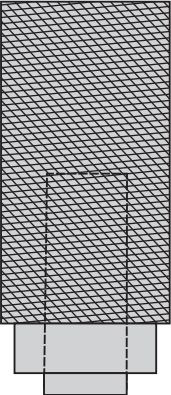

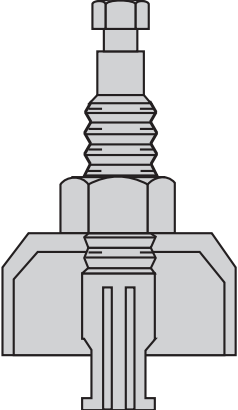
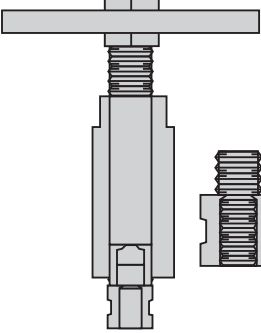
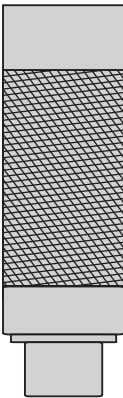
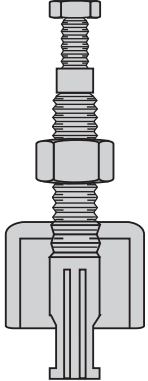

# SPECIAL SERVICE TOOLS

 <p>20</p>	 <p>24</p>	 <p>28</p>	 <p>32</p>
 <p>19</p>	 <p>23</p>	 <p>27</p>	 <p>31</p>
 <p>18</p>	 <p>22</p>	 <p>26</p>	 <p>30</p>
 <p>17</p>	 <p>21</p>	 <p>25</p>	 <p>29</p>

**SPECIAL SERVICE TOOLS**

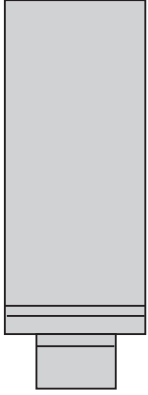
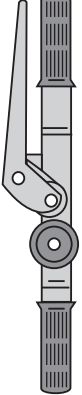
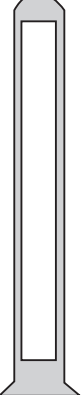
<b>S.NO.</b>	<b>DESCRIPTION</b>	<b>NEW PART NO.</b>
17.	Extractor crank shaft ball bearing flywheel side	<b>H-3391554</b>
18.	Bearing extractor from crank shaft	<b>H-1391608</b>
19.	Jig for crank shaft alignment	<b>H-1391528</b>
20.	Punch for assy. ball bearing in crank case flywheel side	<b>H-3391531</b>
21.	Tool with adaptor for assy. ball bearing on crank shaft clutch side.	<b>F-2375558</b>
	Adaptor (To be use with tool No. F-2375558)	<b>F-2375558/4</b>
22.	Punch for assy. oil seal flywheel side	<b>H-3391532</b>
23.	Punch for assy. kick shaft oil seal	<b>H-3391555</b>
24.	Punch for expelling needle roller bearing from idler gear	<b>H-3391556</b>
25.	Punch for assy. needle roller bearing in idler gear	<b>H-3391557</b>
26..	Punch for extracting drive shaft	<b>H-2391522</b>
27.	Feeler gauge for checking axial play of gears	<b>G-2107025</b>
28.	Extractor with collet & spacer for drive shaft ball bearing from crank case	<b>H-3391558</b>
29.	Extractor with collet and spacer for drive shaft needle roller Bearing	<b>H-3391559</b>
30.	Punch for assy. drive shaft needle roller bearing (Flywheel side)	<b>H-3391529</b>
31.	Punch for assy. drive shaft ball bearing in crank case	<b>H-3391560</b>
32.	Punch for assy. drive shaft oil seal in crank case	<b>H-3391561</b>

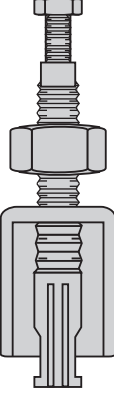
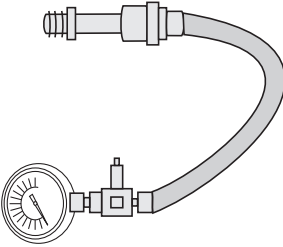
# SPECIAL SERVICE TOOLS

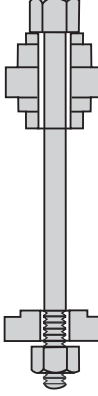
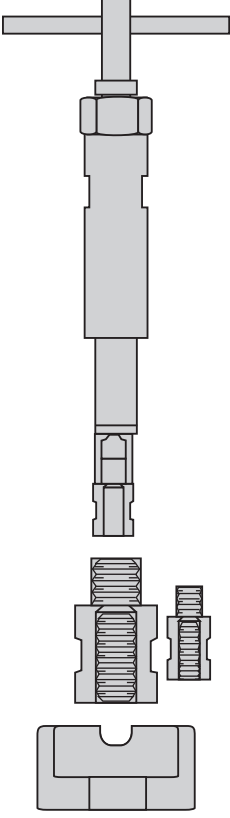
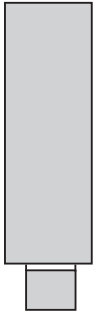
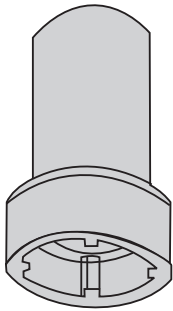
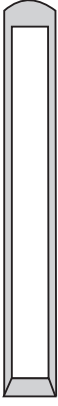
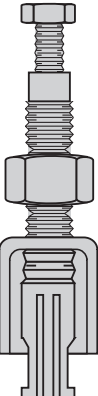
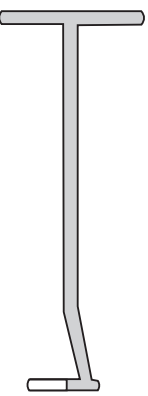
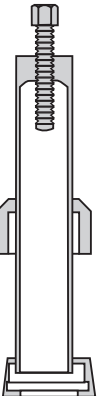











 <p>35</p>	 <p>39</p>	 <p>43</p>	 <p>47</p>
 <p>34</p>	 <p>38</p>	 <p>42</p>	 <p>46</p>
 <p>33</p>	 <p>37</p>	 <p>41</p>	 <p>45</p>
 <p>36</p>	 <p>40</p>	 <p>44</p>	

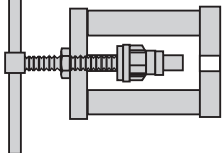
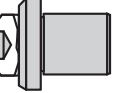

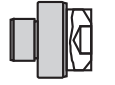
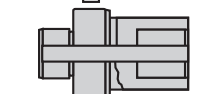
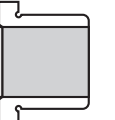
**SPECIAL SERVICE TOOLS**

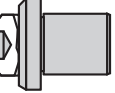
<b>S.NO.</b>	<b>DESCRIPTION</b>	<b>NEW PART NO.</b>
33.	Tool with adoptor & cap for assy. crank shaft/drive shaft in crank case	<b>F-2306849</b>
	Adoptor for assy. crank shaft (To be used with tool no. F-2306849)	<b>F-2306849/1</b>
	Cap for assy. crank shaft (To be used with tool no. F-2306849)	<b>F-2306849/2</b>
	Adoptor for assy. drive shaft (To be used with tool no. F-2306849)	<b>F-2306849/3</b>
34.	Extractor with collet and spacer for spring gear ball bearing flywheel side	<b>H-3391562</b>
35.	Punch for assy. ball bearing spring gear assy. in crank case flywheel side	<b>H-3391563</b>
36.	Extractor with collet & spacer for spring gear needle roller bearing (Clutch side)	<b>H-3391564</b>
37.	Punch for assy. needle roller bearing spring gear (Clutch side)	<b>H-3391565</b>
38.	Compression tester with adaptor	<b>X-4576002</b>
39.	Tool for fitting wind shield beading	<b>H-0391543</b>
40.	Tool for fuel cock	<b>RS-00231</b>
41.	Tool for track and ring nut (Steering column)	<b>H-3391533</b>
42.	Punch for dismantling lower track of upper of bearing	<b>H-1391534</b>
43.	Punch for dismantling upper track of lower of bearing	<b>H-1391534</b>
44.	Extractor for lower track of lower bearing	<b>H-1391536</b>
45.	Punch for assy. lower track of lower bearing	<b>H-2391537</b>
46.	Fixture for assy. of lower track of upper bearing and upper track of lower bearing of steering column	<b>H-2391538</b>
47.	Punch for assy. roller bearing in front jaw plate from out side	<b>H-3391539</b>

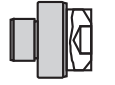
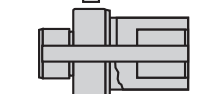
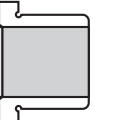
# SPECIAL SERVICE TOOLS

**SPECIAL SERVICE TOOLS**

<b>S.NO.</b>	<b>DESCRIPTION</b>	<b>NEW PART NO.</b>
48.	Punch for assy. roller bearing in front jaw plate from inside	<b>H-3391540</b>
49.	Punch for assy. roller bearing in front brake drum	<b>H- 3391541</b>
50.	Fixture for overhauling front suspension with attachments	<b>H-0391542</b>
	Mandrel (To be used with tool no. H-0391542)	<b>H-0391542/1</b>
	Mandrel (To be used with tool no. H-391542)	<b>H-0391542/2</b>
	Locator (To be used with tool no. H-0391542)	<b>H-0391542/3</b>
	Spacer (To be used with tool no. H-0391542)	<b>H-0391542/4</b>
	Tool for front suspension (To be used with tool no. H-0391542)	<b>H-0391542/5</b>
	Pressure Pad (To be used with tool no. H-0391542)	<b>H-0391542/16</b>
	Washer (To be used with tool no. H-0391542)	<b>H-0391542/17</b>
	Bush (To be used with tool no. H-0391542)	<b>H-0391542/18</b>
	Mandrel (To be used with tool no. H-0391542)	<b>H-0391542/20</b>
	Mandrel (To be used with tool no. H-0391542)	<b>H-0391542/21</b>
	Mandrel (To be used with tool no. H-0391542)	<b>H-0391542/22</b>
	Pin (To be used with tool no. H-0391542)	<b>H-0391542/28</b>

---

# ENGINE

## INDEX

	<b>PAGE No.</b>
GENERAL SERVICE DETAILS	73
ENGINE REMOVAL	74
INSPECTION	75
ENGINE INSTALLATION	76

## GENERAL SERVICE DETAILS

Following sub-assemblies can be serviced without removal of engine from the vehicle.

Carburettor  
Magneto assy.  
Starter motor  
Air filter  
Paper element filter  
Oil strainer  
Rear brake assy.  
Gear control bracket assy.  
Clutch assy.  
Silent chain, sprocket pinion set, cam shaft  
Cylinder head / valves  
Cylinder block / piston set

For following parts, removal of engine from vehicle is necessary :-

Crank case assy. LH & RH  
Crank shaft assy.  
Counter shaft assy.  
Drive shaft assy.  
Engine dry weight.....**33.7 kg.**  
Engine oil capacity.....**850 ml.**

## TORQUE VALUES

Screw for air bellow - **0.7 kg-m.**  
Engine mtg. bolt/nut to link - **6.0 - 7.5 kg-m.**  
Rear shocker lower bolt/nut - **3.0 - 3.5 kg-m.**

# ENGINE

## ENGINE REMOVAL

Put scooter on stand on level surface.

Drain out engine oil by unscrewing drain plug.  
Fig. A

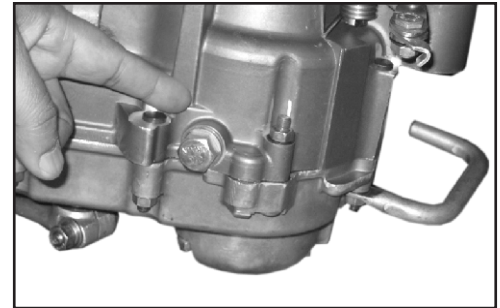

Fig. A

**Remove following from carburettor**  
Fig. B.

Close fuel tap and fuel pipe from carburettor inlet.

Open top cover assy. of carburettor.

Remove throttle cable by taking out cable end from throttle valve.

Remove choke cable from bracket for choke in carburettor.

Remove air bellow by loosening clamp screw and taking out from carburettor inlet.

Disconnect all electrical connections from magneto / LT socket.

Remove gear control bracket cover by opening bolt.  
Fig. C

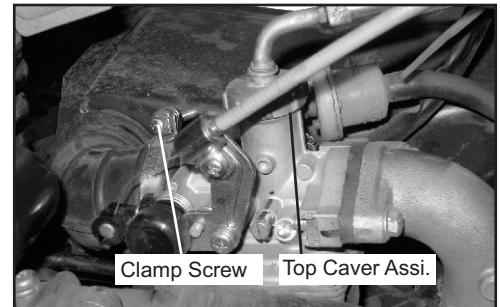

Fig. B

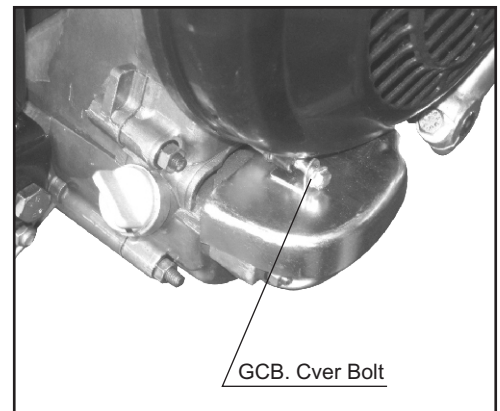

Fig. C

Disconnect gear control cables from gear control bracket by loosening the cable nipple bolt.

Remove rear brake cable by loosening cable adjusting screw and opening the brake cable securing bolt / nut from rear brake lever assembly.  
Fig. D

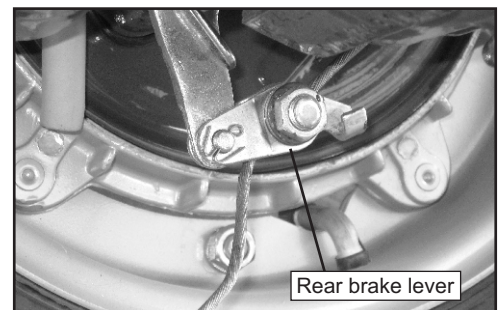

Fig. D

Open clutch control cable from clutch outer lever by loosening bolt / nut of link plate.

Fig. A

Support engine from bottom.

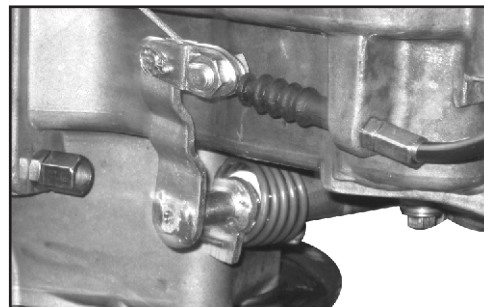

Fig. A

Open rear shock absorber bolt / nut from lower end.

Fig. B

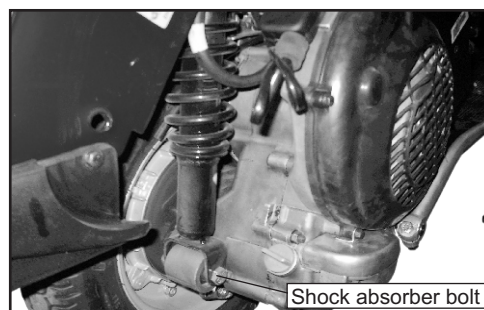

Fig. B

Open foundation bolt of engine to link assy. by opening nut and remove engine from link assy. of chassis alongwith rear wheel.

Fig. C



Fig. C

## INSPECTION

Check for the damage of rear shock absorber damper buffer. Replace, if required.

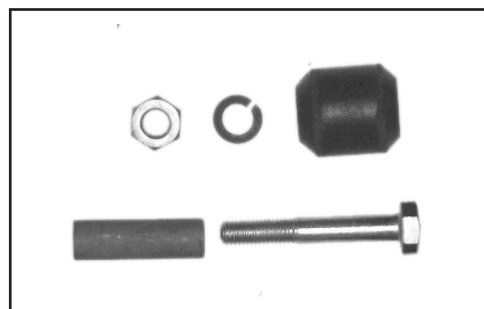

Fig. D

## ENGINE

### INSTALLATION

Place engine on support and in position with the bracket portion of link assy.

Insert mounting bolt from LH side of vehicle through link assy, spring washer and nut.  
Fig. A & B

Tightening Torque - **6.5 kg-m.**

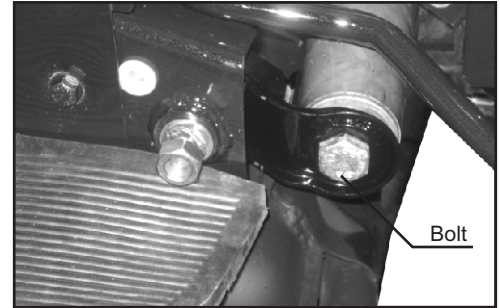

Fig. A

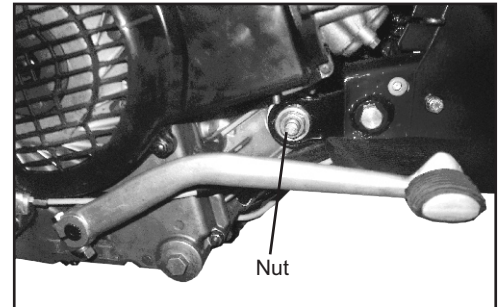

Fig. B

Lift the engine from rear side from the support and insert bolt through rear shock absorber keeping engine in between its bracket. Tighten nut with spring washer and lower mounting bolt.  
Fig. C

Tightening Torque. - **3.0 - 3.5 kg-m.**

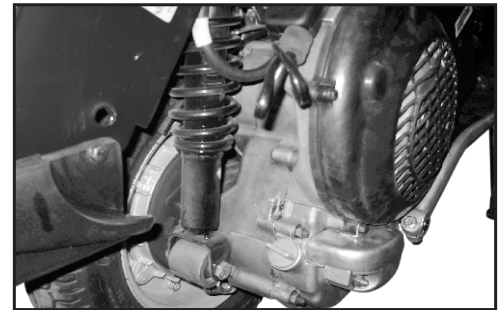

Fig. C

Fit brake cable through crank case adjusting screw and tighten to brake link assy.  
Fig. D



Fig. D

Check proper fitment of lever return spring of brake.

Adjust brake pedal free play to **5.0 mm**.

No braking should take place, if pedal is pressed by 5.0 mm.

Fig. A



Fig. A

Fit clutch cable to clamp assy. of outer lever passing through adjusting screw.

Fig. B

Adjust clutch lever free play to **2-3 mm**. by adjusting the adjusting screw.

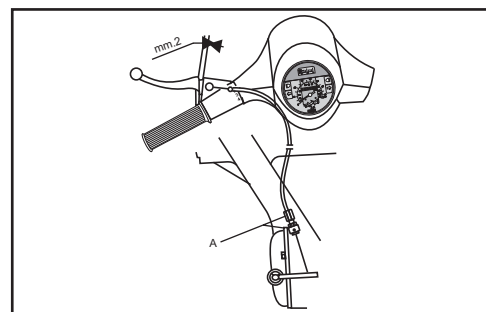

Fig. B

Connect gear cables to sector of gear control bracket passing through adjusting screws keeping the gear control lever in neutral position, tighten screws for cable nipple.

Fig. C

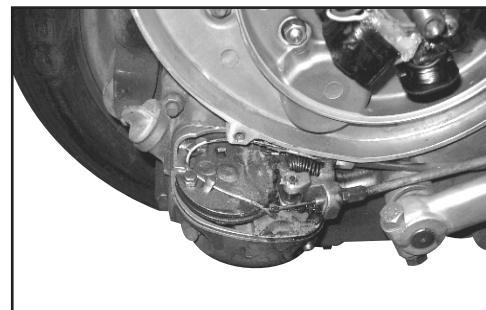

Fig. C

Adjust the play of cables, to have neutral position at '0' mark on handle bar by adjusting both cables.

Fit gear control bracket cover.

Connect air bellow hose of air cleaner assy. to carburettor inlet manifold by tightening clamp screw.

Fig. D



Fig. D



## ENGINE

---

Connect all electrical connections of magneto and LT socket and starter motor.

Fig. A

Connect followings to Carburettor

Choke cable

Throttle cable

Fuel tube

Fig. B

Fit cowl assy. LH & RH

Take trial run of scooter to check control cable adjustments.

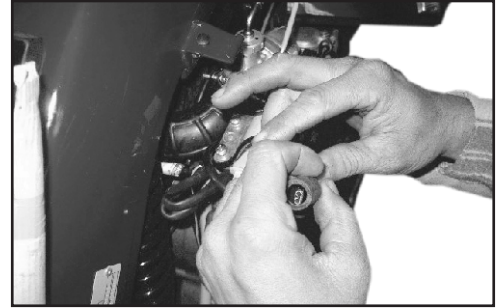

Fig. A

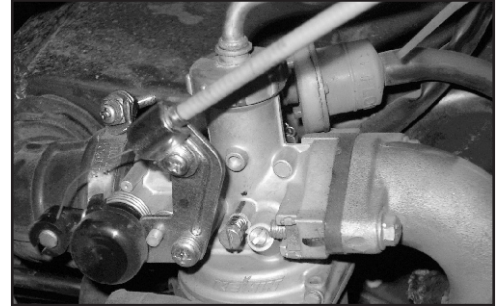

Fig. B

## CYLINDER HEAD / VALVES

### INDEX

	PAGE No.
GENERAL SERVICE DETAILS	79
FAN COVER AND COOLING HOODS	80
CYLINDER HEAD REMOVAL	81
CYLINDER HEAD DISSEMBLY	84
VALVES AND VALVE SEAT	86
CYLINDER HEAD ASSEMBLY	91
CYLINDER HEAD INSTALLATION	93

### GENERAL SERVICE DETAILS

For the service of rocker arms, cam shaft, cylinder head and valves, engine must be removed from the chassis. All the disassembled parts must be cleaned with cleaning solvent and then dried by compressed air before inspection. Oil must be passed from the passage provided in the cylinder head for the lubrication of cam shaft and rocker arm. Before the assembly of cylinder head oil passage must be cleaned. At the time of disassembling, parts should be marked and stored, to prevent the difficulty during reassembly. During the cleaning and servicing the mating part of the head may not get damaged, for this care is to be taken.

### SPECIFICATIONS

#### CYLINDER HEAD / VALVES

ITEM		STANDARD	SER. LIMIT
Cylinder compression		10.0 ± 2.0 kg.cm <sup>2</sup>	-
Valve clearance (cold)	Inlet	0.06 ± 0.01 mm.	-
	Exhaust	0.08 ± 0.01 mm.	-
Camshaft cam lobe height		IN / EX	29.488 - 29.493 mm.
Valve	Stem O.D	Inlet	4.975 - 4.990 mm.
		Exhaust	4.955 - 4.970 mm.
	Guide I.D	Inlet	5.00 - 5.017 mm.
		Exhaust	5.003 - 4.987 mm.
	Stem to guide clearance	Inlet	0.010 - 0.042 mm.
		Exhaust	0.017 - 0.048 mm.
Spring free length		Inner / Outer	30.66 - 33.66 mm
Valve seat width		0.9 - 1.1 mm.	1.5
Cylinder Head Warpage		0.05 mm. max.	-

## CYLINDER HEAD / VALVES

---

### FAN COVER, LH & RH COOLING COVERS REMOVAL / INSTALLATION

#### REMOVAL

Remove carburettor, by opening 2 nos. of socket head screws.

Open inlet manifold by opening 2 nos. flange head screws & also remove the packing insulation with 'O' ring.

Cover cylinder head inlet to avoid dust entry.

Open spark plug and cover the hole to avoid dust entry.

Remove rear wheel by opening nut and open silencer mounting bolt and 2 nos. nut from exhaust pipe mouth area.

Open GCB cover by opening one bolt.

Open magneto cover 3 bolts and 2 self tapping screws and take out cover.

Open 2 screws & 1 bolt for cooling hoods and take out LH & RH hoods.

#### INSPECTION

Check for damages of fan cover, LH & RH hood and replace, if required.

#### INSTALLATION

Installation is reverse of removal.

While installing all sub-assemblies use new 'O'rings and new gaskets.

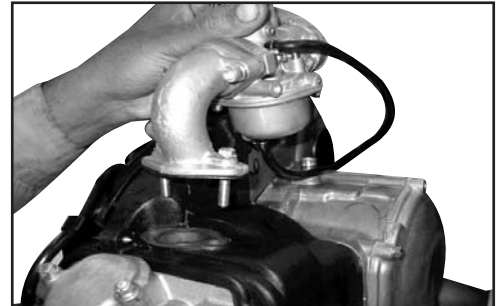

Fig. A



Fig. B

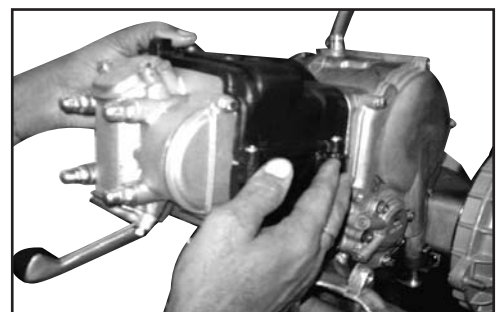

Fig. C

**CYLINDER HEAD ASSEMBLY**

**REMOVAL**

Open clutch cover by opening nuts and bolts.

Open LH cover (Timing chain cover) by opening 2 bolts.



Fig. A

Open tappet inspection covers by opening 4 bolts.

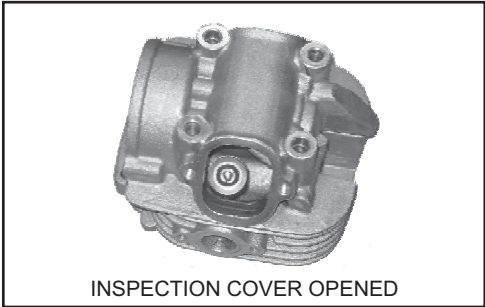

Fig. B

Rotate magneto to bring piston on top dead center position. To ensure this check as below –

- Mark 'I' on cam sprocket is matching with index screw.
- Match marking on rotar fan and fan cover.
- Rocker arms are having some free play.

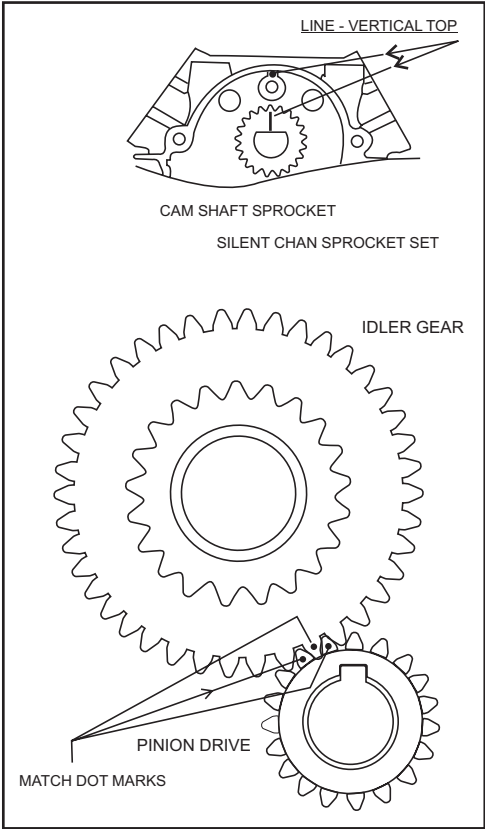

Fig. C

## CYLINDER HEAD / VALVES

Loosen timing chain by operating lifter chain tensioner screw (in cylinder block) clockwise to retracted position  
Fig. A

Remove the lifter tensioner assy. and gasket by opening 2 flange bolts.

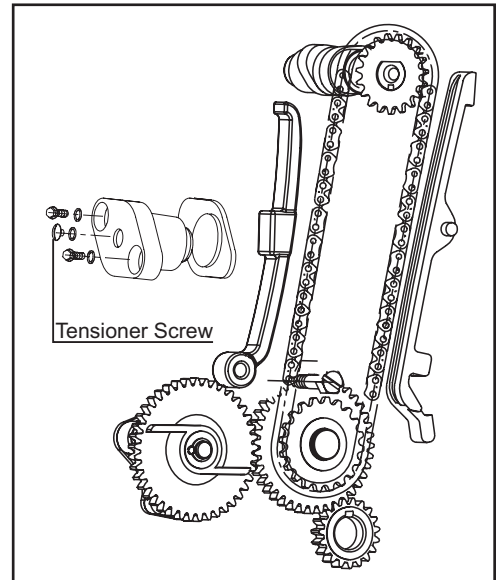

Fig. A

Open cam sprocket bolt and take out bolt, washers, sprocket and bush for sprocket fixing.  
Fig. B

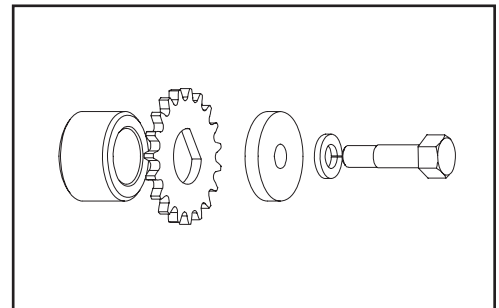

Fig. B

Take out the timing chain by slipping it from cam sprocket and sprocket on idler gear.  
Fig. C

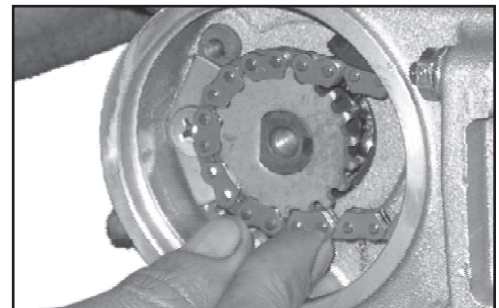

Fig. C

## CYLINDER HEAD / VALVES

Open 4 nos. of cap nuts of cylinder head diagonally in 2 - 3 steps evenly.

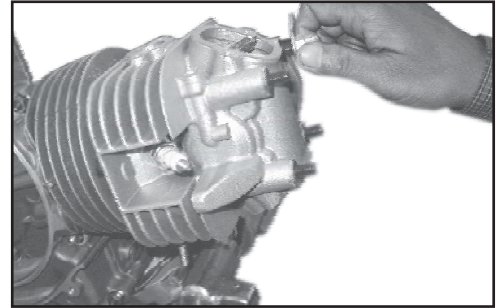

Fig.A

Open 2 nuts holding cylinder head and cylinder block.

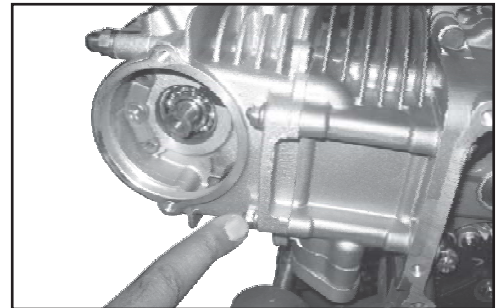

Fig. B

Take out cylinder head assy. By sliding it upwards.

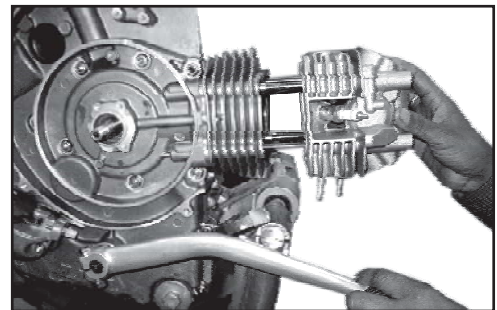

Fig. C

Remove 2 nos. of dowels and cylinder head gasket. Check the locations of dowels.

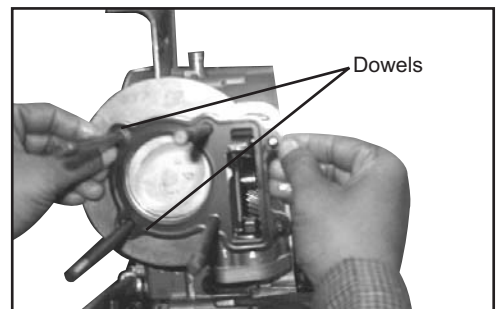

Fig. D

## CYLINDER HEAD / VALVES

### CAM CHAIN TENSIONER LIFTER

Check lifter operation

- Tensioner on pressing from top point, should not go inside the body.
- When turned in clockwise rotation it should pull back inside the body. On removing the screw driver, shaft jumps out of body due to spring pressure to full length.

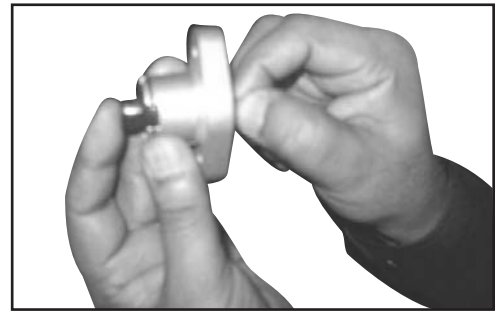

Fig. A



Fig. B

### CAM CHAIN GUIDE / TENSIONER SILENT CHAIN

Take out cam chain guide by pulling out.

Take out tensioner silent chain by opening pivot bolt.

Check for excessive wear or damage.

### CYLINDER HEAD DISSEMBLY

#### Rocker Arm

Remove counter sunk screw & take out rocker shaft plate.

Use special Tool No. **H-3391552** for removing rocker arm shaft and rocker arm assemblies.



Fig. C

Fit special tool into the threading of rocker arm shaft and pull.

Remove rocker arm assembly.

Take out needle cage bearing from arm bore.

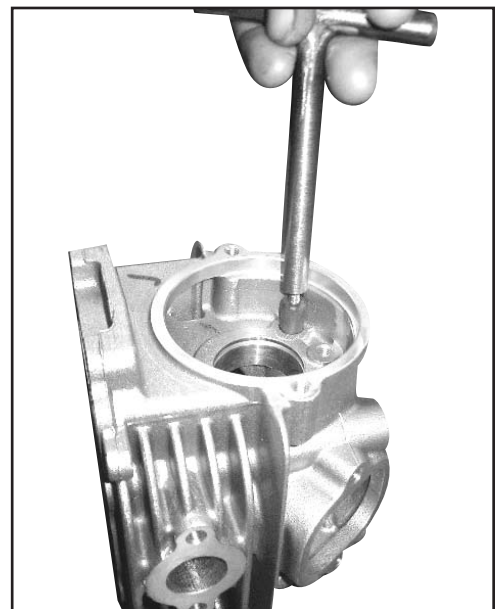

Fig. D

Remove circlip from the cam shaft bore with internal nose pliers.  
Fig. A

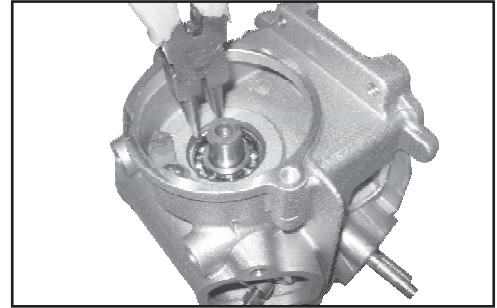

Fig. A

Use special Tool No. **T-3375512** for removing cam shaft with bearing.  
Fig. B

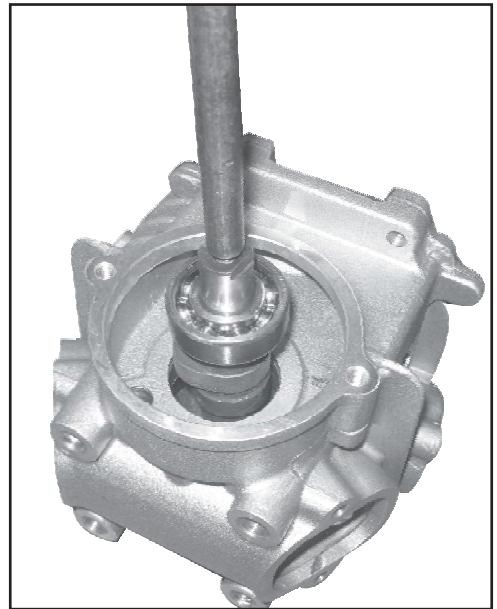

Fig. B

Fit tool into the threading of cam shaft and pull out the cam shaft bearing assembly. It may require tapping by plastic hammer in some cases, for removal.  
Fig. C

Take out bearing at rear end (spark plug) side of cylinder head with the help of special Tool No. **H-3391553**  
Fig. C

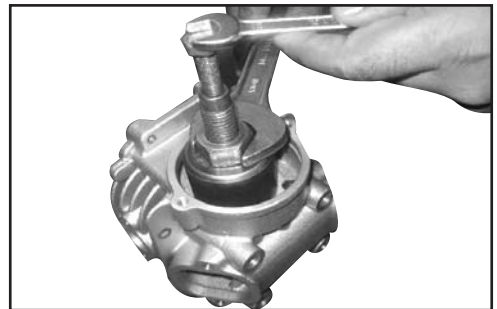

Fig. C



## CYLINDER HEAD / VALVES

### INSPECTION

Check rocker arm assy. parts for wear and damage.

Check play between rocker arm needle roller bearings and shafts. If required replace needle cage bearing.

Check for clogged oil holes, in cam shaft.

Check each cam lobe for wear, scratches or scoring.

Measure the cam lobe height.

### Standard

Inlet	:	29.488+ - 0.020
Exhaust	:	29.493+ - 0.020

### Service limit

Intet	:	29.448
Exhaust	:	29.453

Cam shaft bearings should be inspected for free rotation and it should not be free on cam shaft O.D check for play of bearing, it should not be noisy, on rotation. Replace, if necessary.

### CYLINDER HEAD VALVES

For inlet and exhaust valves

By using special Tool No. **F-1375450** compress the valve springs and remove valve cottors first.

Take out retainer, valve springs and valve.

Take out valve stem seals.

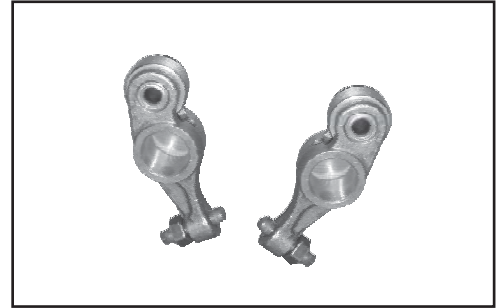

Fig. A



Fig. B



Fig. C

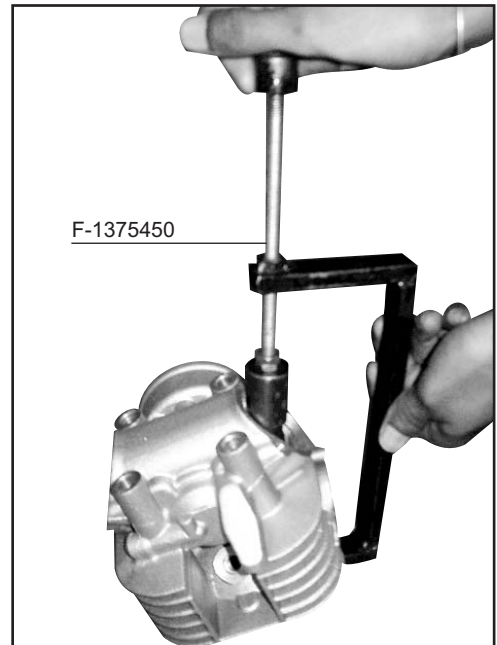

Fig. D

**INSPECTION OF CYLINDER HEAD**

Clean the cylinder head gasket joining area for any deposits.

Remove carbon deposits in combustion area and from valve stems, valve seats and spark plug area.

Check for any cracks developed near valve seats and spark plug hole area.

For checking of warpage of cylinder head, use feeler gauge and straight edge.

Put straight edge on cylinder head on plain surface and check by inserting feeler gauge.

Service limit - **0.05 mm.**

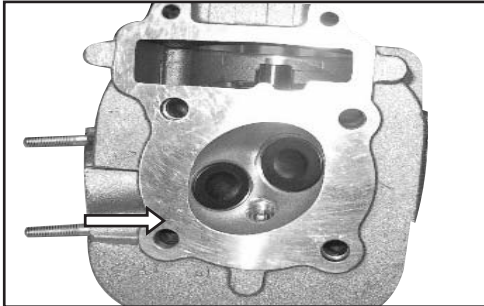

Fig. A

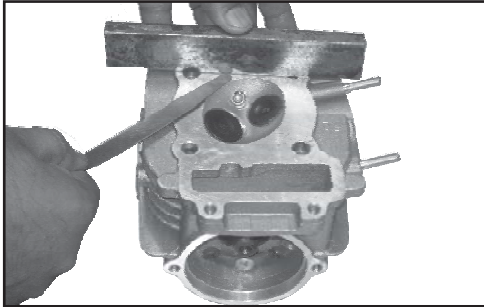

Fig. B

**VALVE SPRING**

Measure the free length –

Service limit	Outer	30.3 mm
	Inner	27.1 mm

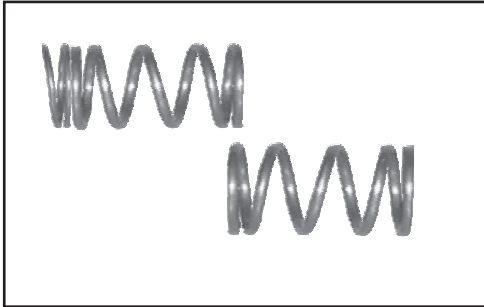

Fig. C

**VALVE / VALVE GUIDES**

Check valve for smooth movement into valve guide.

Check valves for abnormal wear, bending and burns.

Measure valve stem O.D.

Service limit - **4.90 mm.**

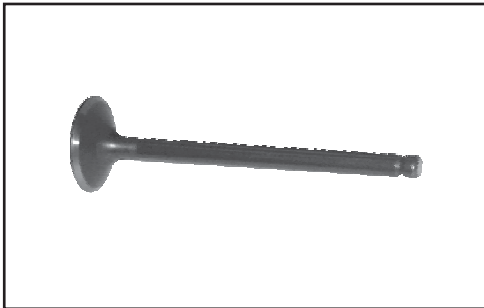

Fig. D

**NOTE :**

Inlet and Exhaust valves are not same.

## CYLINDER HEAD / VALVES

Use reamer to clean the valve guide carbon deposit. Reamer is to be inserted from valve seat side.

Valve guide reamer – **5.0 mm.**

Check for play between valve guide and valve stem by entering valve into guide.

If play is noticed, then valve guide is to be replaced.

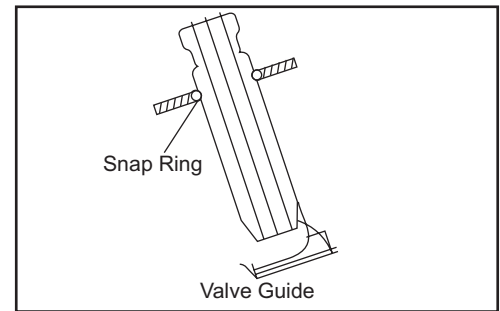

Fig. A

### Valve Guide Replacement

Heat the cylinder head to a temperature 130°C to 140°C on hot plate. (Never use welding torch for heating, this will warp the cylinder head). Temperature should not be more than 150°C.

Keep new valve guide in freezer for one hour.

Fit new snap ring to valve guide and press fit valve guide with snap ring from cam shaft side in hot condition of cylinder head upto snapping.

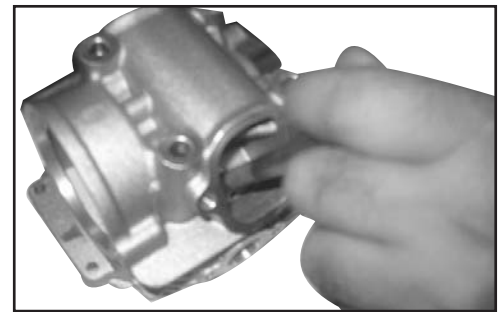

Fig. B

Valve arbor Tool No. **T-3375511** is to be used for fitment.

Let cylinder head cool to room temperature. Insert 5 mm. reamer and rotate in clockwise direction to remove any high spots / burrs.

Clean the valve seat and cylinder head properly.

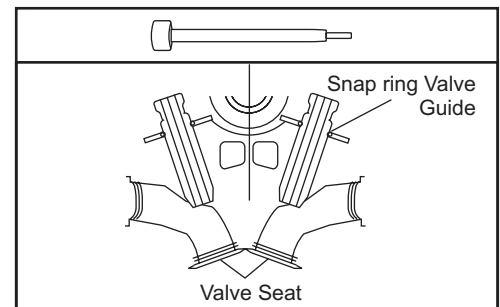

Fig. C

**VALVE SEAT INSPECTION**

Clean the valves properly.

Apply 'blue' to valve at its contact area with seat. Give minor strokes to valve to get impression of blue on valve seat (Do not rotate). Contact should be all around, even and within width tolerance.

- Width specified - **1.0 mm.**
- Discard limit - **1.5 mm.**

If the valve seat width is not as per specification, it is to be replaced.

For uneven seat width check for bend in valve stem.

If valve is bend or with damaged / uneven seat face, replace with new valve.

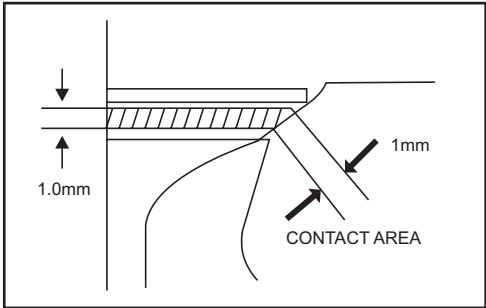

Fig. A

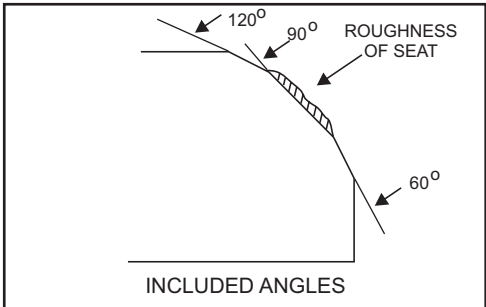

Fig. B

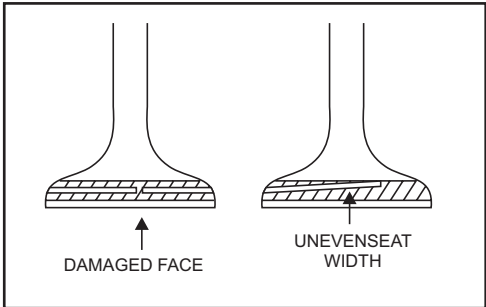

Fig. C

## CYLINDER HEAD / VALVES

### VALVE SEAT REFACING

Valve seats facing is specialised job and to be carried out by the professionals only.

Valve seat area is to be refaced as per the cutting details shown in the sketch with proper cutters.

- For 1. Use 32° cutter, if contact area is more.
- For 3. Use 60° cutter, if contact area is less.
- For 2. Seat face use 45° finish cutter.

Seat width standard is **1.0 mm**.

Do not grind seat more than necessary.

After cutting valve seat apply lapping compound and lap the valve with little pressure.

Wash properly after lapping the valve and valve seat and re-check the seat contact area using blue.

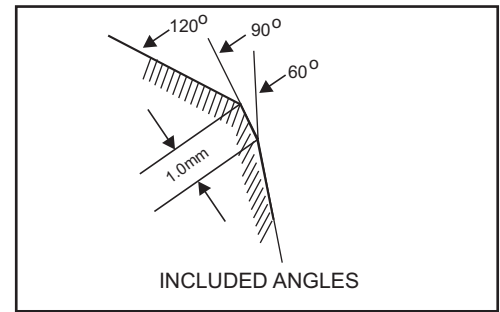

Fig. A

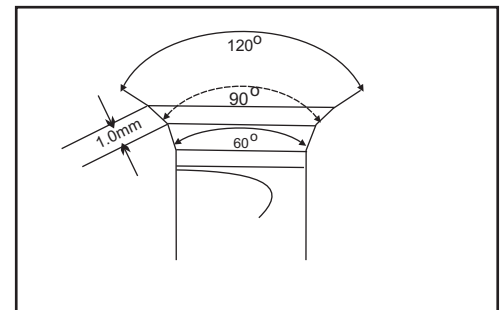

Fig. B

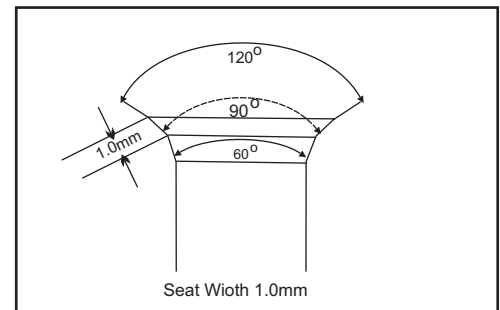

Fig. C

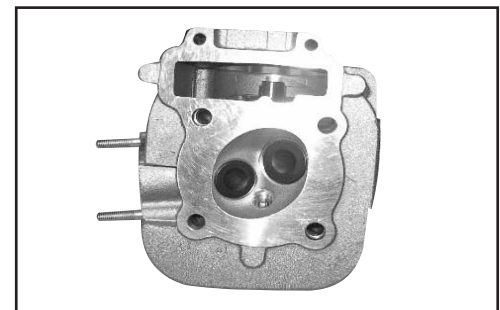

Fig. D

### CYLINDER HEAD ASSEMBLY

Blow compressed air in oil passages in cylinder head and cam shaft.

Use Tool No. **F-1375450** for assy. of valves.

Fit seat valve spring, with small oil on surface.

Insert valve stem with little oil from combustion chamber side.

Fit stem seal, inner and outer spring (Keep tight wound side of spring towards bottom on spring seat) and fit retainer.

Fig. B.

Compress springs and retainer by special tool and fit cotters, in its grooved location in valve stem. Use special Tool No. **F-1375450**.

Fig. C

Follow same process for both the valves.

Fit rear side ball bearing with special Tool No. **H-3391523**.

Fig. D

Apply clean engine oil to cam shaft and its bearing.

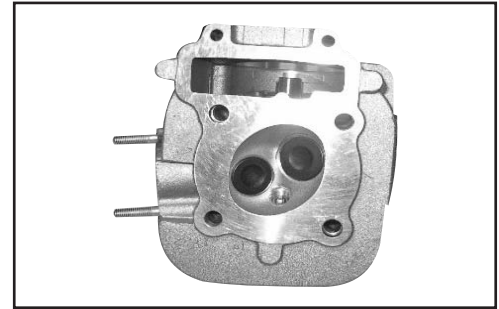

Fig. A

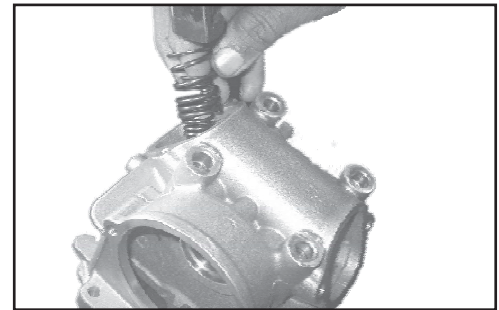

Fig. B



Fig. C

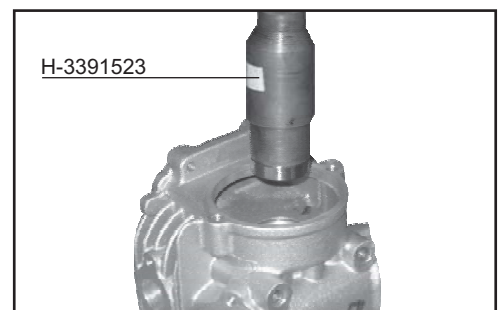

Fig. D

## CYLINDER HEAD / VALVES

Fit special Tool No. **T-3375512** to cam shaft and insert assembly into cylinder head. While inserting check that cam highest point is facing towards piston side.  
Fig. A

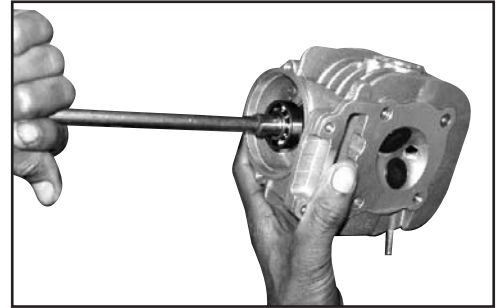

Fig. A

Fit cam shaft and remove special tool.  
Fig. B

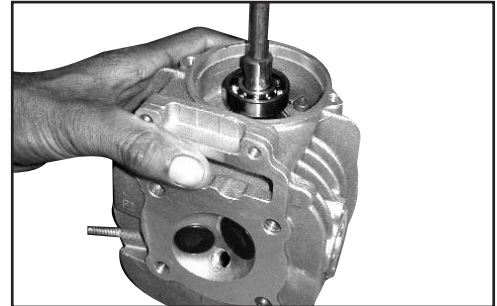

Fig. B

Fit circlip above the bearing in the groove for it.  
Fig. C

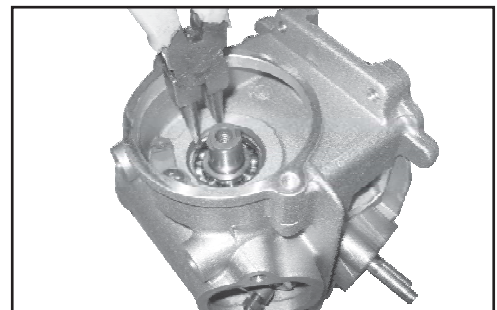

Fig. C

Take rocker arm shaft, rocker arm assembly, needle roller bearing and lubricate with engine oil.  
Fig. D

Fit needle roller bearing in rocker arms.

Fit rocker arm assy., spring washer by inserting rocker arm shaft by using Tool No. **H-3391552** into cylinder head.  
Fig. D.

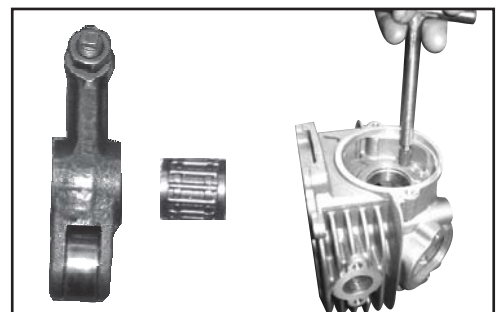

Fig. D

Remove special tool. Align rocker arm shafts by rotating so that plate for rocker arm can be fitted with the help of counter sunk screw.  
Fig. E

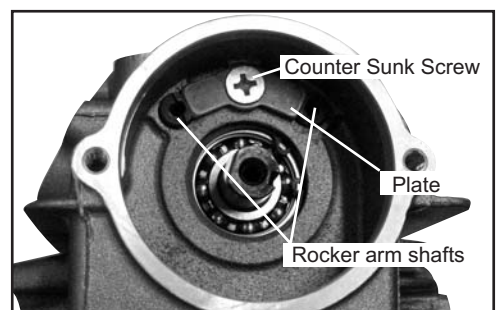

Fig. E

### CYLINDER HEAD INSTALLATION

Fit cylinder head gasket and 02 nos. of dowels.  
Fig. A

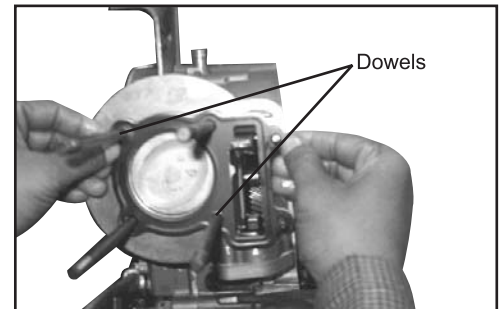

Fig. A

Fit cylinder head assy. by sliding it on studs.  
Fig. B

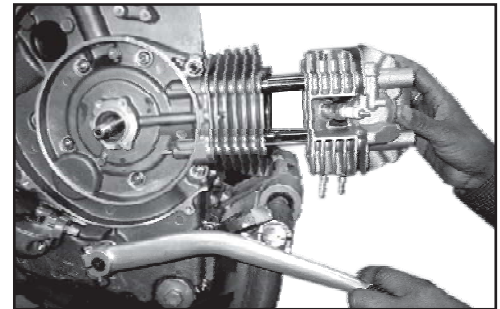

Fig. B

Fit 04 nos. gaskets and cap nuts on 04 studs of  
cylinder head and tighten them.  
Fig. C

Tightening Torque – **2.9 kg-m.**

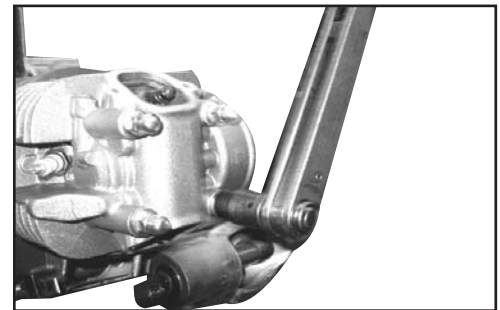

Fig. C

Fit 02 nos. of nuts with spring washer for securing  
cylinder head to block / crank case and tighten them.  
Fig. D

Tightening Torque – **1.1 kg-m.**

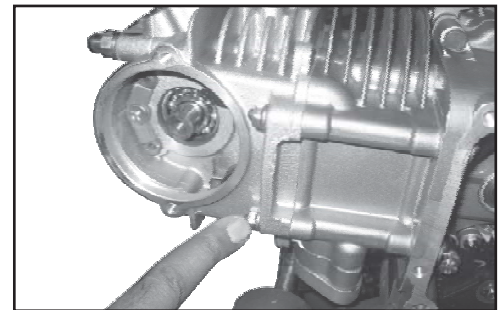

Fig. D



## CYLINDER HEAD / VALVES

Align dot marks on drive pinion and idler gear by lifting and rotating pinion gear.

Fit bush for cam sprocket.

Lubricate silent chain and fit it on idler gear sprocket and cam sprocket, and fit cam sprocket on cam shaft ensuring 'I' mark on cam sprocket is at vertical top and matching with the center mark (screw center) on cylinder head.

Fit plain washer, spring washer and tighten sprocket bolt.

Tightening Torque – **1.8 kg-m.**

Lubricate guide cam chain and fit into its groove by pushing and tensioner silent chain by pivot bolt.

Tightening Torque – **1.0 kg-m.**

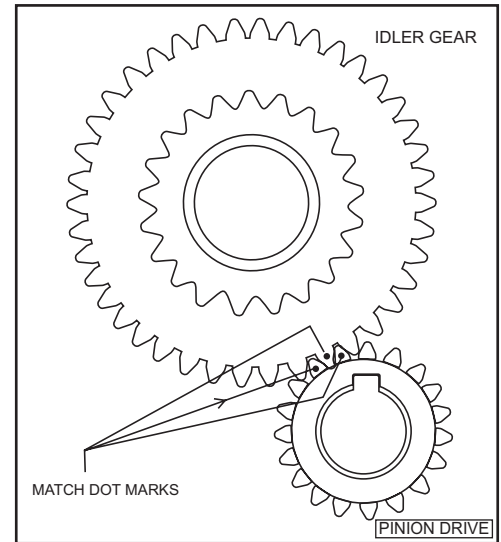

Fig. A

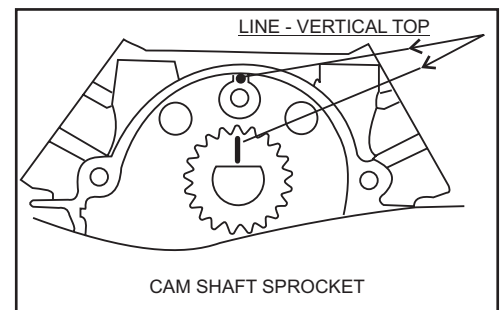

Fig. B

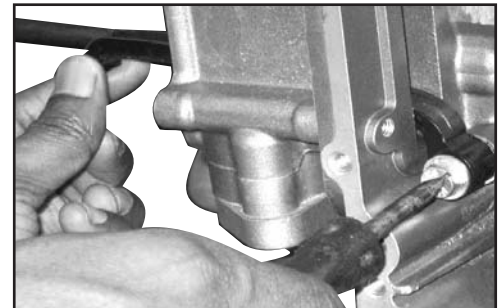

Fig. C

**CYLINDER HEAD / VALVES**

Take new gasket of tensioner lifter and lubricate with engine oil. Install lifter assy. tensioner with this gasket on cylinder block by flange bolt 2 nos.

Tightening Torque – **1.1 kg-m.**



Fig. A

Release lifter assy. tensioner by opening center screw by retracting fully and provide tension on cam chain.

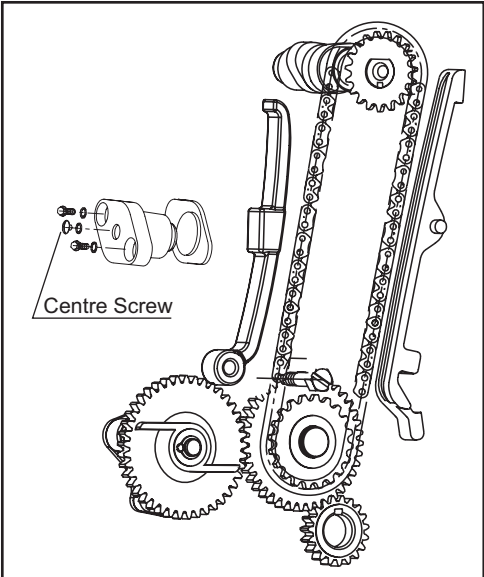
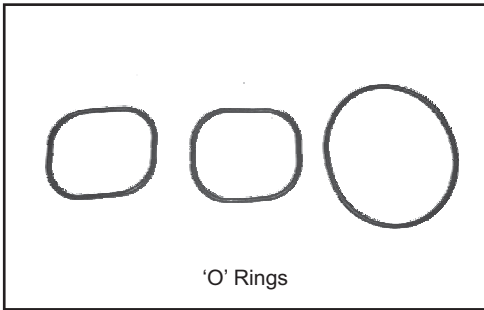

Fig. B



'O' Rings

Fig. C

Lubricate 'O' ring of LH cover and 'O' rings of tappet covers. Fit on cylinder head by 2 flanged bolts each. Fig. D

Tightening Torque – **1.2 kg-m.**

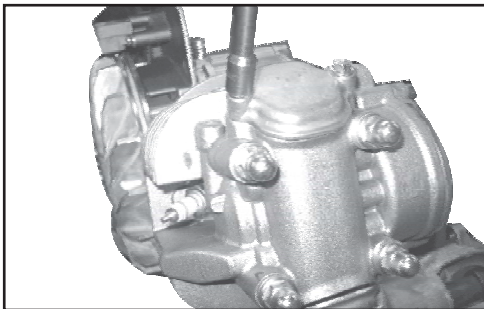

Fig. D

## CYLINDER / PISTON

### INDEX

	PAGE No.
GENERAL SERVICE DETAILS	97
REMOVAL OF CYLINDER	98
REMOVAL OF PISTON	100
INSTALLATION OF PISTON	102
INSTALLATION OF CYLINDER	103

### GENERAL SERVICE DETAILS

This part deals with the servicing of cylinder block and piston assembly.

Care to be taken, to prevent the parts from getting damaged.

Engine must be removed from the chassis for the service of cylinder block and piston assembly.

Carbon deposits present on the top of the cylinder must be cleaned out.

All the disassembled parts must be cleaned with cleaning solvent and then dried by compressed air before inspection.

### SPECIFICATIONS

ITEM		STANDARD			SERVICE LIMIT
		B	C	D	
Cylinder (BCD grades only)					
	Cylinder Bore	57.020 - 57.025 mm	57.015 - 57.020 mm	57.010 - 57.015 mm	57.10
Piston	Piston O.D	56.985 - 56.980 mm	56.980 - 56.975 mm	56.975 - 56.970 mm	56.90
	Cylinder-to-piston clearance	0.035 - 0.045 mm	0.035 - 0.045 mm	0.035 - 0.045 mm	0.09 mm
	Piston pin hole I.D	14.003 - 14.009 mm			14.021
Piston pin	Piston pin O.D	13.996 - 14.000 mm			13.983
Piston ring	Piston ring-to-groove	Top	0.015 - 0.05 mm		0.08
		Second	0.015 - 0.045 mm		0.08
	Piston ring end gap	Top Ring	0.15 - 0.30 mm		0.45
		Second Ring	0.30 - 0.45 mm		0.45
		Oil (Side rail)	0.20 - 0.70 mm		1.1

## CYLINDER PISTON

### CYLINDER BLOCK

#### REMOVAL

Remove silent chain, idler gear, pinion gear see Page 117 & 118.

Remove cylinder head assy. Page 104.

Remove cylinder block by sliding up.

Fig. A.

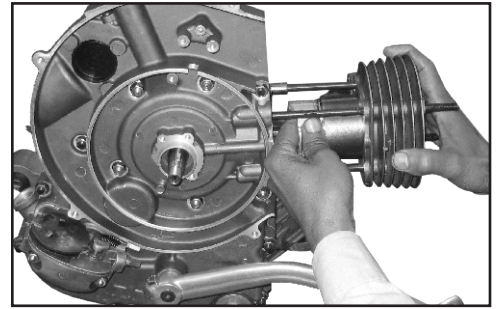

Fig. A

Take care that in process of cylinder removal, piston assembly does not hit crank case.

Fig. B.

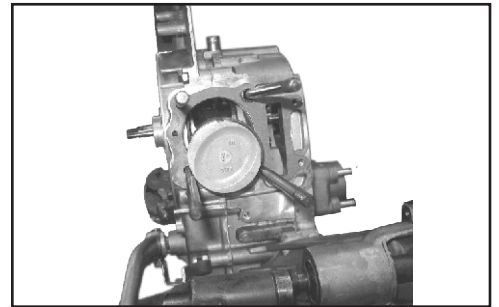

Fig. B

Remove piston assy. see Page 100-A of the manual.

Remove gasket and 2 nos. of dowel pins 'C'.

Fig. C

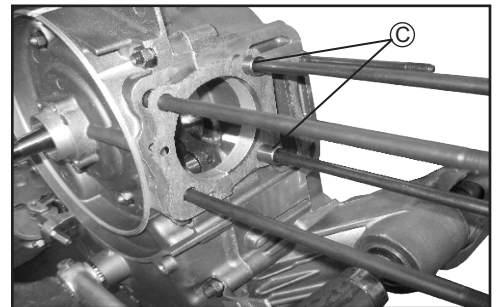

Fig. C

Remove crank case studs - 4 nos. + 2 nos., if required.

Fig. D

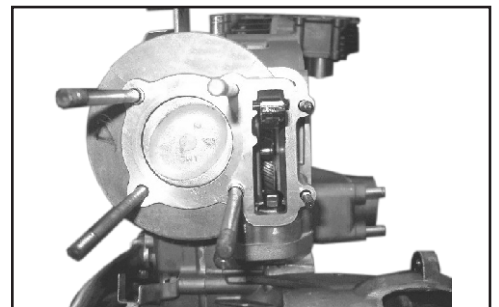

Fig. D

Clean mating surface thoroughly with care not to create scratches on it.

Fig. E.



Fig. E

## CYLINDER PISTON

### INSPECTION

Inspect cylinder bore for scratch in the bore.

Measure ID of cylinder bore at 3 locations and measure maximum dia.

Service limit - **57.10**

Calculate cylinder to piston clearance.

Service limit - **0.09**

Calculate taper and ovality

Measure cylinder bore as shown in sketch

Service limit -

Taper - **0.05 mm**

Ovality - **0.05 mm**

Check at top of cylinder for warpage with the help of feeler gauge and straight edge.

Service limit - **0.05 mm.**

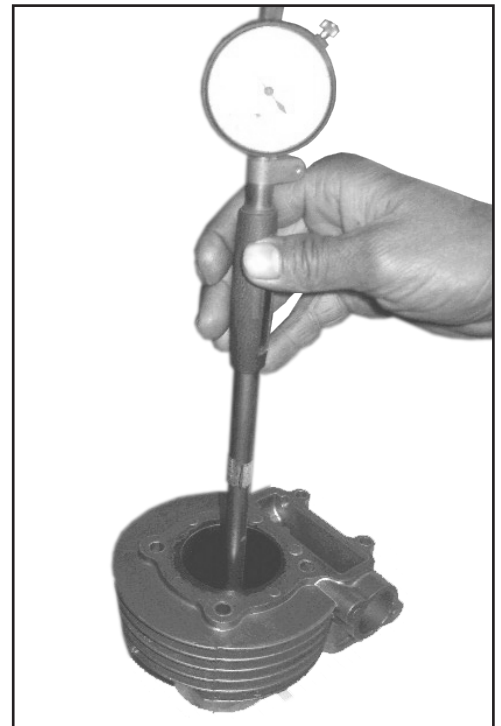

Fig. A

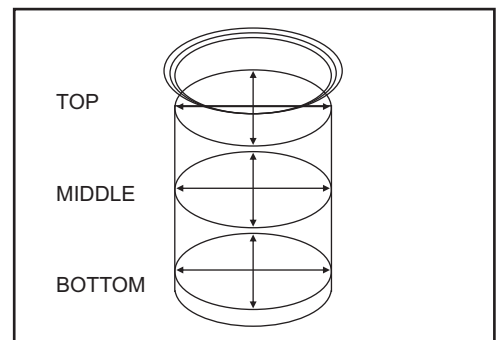

Fig. B

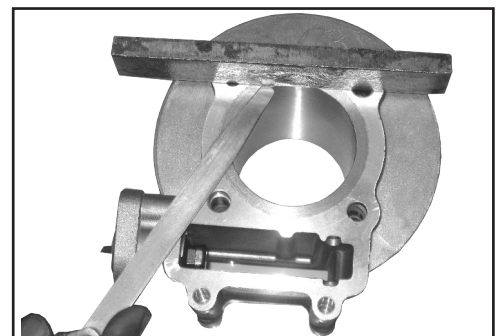

Fig. C

## CYLINDER PISTON

### PISTON

#### REMOVAL

Remove piston pin clips by plier.

Push piston pin out of connecting rod and piston, using Tool No. **H-3391516**

Fig. A.

Remove piston taking care that connecting rod does not hit crank case.

Close crank case opening to avoid dust entry.

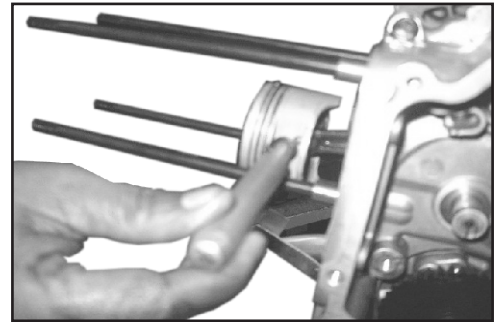

Fig. A

Open gap end of piston rings by thumb pressure and slide out all the rings. Avoid too much opening of rings and take care that no scratches are formed on piston.

Clear carbon deposits on piston crown, piston ring grooves using a rejected piston ring.

Do not use wire brush.

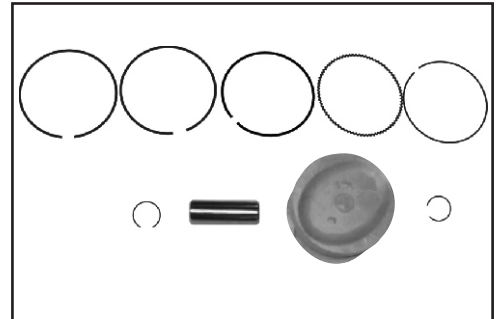

Fig. B

#### INSPECTION

Check for free rotation of piston rings in respective grooves.

Place ring into bottom of cylinder in horizontal level (Not at angle) and measure gap between two ends of the ring.

Fig. C.

Service limit -

Top ring	-	<b>0.45 mm</b>
Second ring	-	<b>0.45 mm</b>

Close piston rings and press into groove so that OD of rings is matching with piston OD and measure gap between ring surface to piston groove surface.

Top ring	-	<b>0.08 mm</b>
Second ring	-	<b>0.08 mm</b>

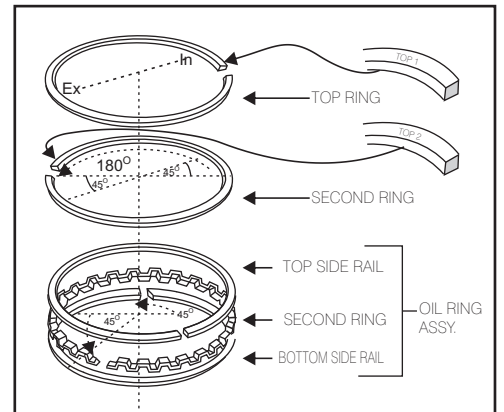

Fig. C

## CYLINDER PISTON

Measure piston OD at 90° to piston pin axis at a point 10 mm, above the piston skirt bottom edge.

Service limit - **56.90 mm**



Fig. A

Measure the piston pin hole ID at 'X' and 'Y' direction take maximum reading to determine ID.

Service limit - **14.021 mm**

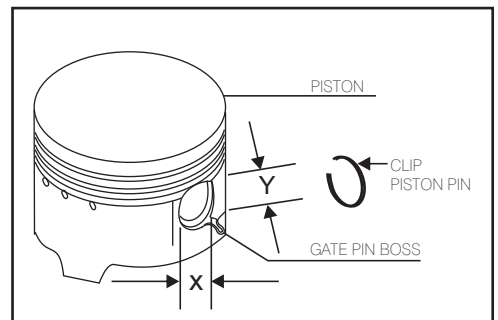

Fig. B

Measure piston pin OD at 3 points in 2/3 directions of circumference using micrometer.

Service limit - **13.983 mm**

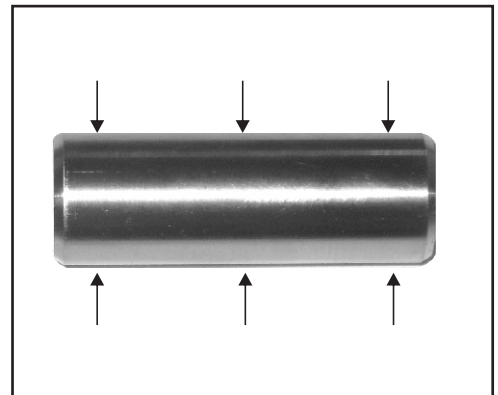

Fig. C

Calculate piston pin to piston pin bore clearance.

Service limit - **0.02 mm.**

Measure the connecting rod small end ID.

Service limit - **14.023 mm**

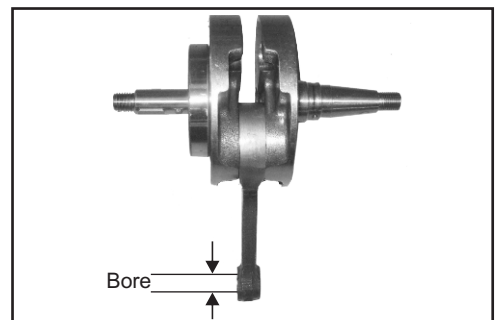

Fig. D

## CYLINDER PISTON

Calculate connecting rod to piston pin clearance.

Service limit - **0.035 mm.**

### PISTON INSTALLATION

Lubricate rings and piston ring grooves by engine oil and fit piston rings carefully.  
Fig. B.

To fill oil ring first fit the spacer and then the side rails.  
Fig. C.

Rotate rings to arrange ring gaps & fit circlip on one side as shown in the figure.

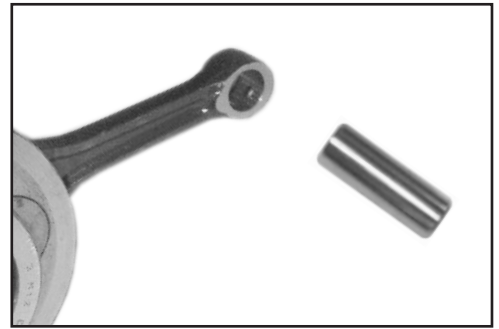

Fig. A

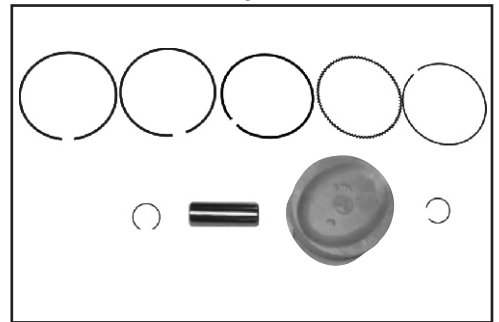

Fig. B

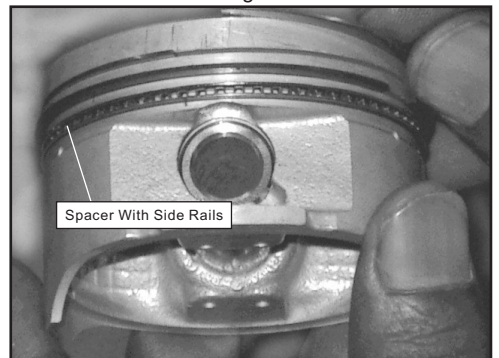

Fig. C

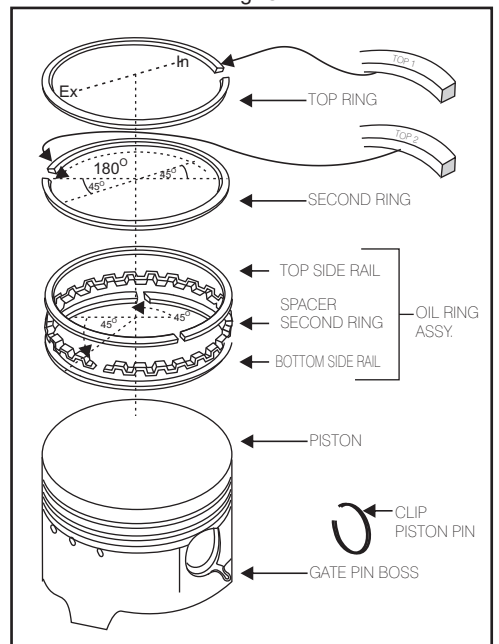

Fig. D



## CYLINDER PISTON

Lubricate piston pin and bore in the piston and small end of connecting rod.

Fit piston pin keeping 'IN' mark of piston towards inlet into piston bore through small end of connecting rod.  
Fig. A.

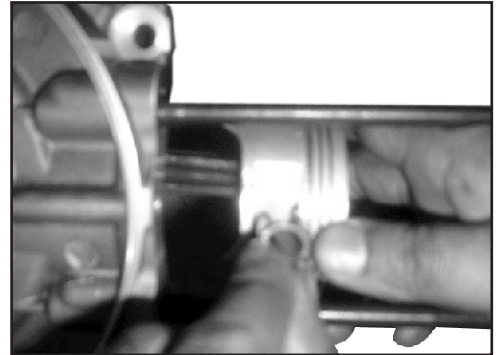

Fig. A

Fit second clip in the grooves of piston pin hole.

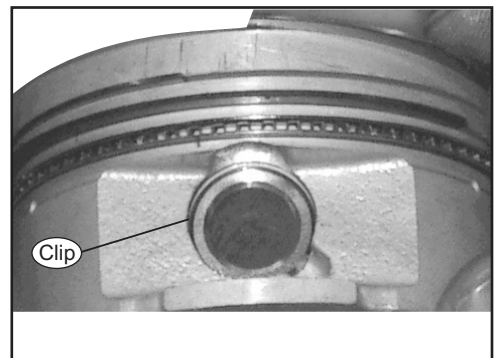

Fig. B

### CYLINDER INSTALLATION

While fitting these studs please take care that the length of studs outside of crank case to top point of stud, is within specified limits.

Crank case studs for cap nuts 4 nos. - **170.0 mm.**

Crank case studs, for holding block and cylinder 2 numbers - **83 mm.**

Fit dowel pins and new gasket.

Lubricate cylinder bore walls, piston and rings.  
Fig. C.

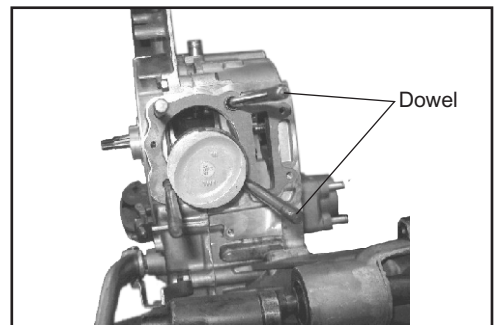

Fig. C

Fit cylinder on piston by pressing piston rings and inserting into the bore by figures.

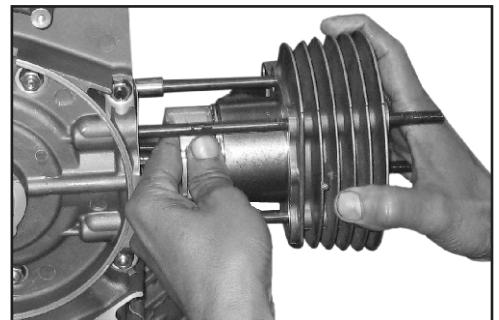

Fig. D

## CYLINDER PISTON

---

Fit cylinder head gasket, dowels and cylinder head. Tighten cap nuts and nuts for holding cylinder head to cylinder block. Refer Page 93.

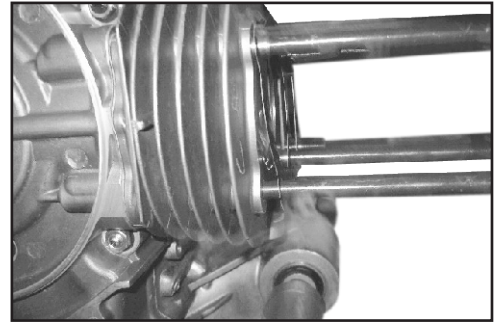

Fig. A

Pass the silent chain from the passage for it in cylinder block & cylinder head.

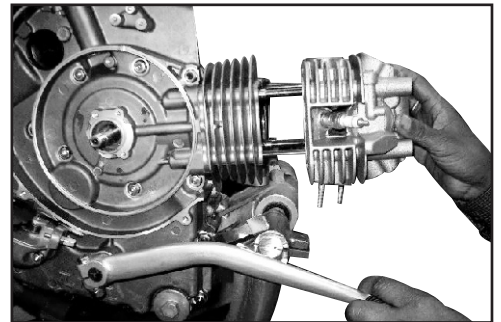

Fig. C

For other sub-assemblies see respective chapters.

---

# CLUTCH

## INDEX

	<b>PAGE No.</b>
GENERAL SERVICE DETAILS	105
CLUTCH COVER, PAPER FILTER ELEMENT, OUTER LEVER	106
CLUTCH ASSEMBLY	111
DRIVE PINION AND IDLER GEAR	116

## GENERAL SERVICE DETAILS

For the service of this part, there is no need to dismantle the engine from the frame.

Clutch must be thoroughly oiled.

All the plates and springs of the clutch must be made free from dust, dirt and then only reassembly should be done.

## SPECIFICATIONS

	<b>ITEM</b>	<b>STANDARD</b>	<b>SERVICE LIMIT</b>
Clutch	Lever free play	2.0 mm	
	Spring free length / No. of turn	+0.5 28.0 - 1.5 / 5.75 Turns	27.0mm
	Disk clutch friction thickness	3.0 ± 0.2	2.5 mm
		2.4 ± 0.15	2.0 mm
	Clutch bush	-0.050 O.D. 28.1 - 0.075	28.03mm
	Engine gear	+0.033 I.D. 28.1 + 0.00	28.18 mm
Driven plate warpage		0.15 mm	

## TORQUE VALVES

Clutch cover bolts / nut	-	<b>1 to 1.1 kg-m.</b>
Ring nut	-	<b>4.20 kg-m.</b>

## CLUTCH

### CLUTCH COVER

#### REMOVAL

Drain the engine oil in a clean container.  
Fig. A.

Remove the following :

Cowl (LH)  
Spare wheel  
Battery (if fitted)  
Rear Wheel

Loosen the clutch cable adjusting screw. Disconnect the cable from the outer lever, by opening clutch link bolt.  
Fig. B

Remove air filter by opening 3 flange bolts.

Remove lower bolt of rear shock absorber by opening its mounting nut.

Remove clutch cover by opening 4 flange bolts and one nut.  
Fig. C

(Caution: Loosen the bolt flange in a criss cross pattern in 2-3 steps.)

Remove the two dowel pins and packing.  
Fig. D.

(Caution: use only scrapper for packing material removal.)

Open three remaining nuts (M6-6H) and curved washers.

Remove the paper filter cover and packing.  
Fig. E & F.

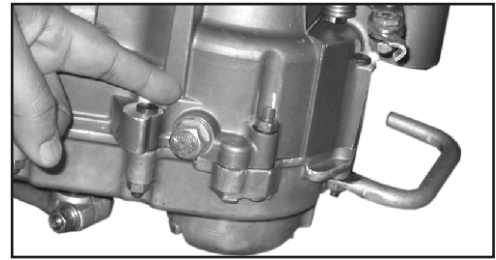

Fig. A

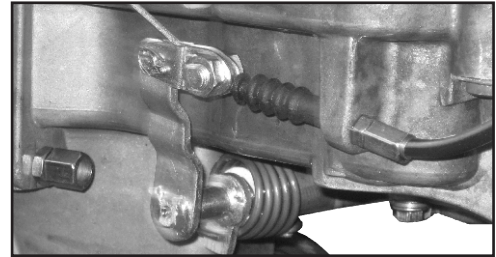

Fig. B

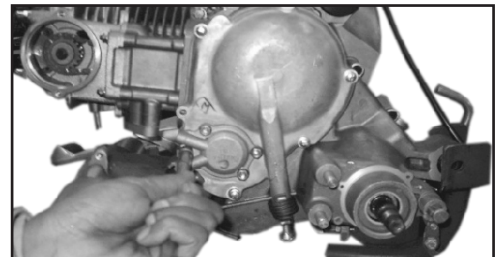

Fig. C

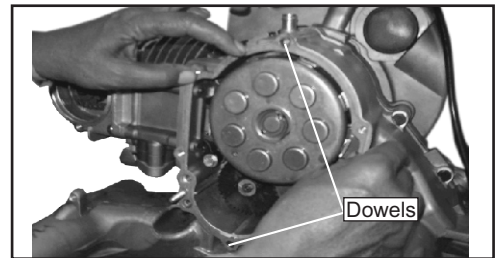

Fig. D

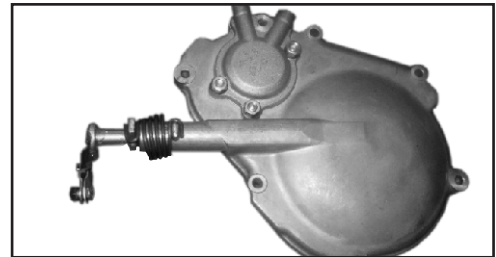

Fig. E

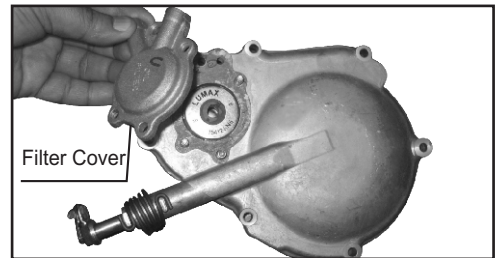

Fig. F

## CLUTCH

Remove the paper filter & spring below it.  
Fig.A

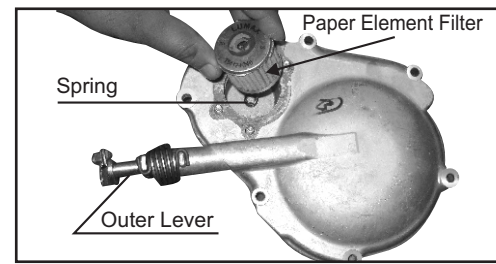

Fig. A

Remove the Actuating Pad.  
Fig. B



Fig. B

Open the outer lever spring.  
Fig. C

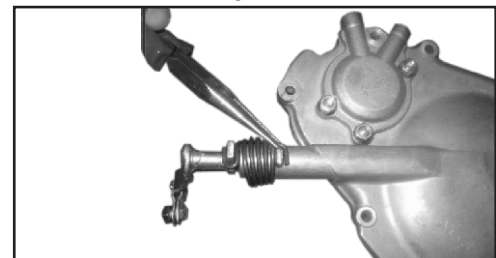

Fig. C

Take out inner lever, outer lever and spring.  
Fig. D & E

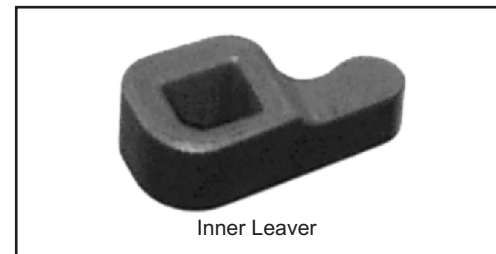

Fig. D



Fig. E

Take out 2 no. 'O' rings from outer lever.  
Fig. F

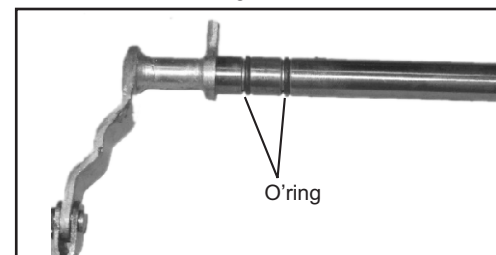

Fig. F

# CLUTCH

## INSPECTION

Inspect the mating surface for cuts and damages and remains of gasket, on clutch cover and crank case.  
Fig. A.

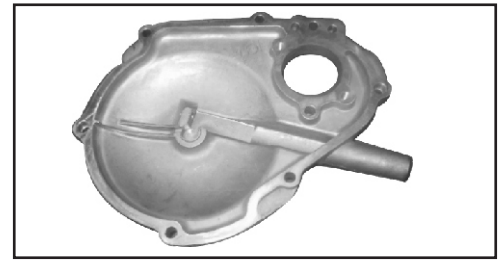

Fig. A

Inspect the mating surface for 'cover paper filter element' for cuts or damages and also on clutch cover.  
Fig. B.

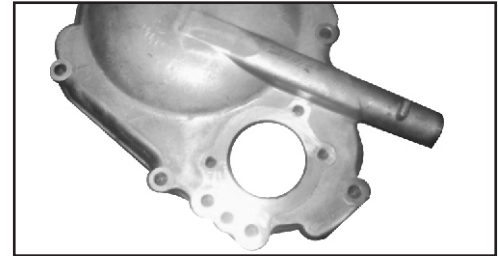

Fig. B

Inspect the oil passage by blowing compressed air in clutch cover and filter cover.  
Fig. C.

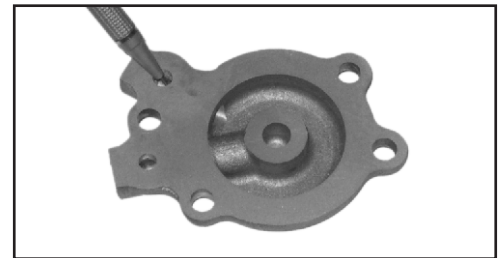

Fig. C

Inspect the outer lever, actuating pad & inner lever for wear. Replace, if required.  
Fig. D.

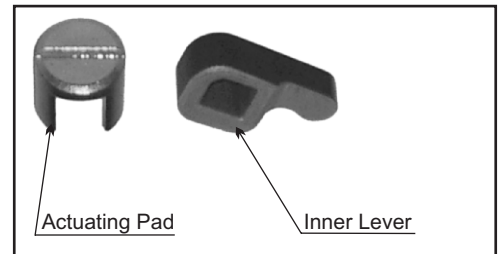

Fig. D

Check play between bore for outer lever in clutch cover and outer lever. Replace, if required.  
Fig. E.

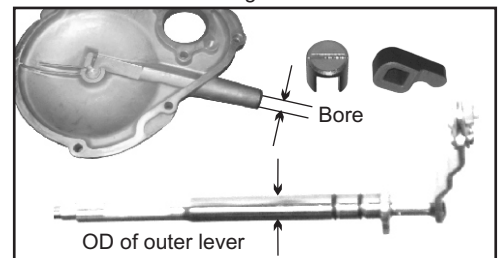

Fig. E

**INSTALLATION**

Clean filter cover by solvent and blow dry by compressed air.  
Fit the spring of element oil filter properly in its housing.  
Fig. A.

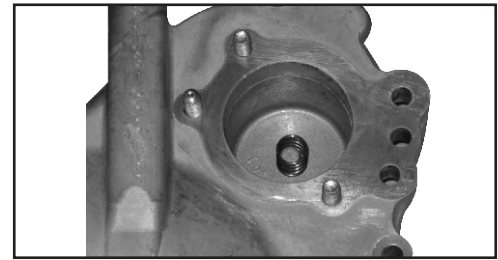

Fig. A

Fit the element oil filter in correct direction.  
Fig. B

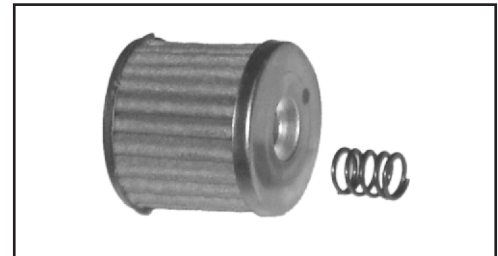

Fig. B

Apply oil to the mating surface and fit new gasket for oil filter cover.  
Fig. C.



Fig. C

Fit the oil filter cover with the help of three curved washers and nuts.  
Fig. D.

(Note: Fourth nut to be fitted when clutch cover assembly is installed on crank case.)

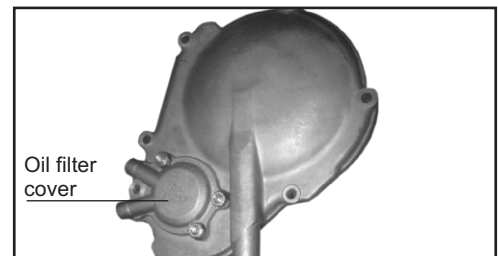

Fig. D

Lubricate outer lever and install torsion spring and two nos. of new 'O' rings on it.  
Fig. E.

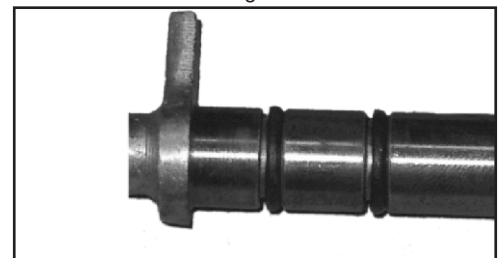

Fig. E

Fit the inner lever in to the housing provided for it in clutch cover with the help of grease.

Insert the outer lever in clutch cover in correct position of inner lever. Fit actuating pad in its housing above the inner lever. Fit hook of spring to clutch cover lug.  
Fig. F.

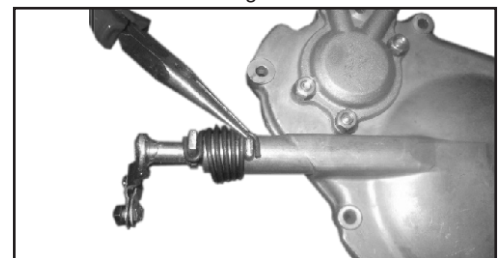

Fig. F

## CLUTCH

Check the operation of actuating pad by rotating outer lever, before assembly of clutch cover.  
Fig. A.

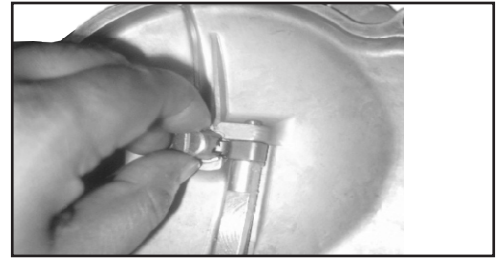

Fig. A

Fit the two dowel pins and new packing with little oil on clutch cover.  
Fig. B.

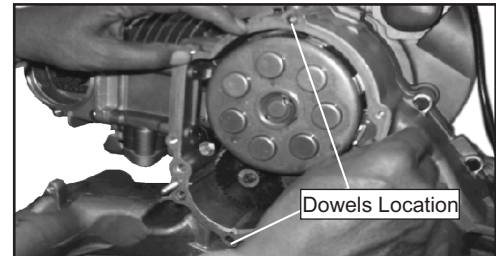

Fig. B

Fit the clutch cover with the help of 4 bolts and one nut.  
Fig. C.

Tightening Torque – **1 to 1.1 kg-m.**

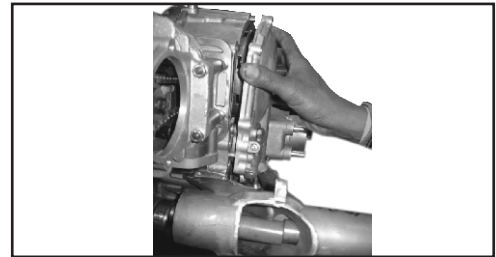

Fig. C

Fit air filter assy. with the help of 3 screws.

Fit rear shock absorber with mounting bolt and nut.

Tightening Torque – **3.0 to 3.5 kg-m.**

Fig. D.

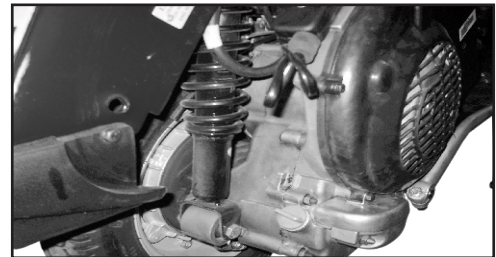

Fig. D

Tighten the clutch cable by lock nut and then with adjuster screw adjust free play of 2 mm. at clutch lever of handle bar.  
Fig. E & F.

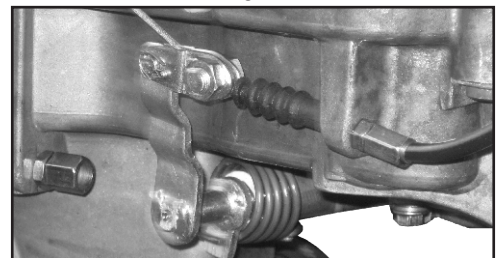

Fig. E

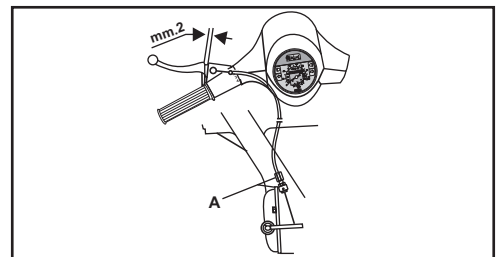

Fig. F



**CLUTCH ASSEMBLY**

**REMOVAL**

Open retainer spring by lifting and remove pressure plate, from clutch box.

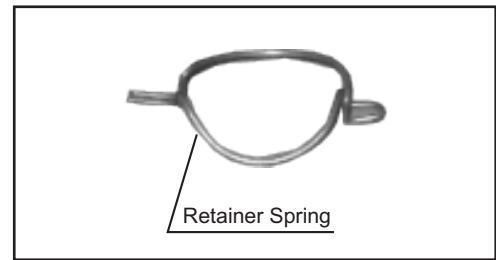
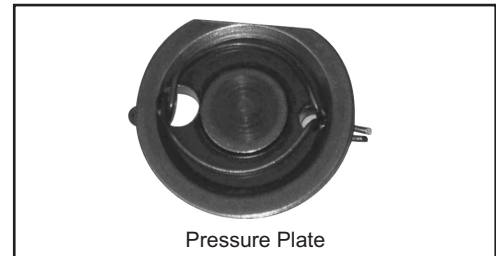

Fig. A



Pressure Plate

Fig. B

Open the lock washer and arrest the clutch assembly to crank case with the help of special Tool No. **H-3391517**. Open ring nut with the help of special Tool No **H-3391515**.  
Fig. C.

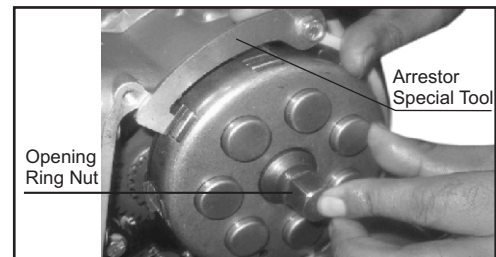

Fig. C



Ring Nut

Fig. D

Take out ring nut, lock washer and clutch assembly.  
Fig. D & E.



Lock Washer

Fig. E

Compress the clutch assembly by using Tool No. **H-1391524**

Take out the circlip by lifting one end first.  
Fig. F.

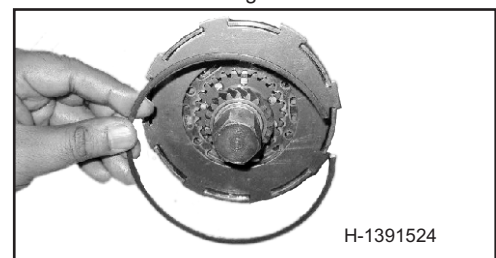

H-1391524

Fig. F

## CLUTCH

Release the tool and take out drive / driven plates.  
Fig. A & B.

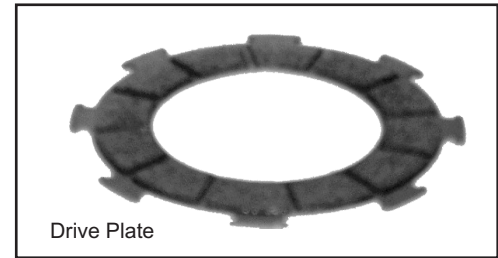

Fig. A

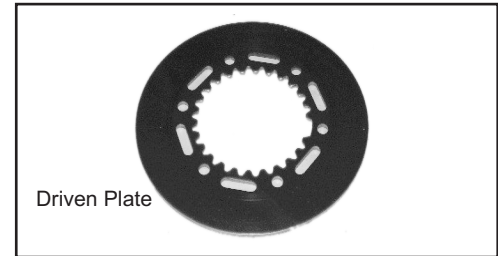

Fig. B

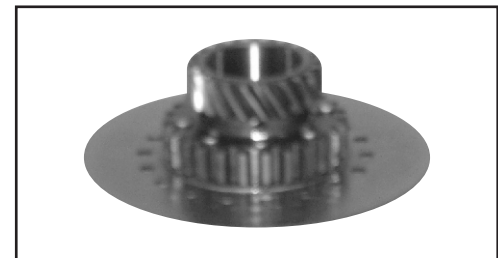

Fig. C

Take out engine gear assembly, clutch bush assembly  
from clutch housing.  
Fig. C & D.



Fig. D

Take out springs and caps.  
Fig. E.

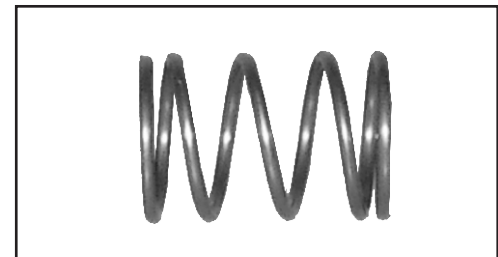

Fig. E

### INSPECTION

Inspect the ring nut & lock washer for damage and  
replace if required. Fig. D and E of Page 111.

Inspect the spring for fatigue and free length.  
Fig. E.

Service Limit - **27.0 mm**

Inspect the pressure plate for wear.  
Fig. F.



Fig. F

Inspect the retainer spring for fatigue / spring action and bend.  
Fig. A.

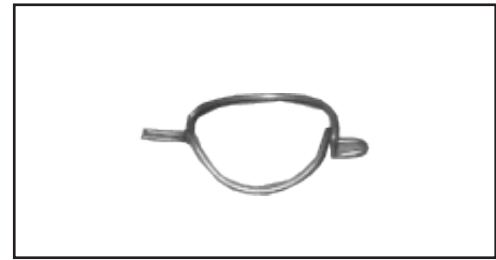

Fig. A

Inspect the driven plates for scoring mark, wear out and warpage. Check by keeping it on flat surface with the help of feeler gauge.  
Fig. B.

Service limit - **0.15mm.**

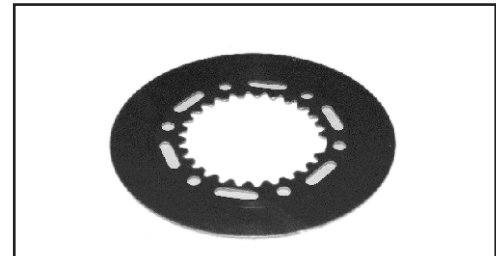

Fig. B

Inspect the drive plates for friction material wear damages and discolouring.  
Fig. C.

Service limit - **2.5 mm. (Both side friction material)**  
- **2.0 mm. (One side friction material)**

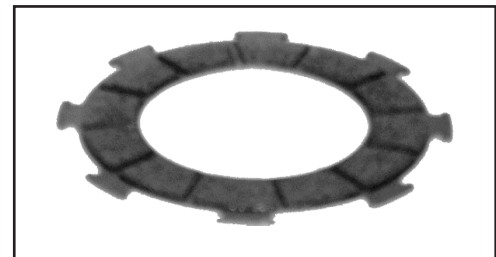

Fig. C

Inspect engine gear assembly for scoring marks, teeth wear bore wear and rivets looseness. Replace, if necessary.  
Fig. D.

Service limit - **28.18 mm. (Bore)**

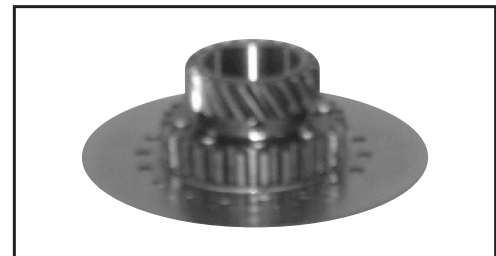

Fig. D

Inspect clutch bush assy. for scoring marks and out side diameter wear or damage. Replace, if necessary.  
Fig. E.

Service limit - **28.03 mm. (OD)**



Fig. E

Inspect the clutch case (box) for scoring marks and damages to the slots (housing for drive plates). Replace, if required  
Fig. F.

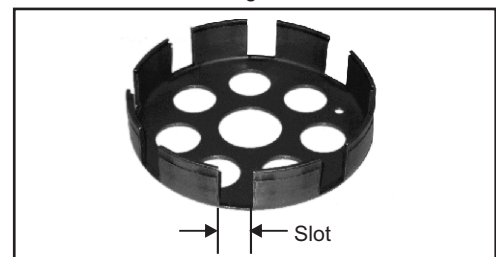

Fig. F

# CLUTCH

## INSTALLATION

Fit the seven caps and springs on clutch case box and clutch bush assy.

Fix the Tool No. **H-1391524** and compress the springs between clutch case box and clutch bush assembly by tightening the nut 'A'.

Fig. B.

### NOTE :

Ensure that upper end of spring is located in the spring seat provided in the clutch bush assy. Fig. C.

Fix engine gear assembly.

Fig. D.

Fit drive and driven plates in sequence as shown in sketch.

Fig. E

Fit the circlip in clutch box groove.

Fig. F.

### NOTE :

Both ends of circlip must be fixed in the groove of the clutch bell and open ends are not to be located in slot area. It is to be located against wall area of clutch box. Fig. B.

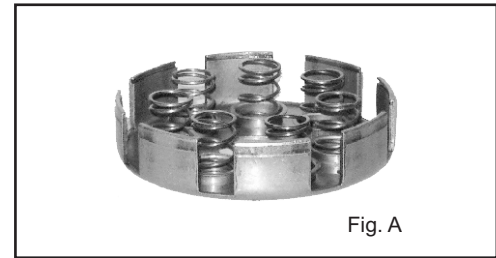

Fig. A

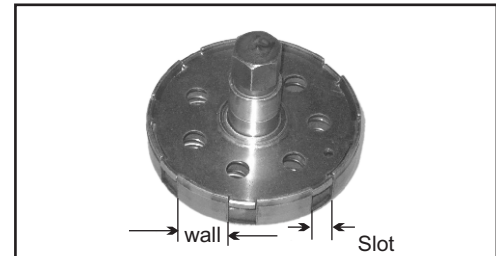

Fig. B

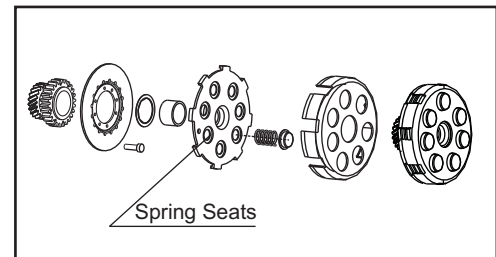

Fig. C

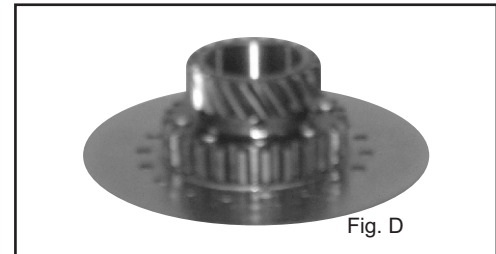

Fig. D

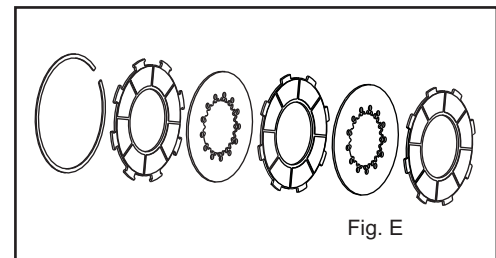

Fig. E

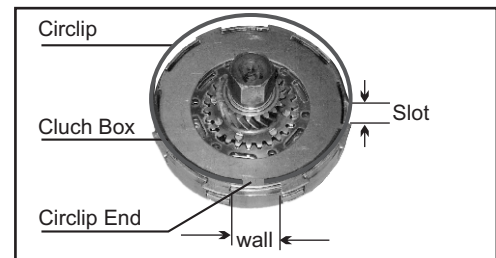

Fig. F

Fit the key and clutch assembly aligning with the key.  
Fig. A.

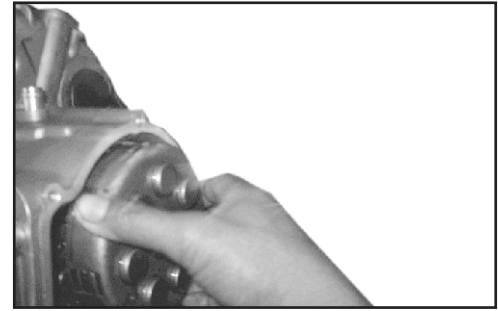

Fig. A

Fit the Arrester Tool No. **H – 3391517**.

Fit the lock washer, ring nut and tighten the ring nut  
with the help of special Tool No. **H – 3391515**.  
Fig. B.

Tightening Torque - **4.20 kg-m.**

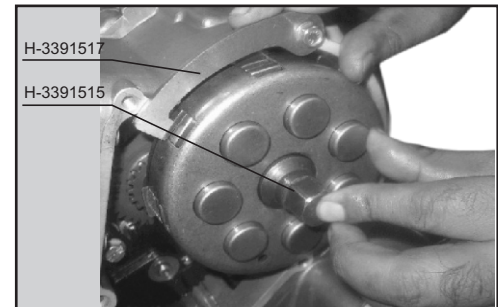

Fig. B

Bend the lock washer and lock.

Fit pressure plate with the help of retainer on clutch  
box.

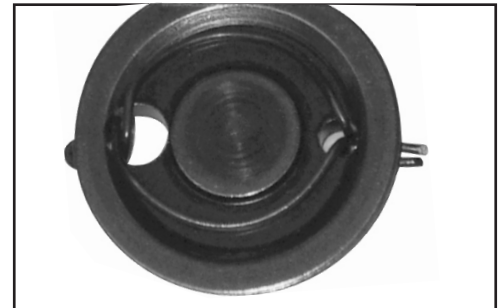

Fig. C

Fit gasket, dowels and clutch cover assembly with bolts  
and nut. Page 110.

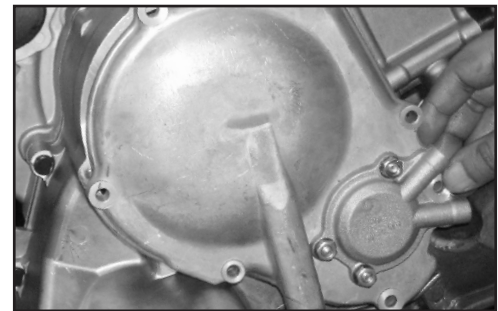

Fig. D

Fit the clutch cable. Page 110.

# CLUTCH

## DRIVE PINION AND IDLER GEAR ASSEMBLY

Pinion drive is fitted on crank shaft below the clutch assembly and gives drive to idler gear.

Idler gear is intermediate assembly between drive pinion on crank shaft and cam sprocket for timing chain and also gives drive to oil pump assy.

Pinion to idler gear revolution per minute are reduced, and in reverse direction.

It is a composite part having one gear on one flange which gets drive from drive pinion and sprocket for timing chain, on other flange. A needle roller bearing is fitted in the bore.

Fig. C.

### REMOVAL

Remove clutch assy. and key. Page 111.

Remove washer, pinion drive, shoulder washer and roller.  
Fig. D.

Operate lifter centre screw clockwise to slacken silent chain.

Fig. E.

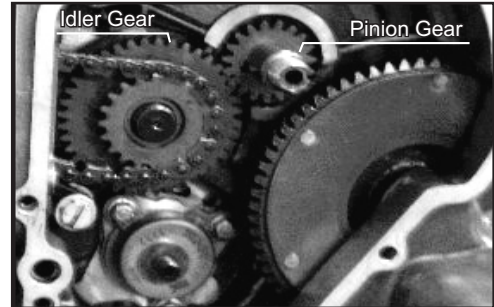

Fig. A



Fig. B

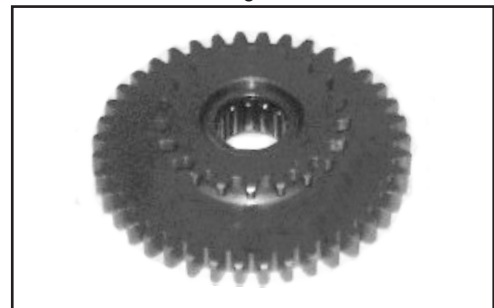

Fig. C

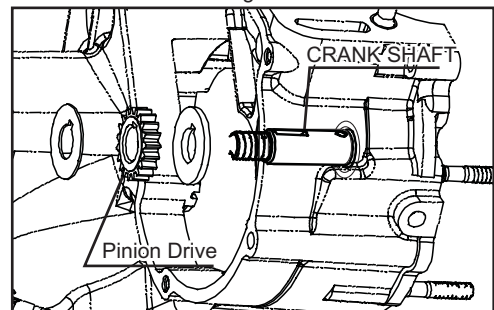

Fig. D

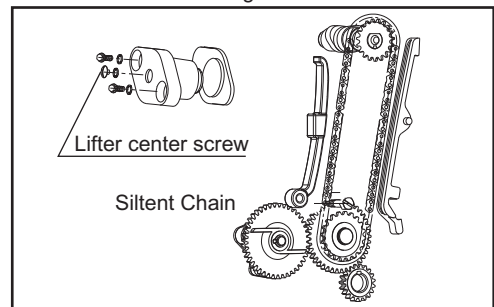

Fig. E

Remove cam sprocket bolt, sprocket and bush.

Remove silent chain.

Fig. A.

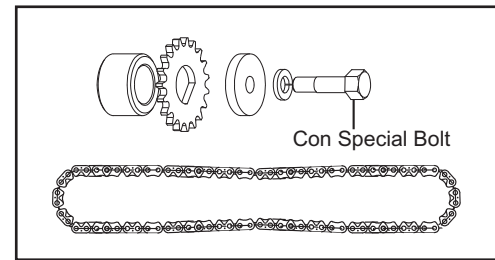

Fig. A

Remove circlip from pin for idler gear by nose plier.

Fig. B.



Fig. B

Remove idler gear assy. alongwith washer and wave washer. (Pin for idler gear is not to be removed).

Fig. C.

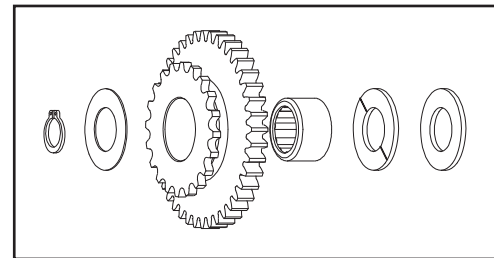

Fig. C

Take out needle roller bearing by using special Tool No. **H-3391556**.

Fig. D.

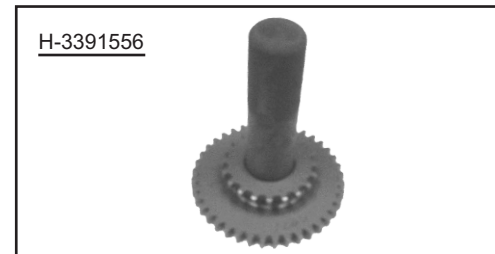

Fig. D

**INSPECTION**

Clean all parts by solvent and dry by compressed air.

Check pinion drive, idler gear teeth and sprocket for wear and damage, and replace as a set, if required.

Check for play and damage in needle roller bearing. Replace, if required.

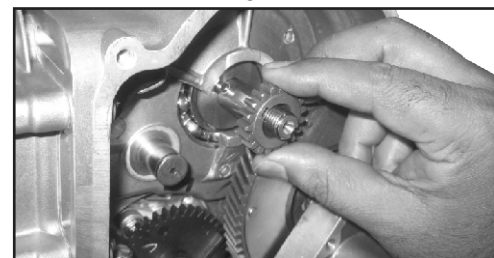

Fig. E

**NOTE:**

Drive pinion and idler gear are to be replaced in set only.

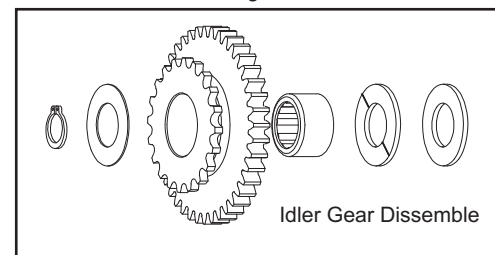

Fig. F

## CLUTCH

### INSTALLATION

Clean all the parts and dry by blown air.

Fit roller, shoulder washer, pinion drive and washer on crank shaft.

Fig. A.

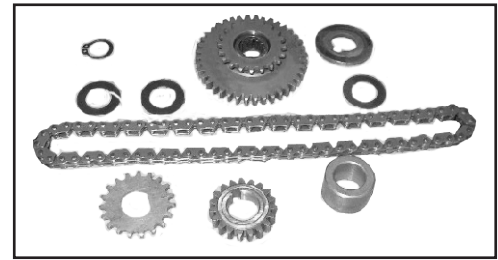

Fig. A

Lubricate needle roller bearing and fit into idler gear with the help of special Tool No. **H-3391557**.

Fig. B.

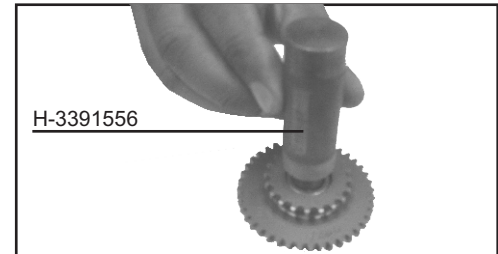

Fig. B

Fit washer, wave washer and idler gear washer and circlip. Ensure that the teeth of pinion gear and pump gear are matching properly with idler gear.

Fig. C.

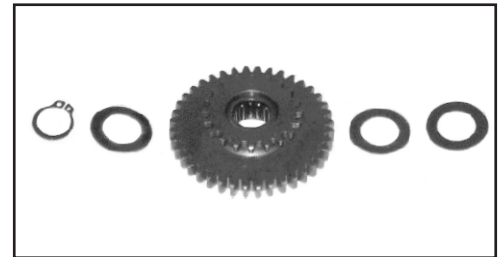

Fig. C

Match dot marks on pinion gear and dot marks on idler gear by lifting pinion gear and rotating it.

Fig. D.

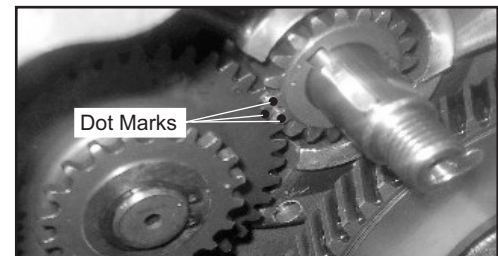

Fig. D

Fit silent chain, guide for chain tensioner silent chain and lifter tensioner assy. Keeping 'I' mark on cam sprocket in vertical top position with centre mark on cylinder head, keeping piston on T.D.C.

Tighten cam sprocket bolt.

Tightening Torque – **1.8 kg-m.**

Fit gasket, dowels and clutch cover with the help of bolts and nut. Page 110.

Tighten air filter screws.

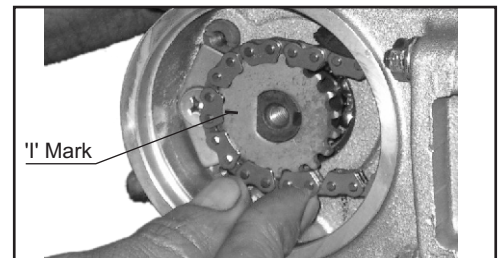

Fig. E



Fig. F



---

# MAGNETO ASSEMBLY

## INDEX

	<b>PAGE No.</b>
GENERAL SERVICE DETAILS	119
MAGNETO REMOVAL	120
MAGNETO INSTALLATION	121

## GENERAL SERVICE DETAILS

This section covers servicing of rotor, stator and magneto assembly for its removal and installation.

For pick-up coil and charging coil inspection, please refer Page no 32.

While servicing magneto assembly, keep ignition switch in off position.

## TORQUE VALUES

Tightening torque flywheel nut	- <b>6.5 kg-m.</b>
Stator plate screws	- <b>0.4 kg-m.</b>
Pick up and clamp plate	- <b>0.25 kg-m.</b>

## MAGNETO ASSEMBLY

### MAGNETO ASSEMBLY

#### REMOVAL

Disconnect Magneto wiring harness from LT socket.

Remove fan cover. Page 80.

Arrest rotor assembly with the help of locking tool for flywheel Tool No. **H-3391518**.

Fig. A.

Open magneto nut and take it out along with washer.

Fig. A.

Tool No. **H-3391519** is used for extraction of rotor. Fix tool to rotor and screw in the centre bolt of special tool till magneto rotor comes out.

Fig. B.

Take out rotor assembly.

Take out key for rotor assembly.

Open clamp plate for harness by opening its screw.

Fig. C.

Open pick-up coil by opening 2 screws.

Unscrew 3 screws and take out coil stack assembly.

Fig. D.

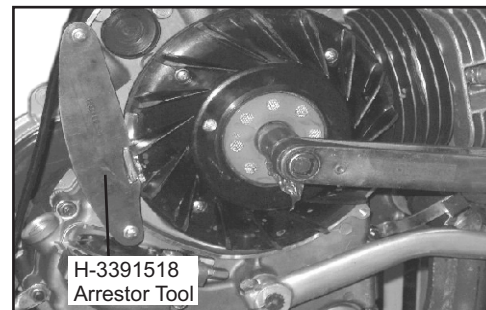

Fig. A

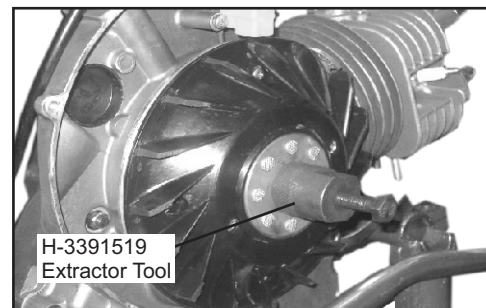

Fig. B

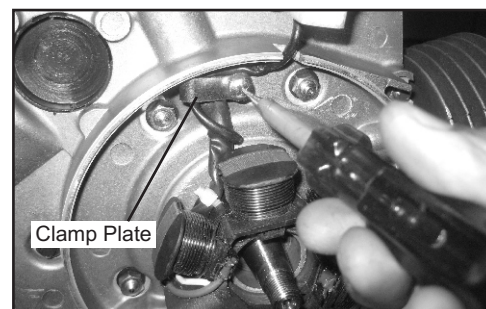

Fig. C

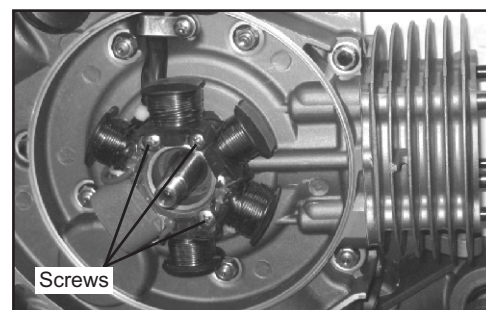

Fig. D

## MAGNETO ASSEMBLY

Take out magneto wiring harness from crankcase and take out the coil stack assembly.

Fig. A.



Fig. A

To remove charging coil use soldering iron to disconnect green and white wires. Open the lock of lamination and take out charging coil.

Fig. B.



Fig. B

### INSPECTION

Check rotor assembly for damages from inside and outside.

Fig. 'C'.

Check if rotor fan is damaged. Replace, if required.

Check coil stack assembly for damages / touching marks. Replace, if required.

Check charging coil and pick-up coil. Page 32

Check key of rotor assembly for damages.



Fig. C

### INSTALLATION

Fit charging coil in coil stack assembly and lock it by bending the lamination plate

Fig. D.

Solder white and green wire ends to respective positions.

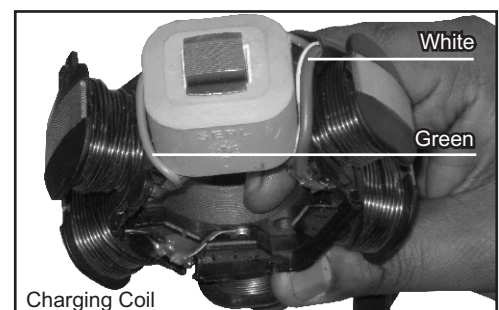

Fig. D

### NOTE:

While soldering take care that wires are properly closed and solder is clear and not touching any other wire.

## MAGNETO ASSEMBLY

Fit coil stack by tightening 3 screws in crankcase.

Fig. A.

Tightening Torque - **0.4 kg-m**

Fit pick-up coil with the help of 2 screws.

Fig. A.

Tightening Torque - **0.25 kg-m**

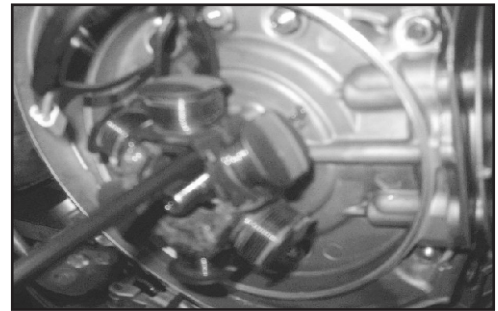

Fig. A

Fit clamp plate and hold the harness by screw.

Fig. B.

Install key for rotor and fit rotor aligning the passage.

Arrest flywheel rotor with the help of special Tool No. **H-3391518** and tighten it by putting lock washer and nut.

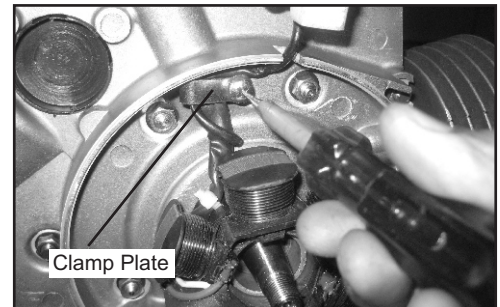

Fig. B

Tightening Torque - **6.5 kg-m**

Fig. 'C'

Check the gap between pick up unit and rotor. It should be **0.6 to 0.8 mm**.



Fig. C

### NOTE :

Loose connections may result in malfunctioning.

Connect the magneto harness with connector and main wiring harness.

---

# TRANSMISSION

## INDEX

	<b>PAGE No.</b>
GENERAL SERVICE DETAILS	123
GEAR CONTROL BRACKET AND KICK LEVER	124
CRANK CASE SEPARATION	128
STARTER SECTOR	129
DRIVE SHAFT ASSEMBLY	131
SPRING GEAR AND COUNTER SHAFT ASSEMBLY	136
CRANK SHAFT	138
BEARINGS REPLACEMENT IN CRANK CASE	141
CRANK CASE ASSEMBLY	145

### **GENERAL SERVICE DETAILS**

Engine must be removed from link assy. For servicing transmission sub-assemblies.

Crank case halves must be separated for servicing starter sector assy., drive shaft, counter shaft assy., crank shaft and bearings of crank case.

Following parts must be removed before separating crank case.

- Silencer, rear brake drum, air cleaner assy. and carburettor with insulator.
- Fan cover, cooling hoods, magneto assy.
- Clutch cover, clutch assy., pinion gear, silent chain, idler gear assy., cylinder head assy. and cylinder block.

In this chapter details are considering that all above sub-assemblies are earlier removed. Please see respective chapters for servicing these sub-assemblies.

All oil seals and gaskets are to be replaced with new while assembling crank case.

Avoid damage to crank case mating surface.

## TRANSMISSION

### GEAR CONTROL BRACKET AND KICK LEVER

#### REMOVAL

Remove kick by opening kick securing bolt / nut  
Fig. A.

Remove oil seal of kick.

Open gear selector bracket cover by opening bolt  
Fig. B.

Remove both gear control cables keeping handle in '0'  
position (NEUTRAL) by opening screw of cable nipples.  
Fig. C.

Open 2 nuts and curved washers to remove gear  
control bracket assembly from crank case.  
Fig. D.

Remove gasket for gear control bracket.

Remove 2 nos. dowels from crank case.  
Fig. E.

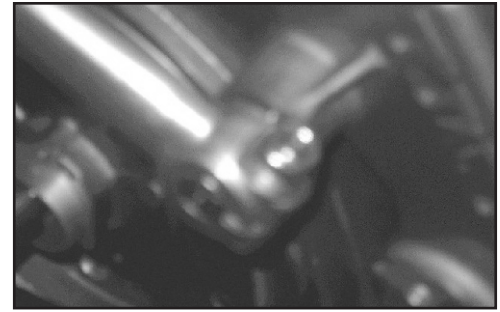

Fig. A

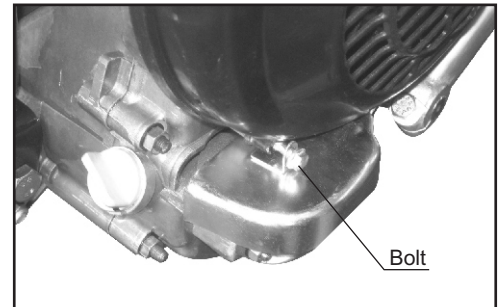

Fig. B

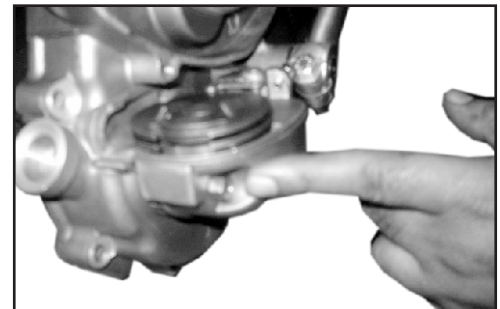

Fig. C

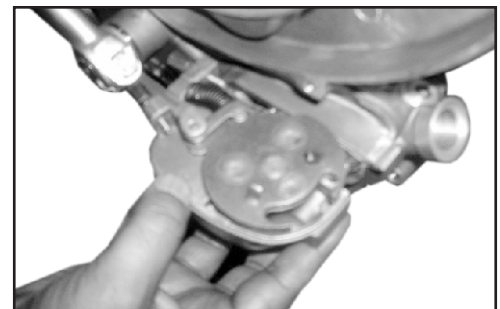

Fig. D

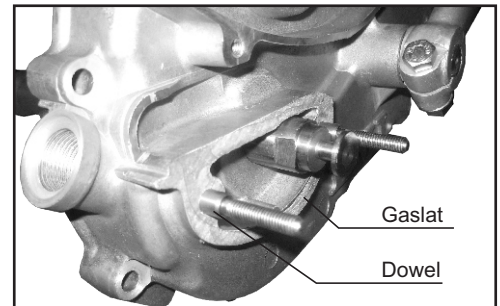

Fig. E

## INSPECTION

Check wear pattern on gear selector sector. If peaks of selector sector are rounded due to wear, replace gear control bracket assembly.

Check for play between axle for gear selector and bore of gear control bracket.

Check for wear pattern of sliding block.

Check for damages if any on roller assembly selector sector assembly and sliding block.

Check for fatigue / deformation of roller assembly spring.

If any of the above mentioned defect is present :

Gear control bracket will malfunction and assembly of gear control bracket is to be replaced.

Check for wear and deterioration of protective sleeve of kick lever. Replace, if required.

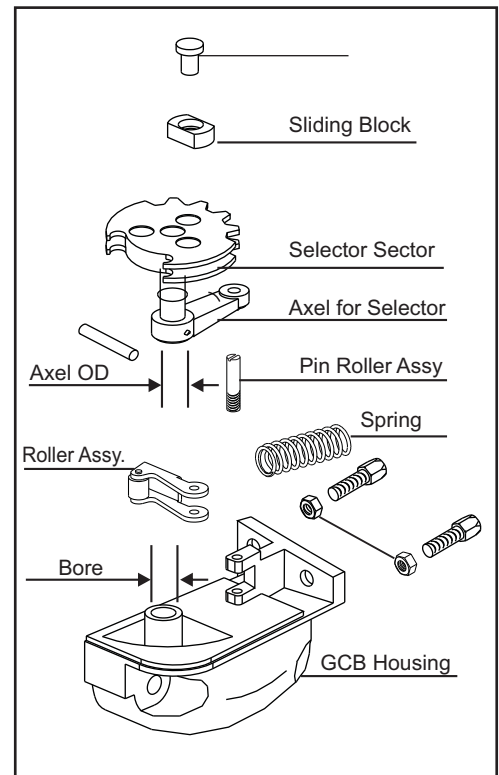

Fig. A

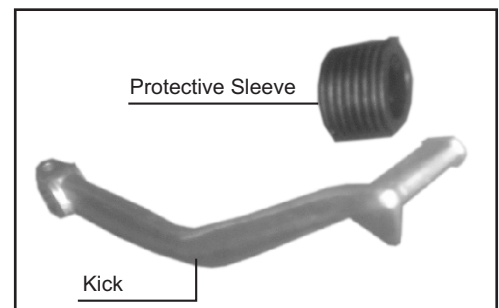

Fig. B

# TRANSMISSION

## INSTALLATION

Thoroughly clean all parts with solvent and blow dry with compressed air.

Lubricate roller assembly, selector sector assembly and sliding block.  
Fig. A.

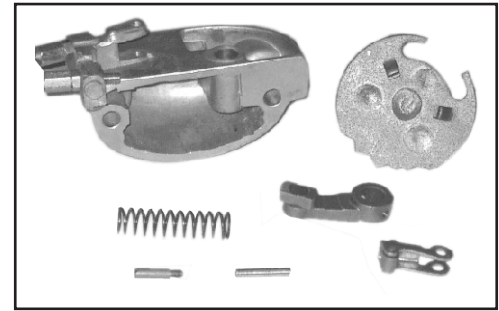

Fig. A

Apply grease on mating surface for gear control bracket and crankcase.

Fit gasket on crankcase.

Fit 2 nos. dowels on studs.  
Fig. B.

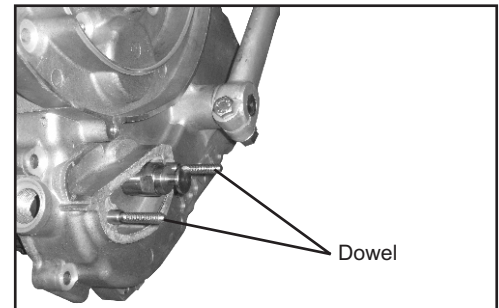

Fig. B

Fix gear control bracket assembly on crank case taking precaution that sliding block fits into the location for it in the gear control rod assembly.  
Fig. C.

Fit curved washer and tighten nuts.

Tightening Torque - **1.0 kg-m.**

Bring gear control lever bracket at handle bar at '0' position.

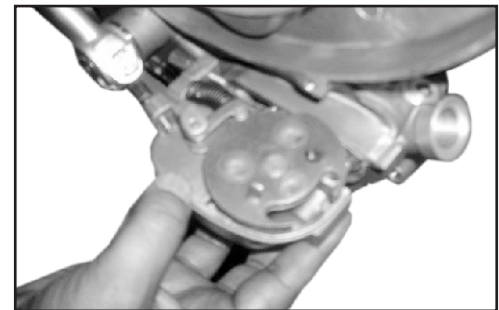

Fig. C

Fit gear control cables passing through adjusting screws and through the cables screw nipples. Cable is to be pulled by pliers and screw on nipple is to be tightened.

Take care cable is passed through the guide provided on the surface of selector sector.  
Fig. D.

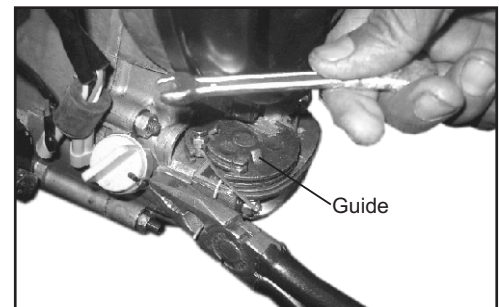

Fig. D



Check smooth operation of gear changing by operating gear changing sleeve on handle bar.  
Fig. A.

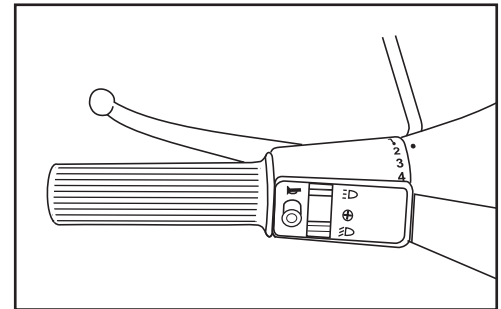

Fig. A

Take new oil seal for kick lever, apply oil on it and fit in the housing with Tool No. **H-3391555**.  
Fig. B.

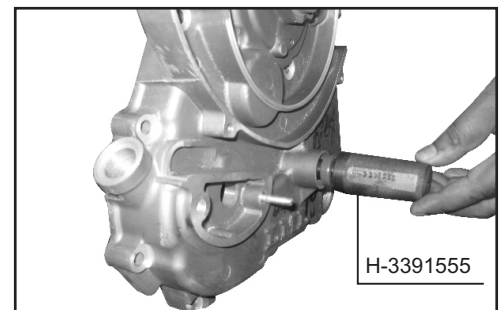

Fig. B

Fit kick lever with securing bolt, nut, plain and spring washer.

Tightening Torque            -    **2.5 kg-m.**

Check free operation of kick lever by hand 2/3 times and ensure.

Take small ride on scooter to check correct gear changing operation.

### ADJUSTMENT

If '0' mark is not at correct location for neutral position, adjust it by both gear control cables adjusting screws removing slackness in any of the cables.

In case if it is not adjusted loosen screws for cable nipples at the end hooked in gear selector sector. One is to be slackened and other is to be tightened to achieve correct position. Again tighten nipple screws fully after the adjustment is achieved.

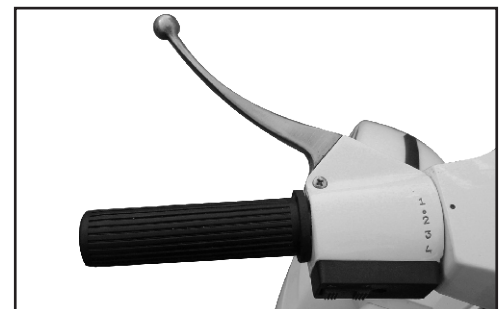

Fig. C

## TRANSMISSION

### CRANK CASE SEPARATION

Remove all control cables and electrical connections from engine.

Remove air bellow, carburettor and rear shock absorber. Remove link bolt from link assy. and take out engine from vehicle.

Following parts / sub-assemblies are to be removed before separating crank case halves :

Kick, fan cover, cooling hoods, silencer, carburettor, gear control bracket.

Clutch cover, clutch, pinion gear, idler gear, silent chain sprocket set.

Cylinder head, cylinder block, piston assy.

For removal of above sub-assemblies, please refer respective chapters.

Remove crank case bolts and nuts with curved washers.

Use special Tool No. **H - 3391520** for separating the crank case. Fit tool on fly wheel side, on the hub for crank shaft by 3 bolts and tighten the centre bolt till clutch side crank case and crank shaft assemblies get separated from fly wheel side crank case half.

Fig. A.

Take out dowels and gasket.

Fig. B.

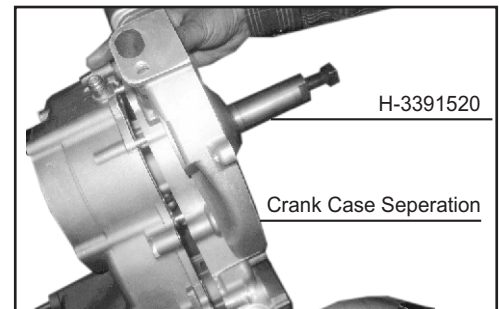

Fig. A

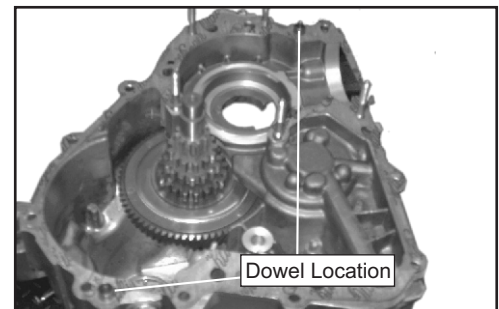

Fig. B

**STARTER SECTOR AND KICK SPRING**

**REMOVAL**

For removing starter sector and kick spring, separate crank case halves. See Page 128.

Starter sector and kick spring are fitted in fly wheel side crank case.

Remove starter sector assembly by pushing from outside end alongwith spring.

Remove starter gear and spring and thrust washer.

Remove kick return spring from sector assembly.

Remove buffers for starter sector 2 nos.

Fig. B.

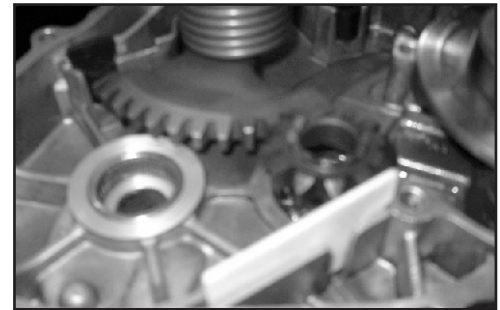

Fig. A

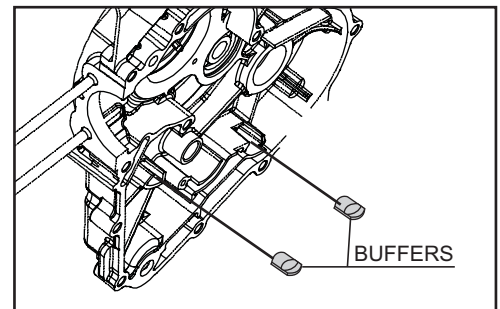

Fig. B

**INSPECTION**

Check the kick return spring for fatigue. Replace spring, if required.

Check the buffers for wear and damage.

Check straight end of spring for bend / damage. Replace, if required.

Check the slot of the cup in starter sector assembly for wear. Replace sector assembly, if required.

Check serrations on sector assembly for wear or rounding off. Replace sector assembly, if serrations are not good.

Check starter gear for wear.

Check spring for starter gear for fatigue.

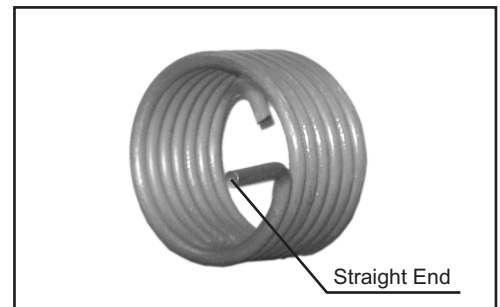

Fig. C

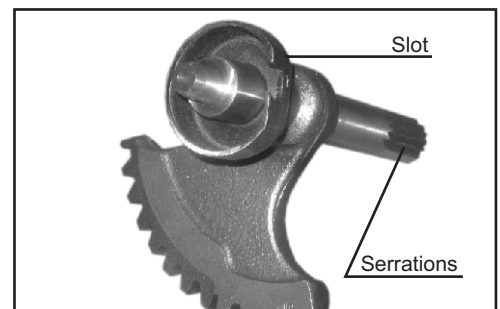

Fig. D

# TRANSMISSION

## INSTALLATION

Wash sector assembly / kick return spring / starter gear and spring for starter gear in solvent and blow dry with compressed air.

Install buffers 2 nos.

Install starter sector assembly into the bore in flywheel side crank case for kick assy.

Fig. A.

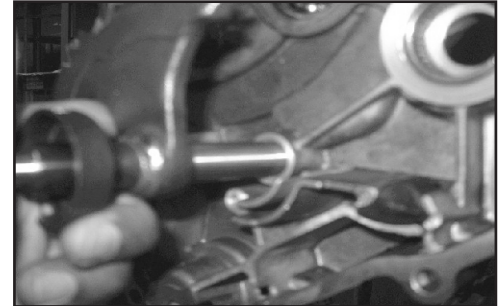

Fig. A

Fit one straight end of kick return spring into the locating hole provided in the crank case, and rotate anti-clockwise to install bent end of kick return spring into the slot provided for it in the cup of starter sector assembly.

Fig. B.

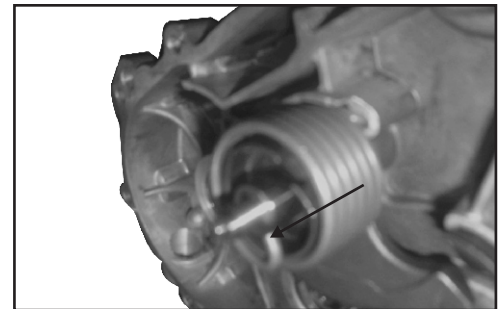

Fig. B

Fit oil seal and kick lever by using Tool No. **H-3391555**

Fig. C.

Operate kick 2 – 3 times by hand and ensure proper return of kick lever.

Install starter gear, spring for starter gear and thrust washer, on counter gear shaft.

Assemble flywheel side crankcase to clutch side crank case properly locating drive and spring gear assembly shafts by tightening bolts.

Fig. D.

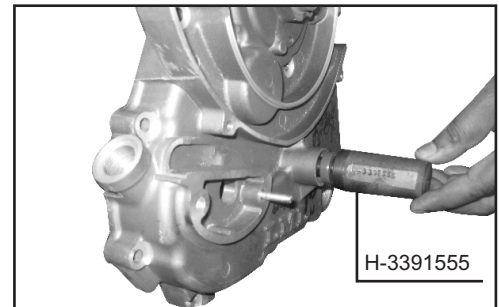

Fig. C

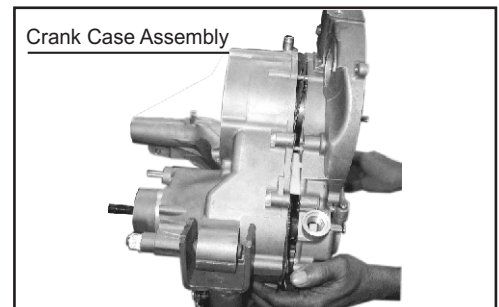

Fig. D

## DRIVE SHAFT ASSEMBLY

### DISSEMBLY

Separate crank case halves. Refer Page 139.

Remove drive shaft by using special Tool No. **H-2391522**.

Fig. A.

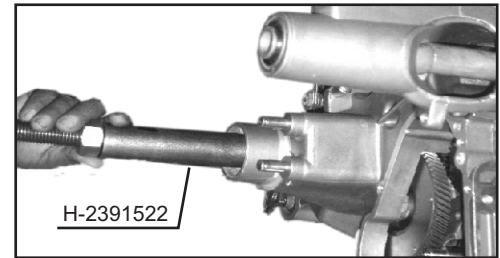

Fig. A

Remove circlip and shoulder washer.

Fig. B.

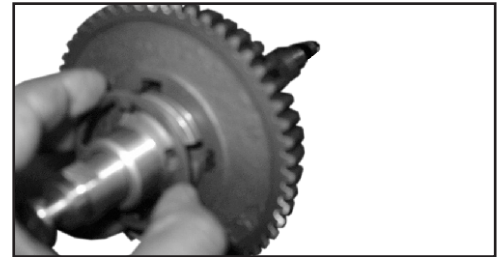

Fig. B

Remove speed gear (1<sup>st</sup>, 2<sup>nd</sup>, 3<sup>rd</sup> and 4<sup>th</sup>) from drive shaft  
Fig. C.

Remove shoulder washer and circlip using a plier (rear side).

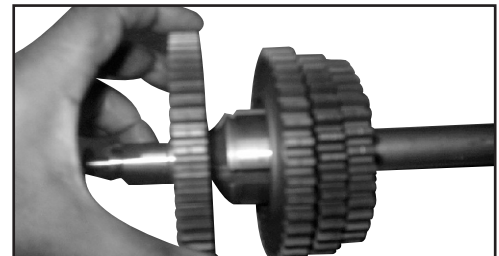

Fig. C

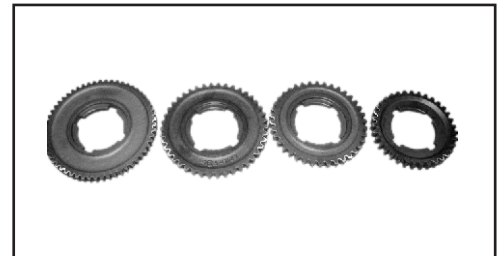

Fig. D

Remove gear control rod by spanner by holding drive shaft. To hold shaft insert plate into the slots. Left hand threads are provided for fitment of gear control rod into selector spider.

Fig. E.

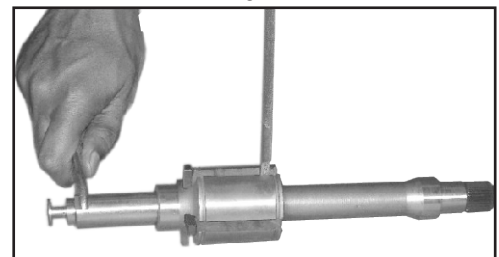

Fig. D

Remove selector spider from drive shaft assembly by rotating it to 90° and aligning with the slot provided for it.

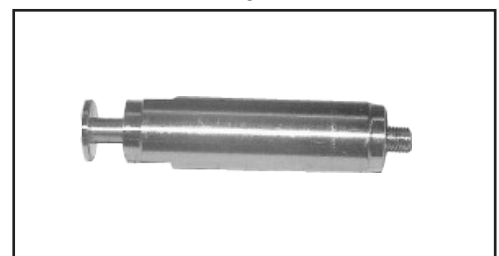

Fig. E

# TRANSMISSION

## INSPECTION

Wash all parts in solvent and blow dry by compressed air.

Fig. A.



Fig. A

Check the gears for teeth and slots provided for selector spider. Replace, if required.

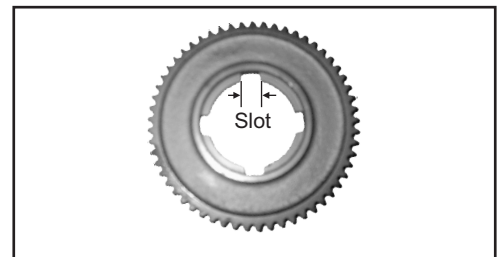

Fig. B

Check drive shaft bore for housing the gear control rod.

Service limit - **20.075 mm.**

Fig. C.

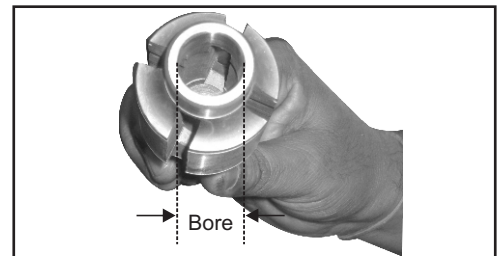

Fig. C

Check drive shaft for the damage to the slots and wear.

Check for drive shafts threads for damage.

Fig. D.

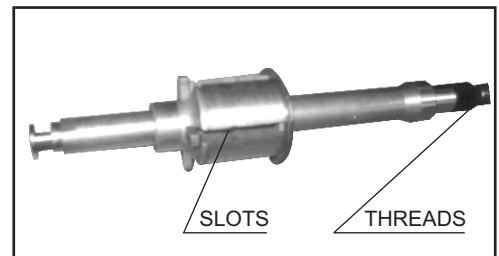

Fig. D

Check the OD of drive shafts for wear.

Fig. E.

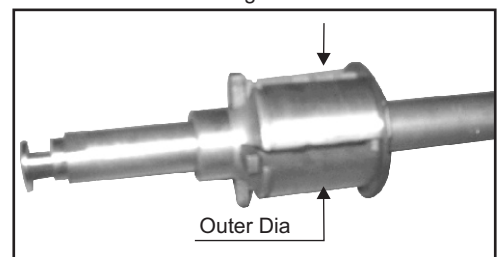

Fig. E

Check the ID of all four gears.

Fig. A.

Check for wear on OD of drive shaft and ID of speed gears. Replace, if excessive play is noticed.

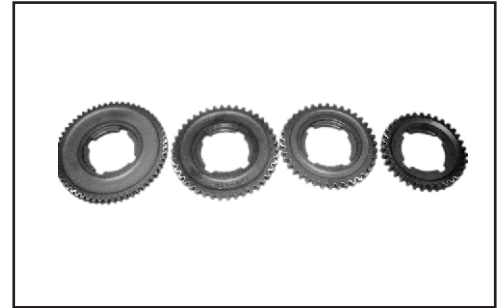

Fig.A

Check selector spider for wear and damage on its arms and threads.

Fig. B.

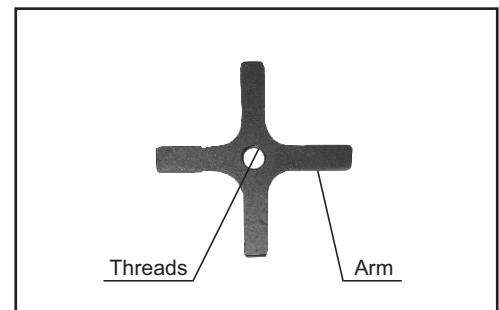

Fig.B

Check for OD of gear control rod for wear and damage to threads.

Service limit - **19.90 mm**

Check for clearance between OD of gear control rod and drive shaft.

Service limit - **0.210 mm.**

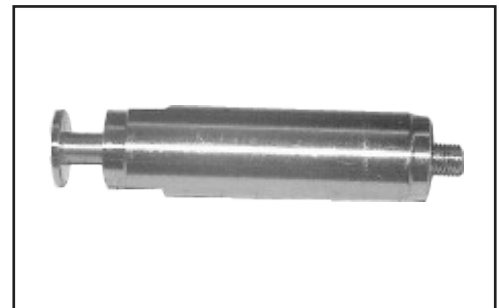

Fig.C

### ASSEMBLY

Lubricate all parts with engine oil.

Assemble rear circlip and shoulder washer.

Fit selector spider in the slot by inserting it and rotating it by 90°.



Fig.D

# TRANSMISSION

Fit gear control rod into selector spider by inserting drive shaft and rotating in anti-clockwise direction (LH threads). To hold the rod, insert plate / spanner into drive shaft slot and tighten gear control rod by spanner.

Tighten Torque - **1.5 to 1.8 kg-m**

Gear control rod is to be caulked as shown in

Cut a conic appendix 'C' of 70° as illustrated in Fig B. In a flat bar 'D' (thickness 5mm) and insert the flat bar in a slot of the drive shaft until the appendix 'C' coincides with the end 'F' of the gear control rod to be caulked.

Clamp in a vice the flat 'D' bar, (the rod above), as illustrated in fig. B, then tap with a hammer on a tube (inner dia 17.5 mm) put on the rod edge 'B' to caulk the threaded rod end 'F' on the selector Spider 'A'.

**NOTE :**

Please note the selector spider has left hand thread.

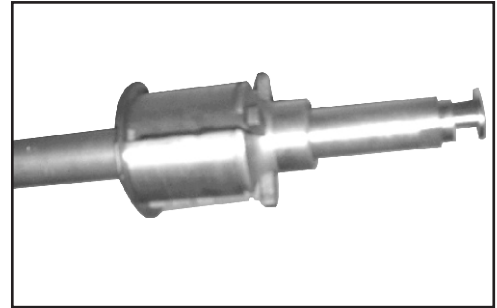

Fig. A

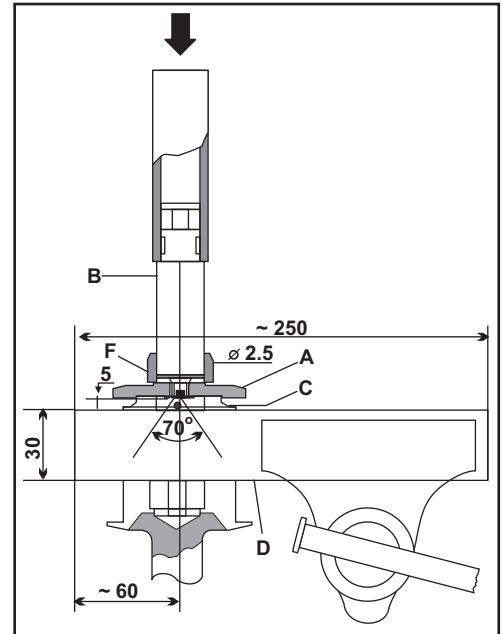

Fig. B

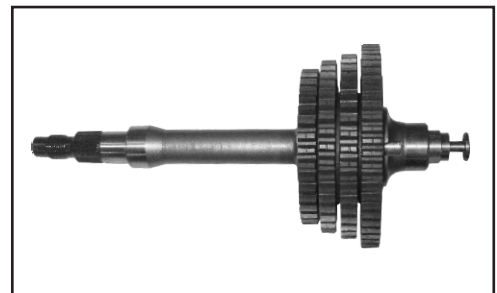

Fig. C

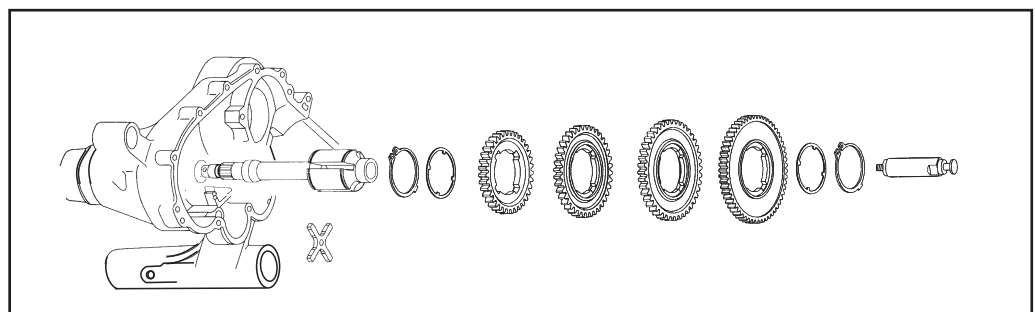

Fig. D



## TRANSMISSION

Fit all speed gears as shown in sketch in a sequence 4<sup>th</sup>, 3<sup>rd</sup>, 2<sup>nd</sup> and 1<sup>st</sup> gear sliding it over selector spider.  
Fig. A.

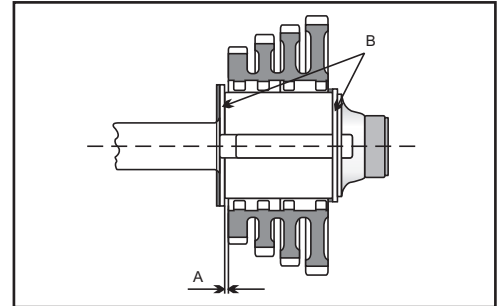

Fig. A

Fit suitable shoulder washer and outer circlip.  
Fig. A.

Check axial play with feeler gauge **G-2107025**.  
Fig. A and B.

Clearance 'A' should be between 0.15 to 0.40mm.

### SHOULDER WASHER

Category	Dim. (mm)	Limits (mm)	Clearance 'A' on assembly
Standard	1	+0 -0.06	
1st o/s	1.1	+0 -0.06	0.15 to 0.40
2nd o/s	1.2	+0 -0.06	mm
3rd o/s	1.3	+0 -0.06	
4th o/s	1.5	+0 -0.06	

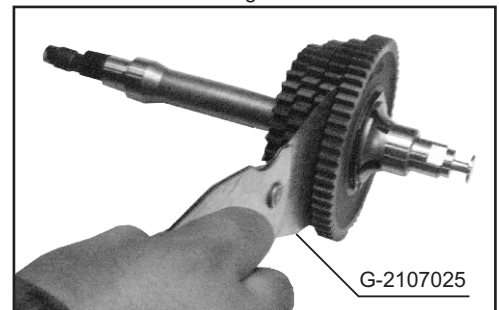

Fig. B

#### NOTE :

If the clearance "A" is not obtained by using the normal spacer washer "B", then fit over size washer to obtain prescribed clearance. Use a feeler gauge.

Fit ball bearing, circlip and dust seal from outside and oil seal from inside refer Page No. 144.

Fit drive shaft assy. in clutch side crank case with the help of Tool No. **F-2306849**.  
Fig. C.

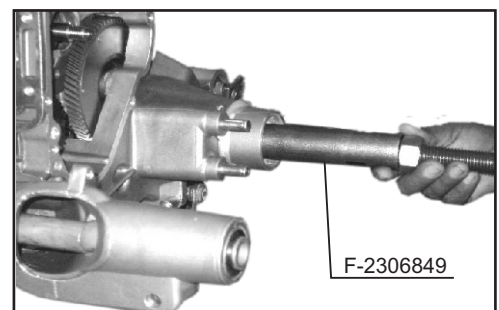

Fig. C

Ensure parts of fly wheel side crank case are assembled.

Assemble crank case halves Page 146.

## TRANSMISSION

### SPRING GEAR AND COUNTER SHAFT ASSEMBLY

#### REMOVAL

Open crank case halves Page 146.

Remove drive shaft assembly Page 131.

Remove starter gear and its spring

Remove counter shaft 1<sup>st</sup> gear by pulling.

Remove counter gear 2<sup>nd</sup> and 3<sup>rd</sup>.

Remove spring gear assembly from crankcase.

Fig. A.

#### INSPECTION

Wash all parts of counter gear assembly in solvent and blow dry with compressed air.

Check spring gear, 2<sup>nd</sup> and 3<sup>rd</sup> counter gear and counter shaft 1<sup>st</sup> gear for abnormal wear or damage to teeth.

Check counter gear shaft OD and ID of gears, if abnormal wear is noticed. Replace, if required.

Check starter gear for abnormal wear. Replace, if required.

Check spring of starter gear for fatigue / deformation. Replace, if required.

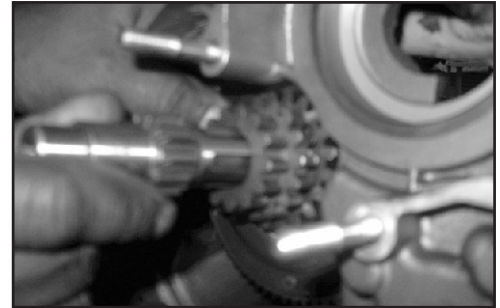

Fig. A

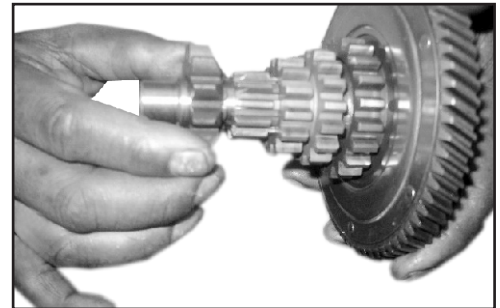

Fig. B



Fig. C



Fig. D

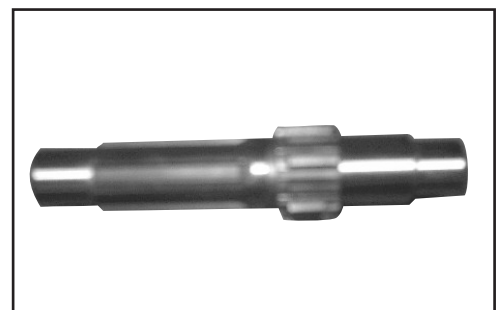

Fig. E

## INSTALLATION

Fit spring gear assembly into the crankcase for its housing.

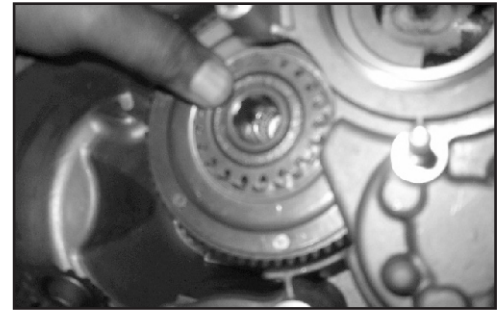

Fig. A

Keeping 2<sup>nd</sup> and 3<sup>rd</sup> counter gear inline with spring gear, insert counter shaft 1<sup>st</sup> gear through 2<sup>nd</sup> and 3<sup>rd</sup> gear and spring gear into needle roller bearing.

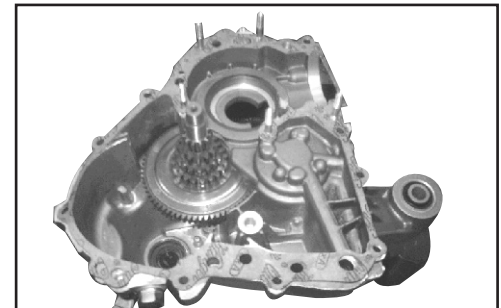

Fig. B

Fit starter gear, starter gear spring and thrust washer.

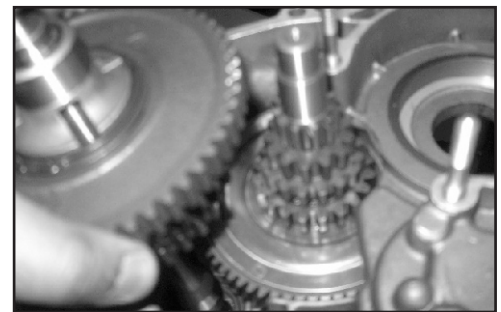

Fig. C

Fit drive shaft assy. Page 145.

Fit crank case halves. Page 146.

## TRANSMISSION

### CRANK SHAFT

#### REMOVAL

Separate crank case halves. Page 146.

Remove drive shaft assembly.

Fig. A.

Remove spring gear assembly. Page 136.

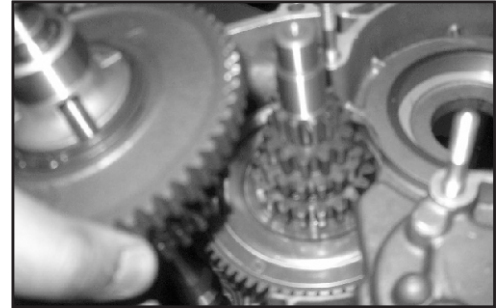

Fig.A

Fix special Tool No. **H-3391520** on crankcase and screw in the centre bolt of special tool. Expel the crank shaft assembly with bearing.

Fig. B.

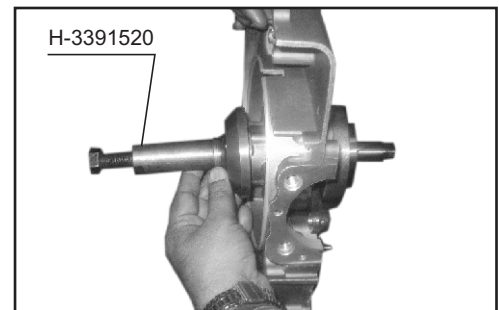

Fig.B

Use special Tool No. **H-1391608** to extract the bearing from the crank shaft assembly.

Fig. C.

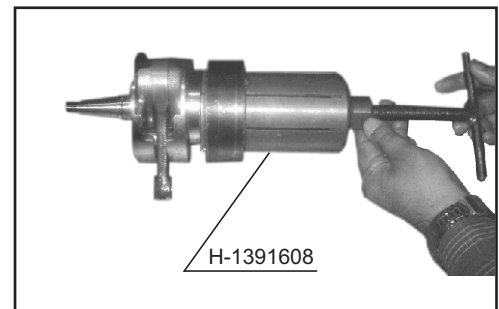

Fig.C

Remove flywheel side main ball bearing by using special Tool No. **H-3391554**.

Fig. D.

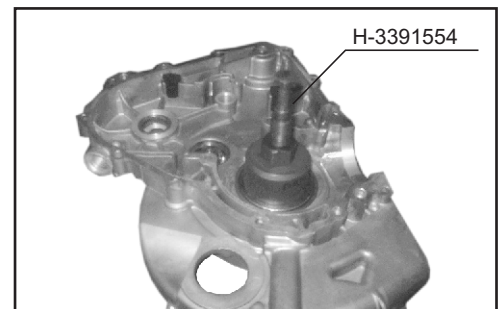

Fig.D

**INSPECTION**

Check the connecting rod big end vertical clearance by dial gauge, keeping on V-blocks.

Service limit - **0.04 mm.**

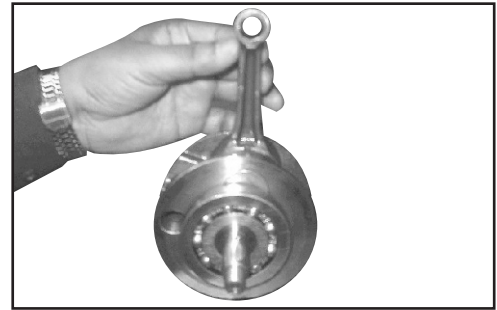

Fig. A

Measure the side clearance with the help of feeler gauge.

Service limit - **0.5 mm.**

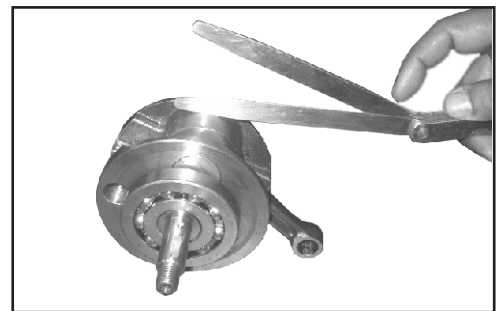

Fig. B

Use Tool No. **H-1391528** and measure run out at 'A' and 'B' of the crankshaft. Difference in reading is to be divided by 2 to arrive at run out value.

Service limit - **0.1 mm.**

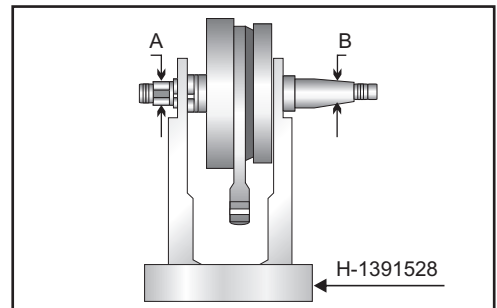

Fig. C

Rotate the bearing outer race keeping inner race tight. Rotation should be smooth and without noise.



Fig. D

# TRANSMISSION

## INSTALLATION

Clean inside of crankcase and check for cracks or any other damage.

For fitment of new studs in crank case check the table given on Page 15.

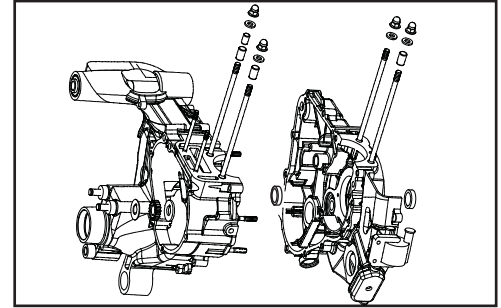

Fig. A

Fit ball bearing, needle roller bearing with proper lubrication in crank case. Page 143 & 144.

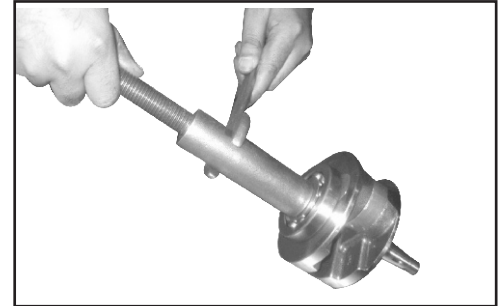

Fig. B

Fit ball bearing in crank shaft assembly using special Tool No. **F-2375558**.  
Fig. B.

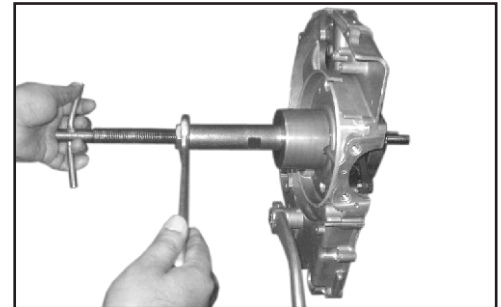

Fig. C

Pull crank shaft assembly with ball bearing into flywheel side crank case through main bearing by using special Tool No. **F-2306849**.  
Fig. C.

Install spring gear assembly and drive shaft assy.

Assemble crank case halves.  
Fig. D.

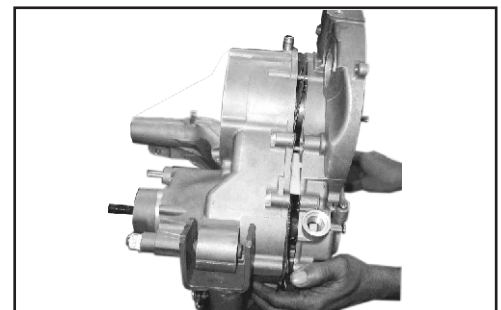

Fig. D

## CRANK CASE BEARING REPLACEMENT

### FLY WHEEL SIDE

#### REMOVAL

Extract main bearing from this crank case half. Use special Tool No. **H-3391554**. (Bearing extractor with spacer).

Fig. A.

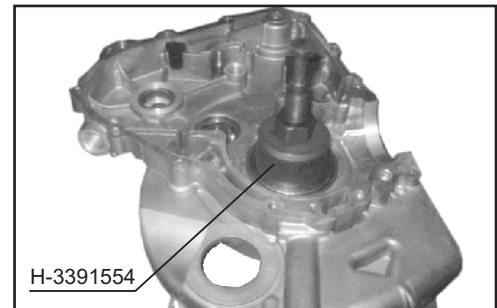

Fig. A

Extract ball bearing from counter shaft assembly, using special Tool No. (**H-3391562**)

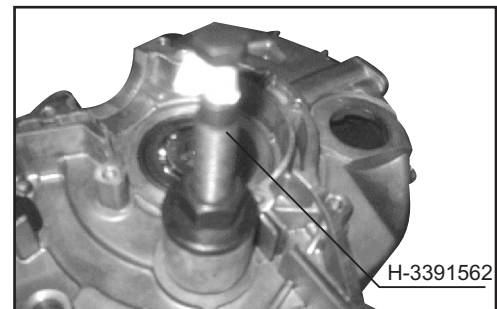

Fig. B

Extract drive shaft roller bearing with help of special Tool No. **H-3391559**. (Extractor for bearing with spacer)

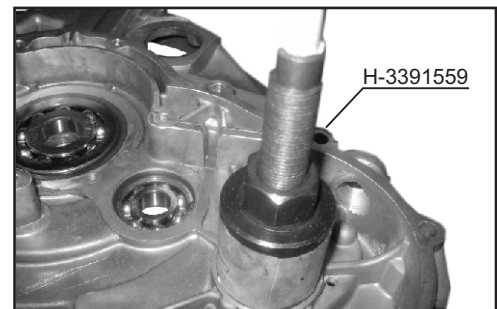

Fig. C

### CLUTCH SIDE

Remove dust seal by screw driver.

Fig. D.

Remove drive shaft Page 138.

Remove circlip from outside and oil seal from inside of crank case.

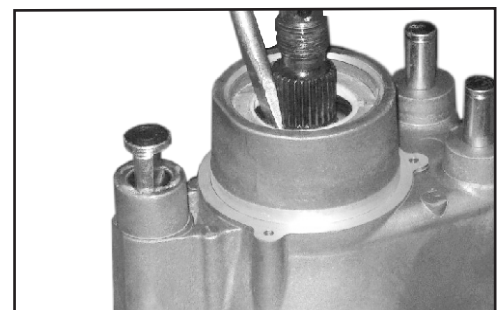

Fig. D

## TRANSMISSION

Expel ball bearing of drive shaft from crankcase by using Tool No. **H-3391558**.

Fig. A.

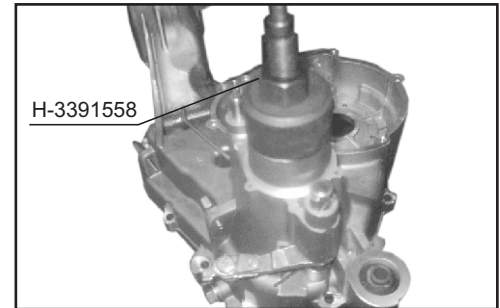

Fig. A

Needle roller bearing of the spring gear is removed with the help of Tool No. **H-3391564**.

Fig. B.

Remove buffers 2 nos. for starter sector.

Page 129.

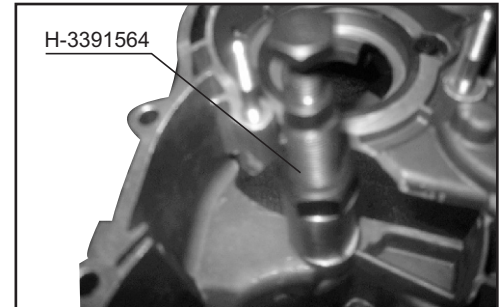

Fig. B

## INSPECTION

Clean all bearings with solvent thoroughly and blow-dry with compressed air. Apply clean engine oil.

Fig. C.



Fig. C

Check for free rotation and abnormal noise. Replace, if required.

Check buffers for damage / deterioration. Replace, if required.

Fig. D.

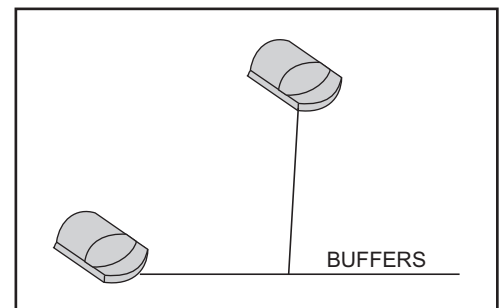

Fig. D



## INSTALLATION OF BEARINGS

### FLY WHEEL SIDE CRANK CASE

Apply clean lubricant to the bearings.

To fit ball bearing in crank case for crank shaft use Tool No. **H-3391531**

Fig. A.

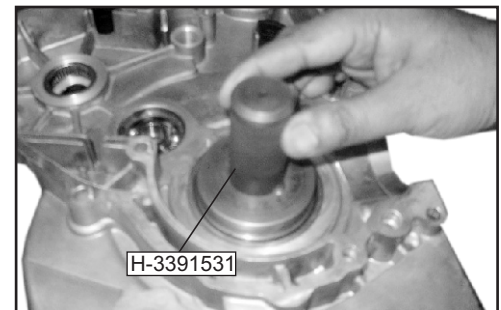

Fig. A

To fit counter shaft ball bearing use special Tool No. **H-3391563**.

Fig. B.

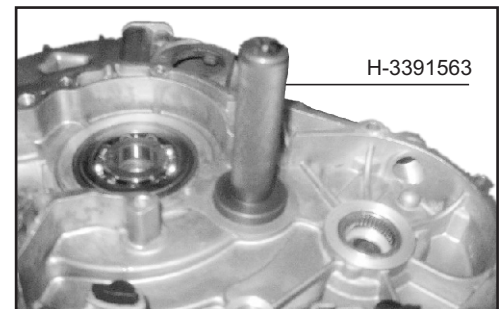

Fig. B

Fit circlip above the bearing in the groove with the help of pliers.

To fit needle roller bearing use special Tool No. **H-3391529**.

Fig. C.

Fit buffers 2 nos. for starter sector.

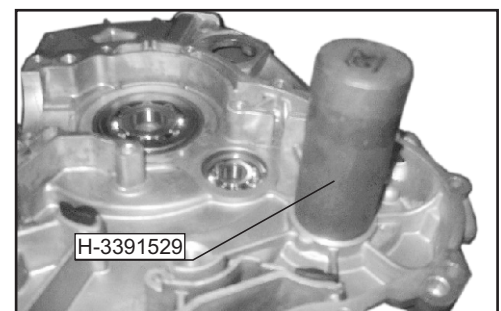

Fig. C

# TRANSMISSION

---

## CLUTCH SIDE CRANK CASE

Apply lubricants to the bearings.

Fit ball bearing for drive shaft using special Tool No. **H-3391560**.

Fig. A.

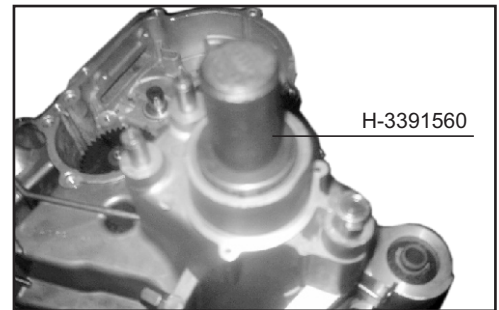

Fig. A

Fit circlip and dust seal.

Fit oil seal by special Tool No. **H-3391561** from inside of crank case.

Fig. B.

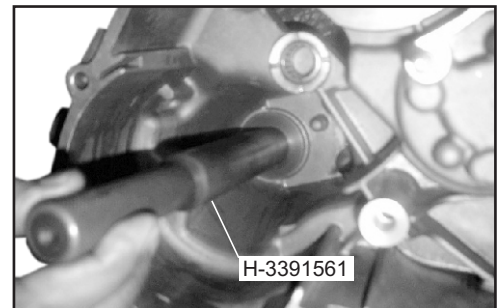

Fig. B

Fit needle roller bearing for counter shaft using special Tool No. **H-3391565**.

Fig. C.

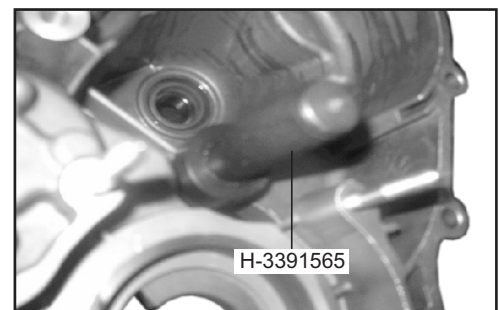

Fig. C

## CRANK CASE ASSEMBLY

Flywheel side crank case is fitted with 2 ball bearings and 1 needle roller bearing.

Fig. A.

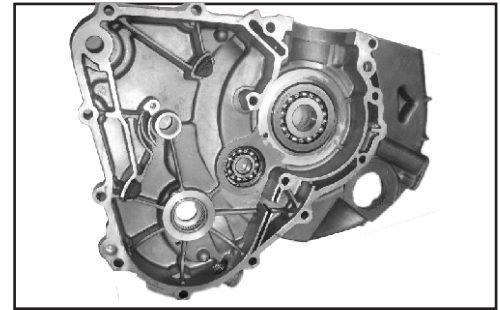

Fig. A

Fly wheel side assembly is fitted with starter sector and kick assembly. Page 127 and 130.

Crank shaft assembly is fitted in fly wheel side crank case. Page 140.

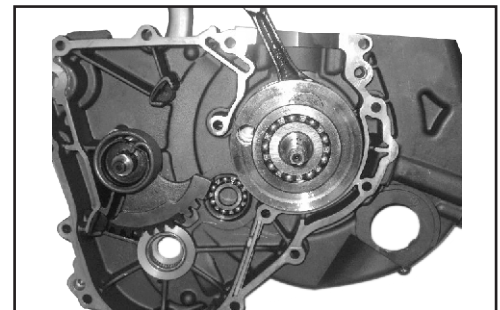

Fig. B

In clutch side crank case fit bearing, circlip dust seal from outside and oil seal from inside. Page 144.

Fit spring gear assembly and counter shaft.

Fig. C.

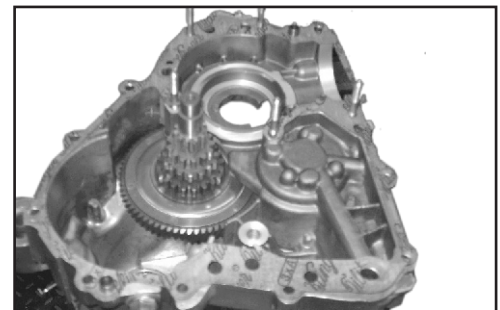

Fig. C

Fit drive shaft assembly.

Fig. D.

Fit starter gear, spring for starter gear and thrust washer.

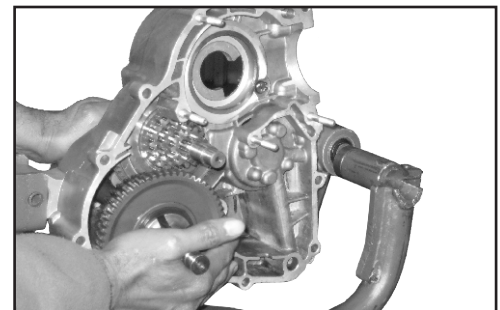

Fig. D

Fit 2 nos. of dowels and new gasket.

## TRANSMISSION

Install flywheel side crank case on clutch side crank case carefully so that thrust washer above the spring for starter gear does not fall.

Fig. A.

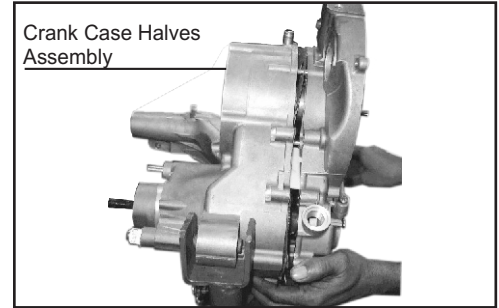

Fig. A

Fit crank case bolts / nuts / curved washers. Tighten them in criss cross manner and in 2 / 3 steps for equal tightening pressure.

Fit flywheel side oil seal using special Tool No.

**H-3391532.**

Fig. B.

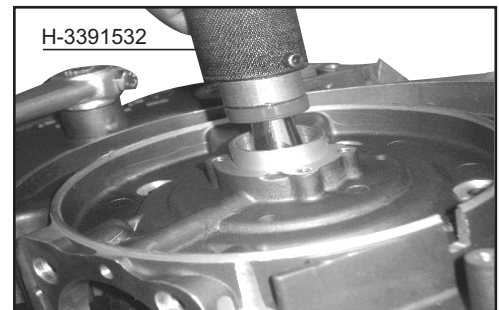

Fig. B

Fit flywheel magneto, gear control bracket and kick assy.

Fig. C.

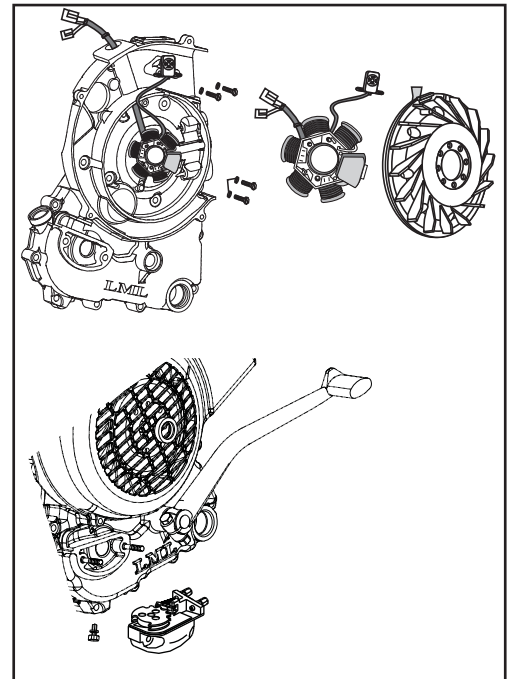

Fig. C

Fit pinion gear, idler gear set, piston, cylinder block, cylinder head, silent chain with sprockets. See respective chapters.

Fig. A.

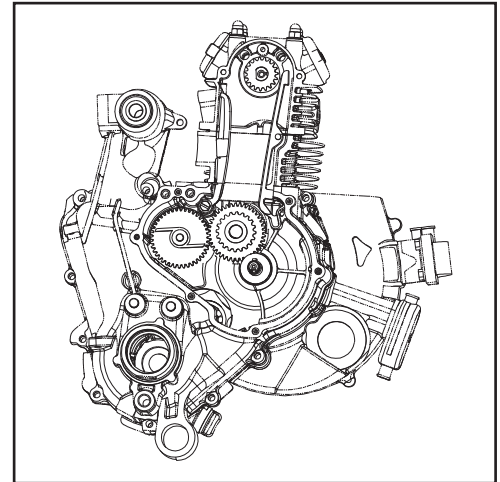

Fig. A

Fit carburettor and manifold assy.

Fit fan cover and cooling hoods. See respective chapters for procedure.

Fig. B.

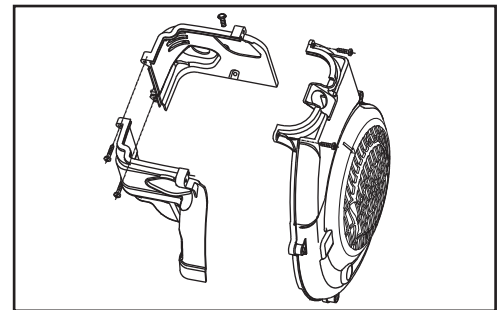

Fig. B

Fit engine on link assembly of chassis.

Fit all control cables and take a trial run.



Fig. C

---

# CHASSIS

## INDEX

### PAGE No.

GENERAL SERVICE DETAILS	149
LINK ASSEMBLY TO CHASSIS	151
FRAME SHELL REMOVAL AND INSTALLATION	153

## GENERAL SERVICE DETAILS

Link stopper rubber pad, should be replaced even if damage is small, to avoid vibration.

Link bolt should not be loose in chassis's holes.

Rubber pads and cowl buffers should be replaced, if damaged.

Paint protection stickers are to be peeled off and replaced, if damaged.

Proper connection of cable harness for tail light should be ensured.

## TORQUE VALUES

Special bolt for link assembly to chassis	-	<b>5 to 6 Kg-m.</b>
Screws 6 Nos. tightening shell to foot board	-	<b>0.9 Kg-m.</b>
Flange bolts 2 Nos. shell to frame	-	<b>2.7 Kg-m.</b>
Screw 2 Nos. to securing plate	-	<b>1.2 Kg-m.</b>
Top mounting bolt for rear shock absorber	-	<b>2.5 to 2.7 Kg-m.</b>

# CHASSIS

## FRAME

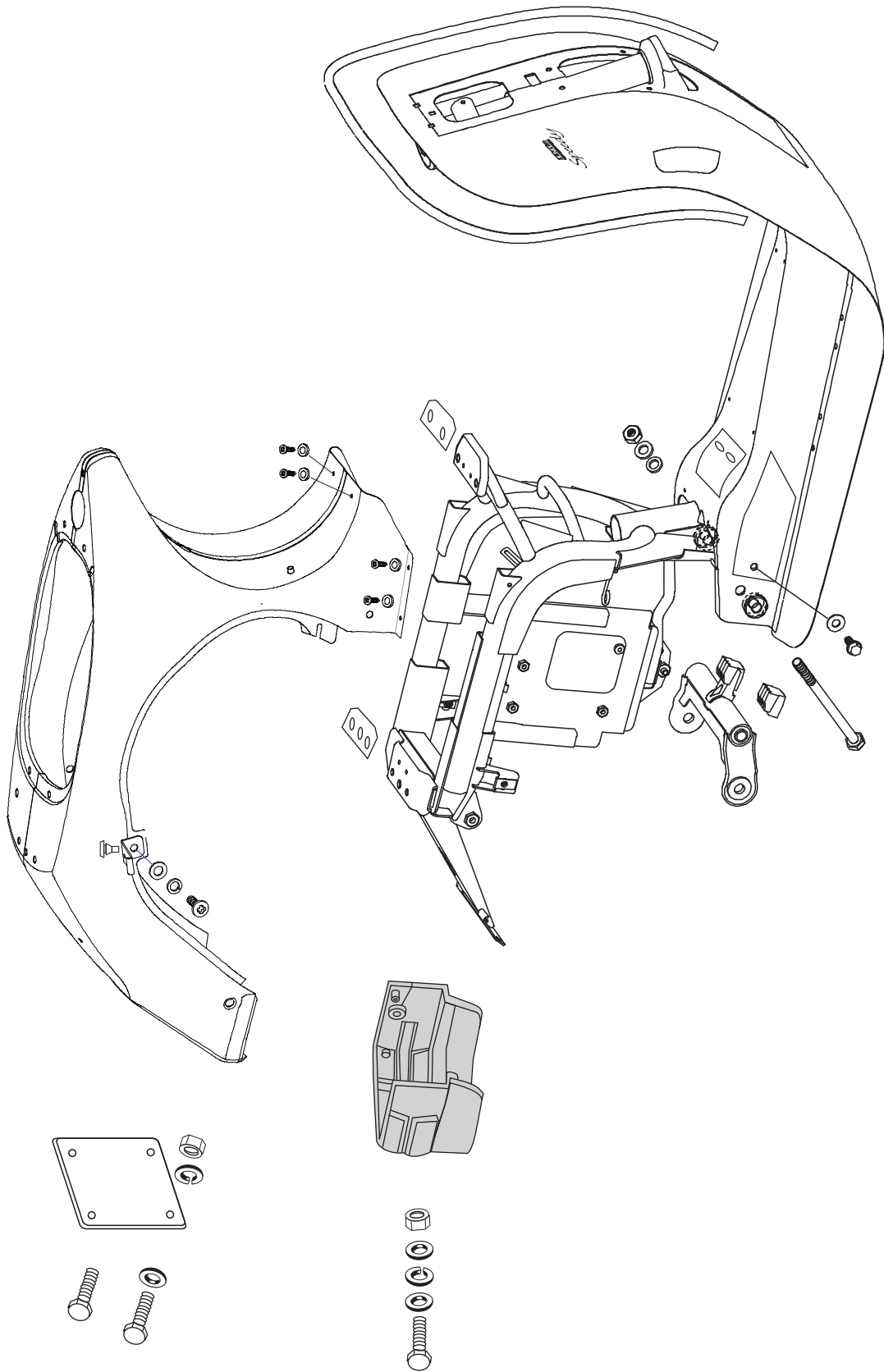

**LINK ASSEMBLY TO CHASSIS****REMOVAL**

Open the nut, spring washer and plain washer and remove special bolt (12 mm) from chassis and link assembly.

Fig. A.

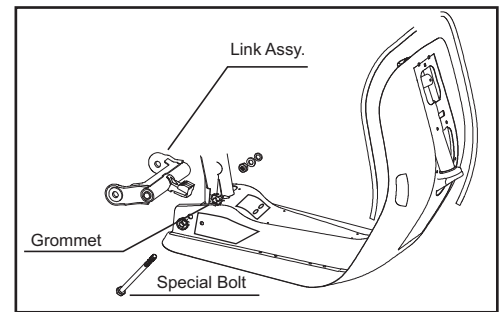

Fig. A

Take out the link with rubber damper from its housing in the chassis.

Fig. B.

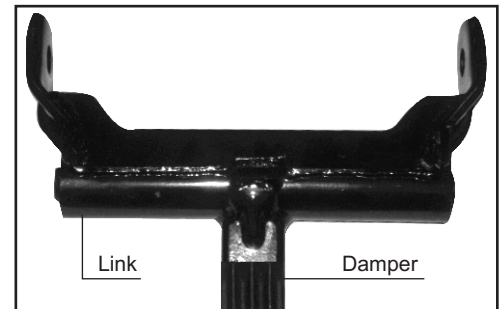

Fig. B

Take out damper from its bracket on link assembly.

Fig. C.



Fig. C

**INSPECTION**

Check for deterioration of rubber damper and replace, if required.

Check threads of special bolt and nut, and replace, if required.

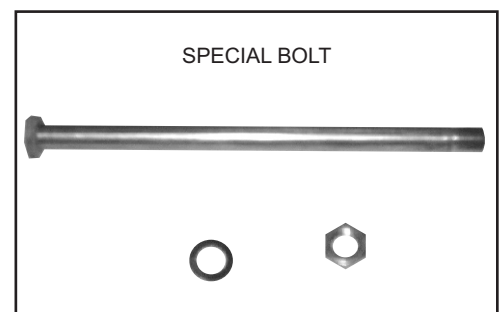

Fig. D



## CHASSIS

---

### ASSEMBLY

Insert damper on front bracket of link assy.

Fig. A.

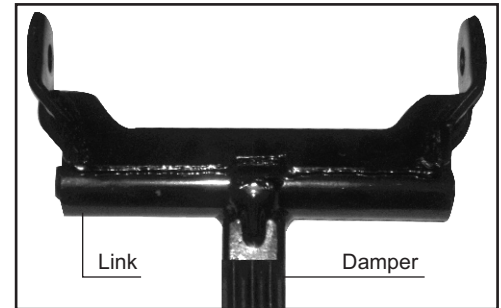

Fig. A

Insert damper into chassis housing and fix tube portion of link into the chassis location, for it.

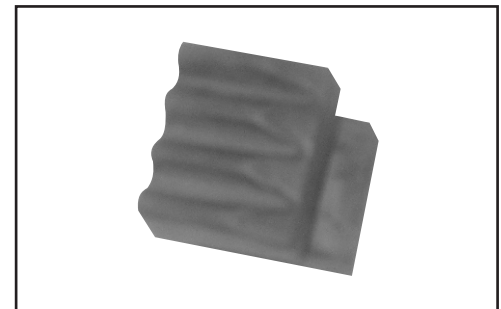

Fig. B

Insert special bolt (12 mm) through chassis holes passing through mounting link and tighten it with plain washer and nut.

Fig. C & D.



Fig. C

Tightening Torque - **5 to 6 kg-m.**

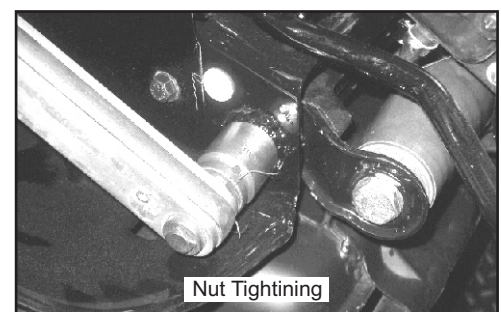

Fig. D

---

## FRAME

### BODY SHELL AND FRAME

Frame of LML 4S is of semi monococque pressed sheet steel and at rear, a strong tubular structure. A pressed steel sheet shell, covers the tubular structure. Shell assembly is seldom required to be opened / replaced.

For disassembly of shell assembly, it is necessary to open LH & RH cowl assemblies, dual seat assembly, back rest, fuel tank assembly, number plate, rear protection, rear shock absorber and spare wheel.

Disconnect tail lamp cable harness and other electrical parts.

### REMOVAL

Remove the seat by opening three bolts.

Fig. A.

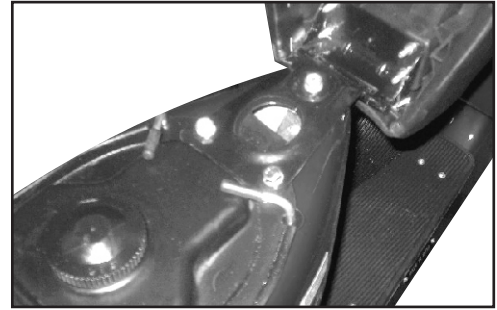

Fig. A

Open the two bolts to remove the fuel tank assy. Remove the fuel cock rod and fuel pipe. Take fuel tank assembly and its gasket.

Remove back rest & lock pin/bracket.

Remove number plate and rear protection.

Fig. B.

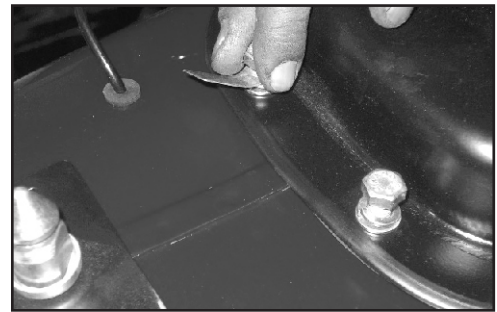

Fig. B

Remove six self tapping screws and plain washers, from foot board area.

Fig. C.

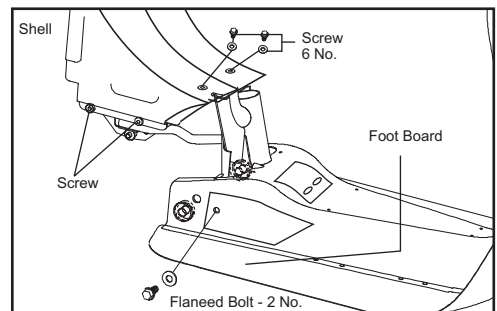

Fig. C

## FRAME

Remove the two nos. flanged bolts with plain washer from foot board area.

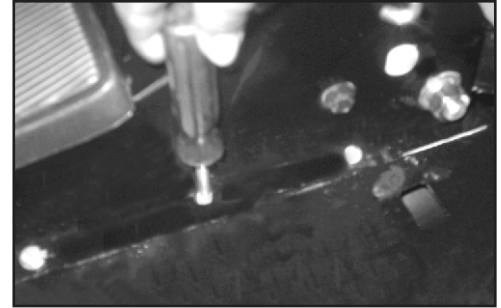

Fig. A

Remove two screws and take out spring washer and plain washer of the securing plate from cowl fixing area.  
Fig. B.

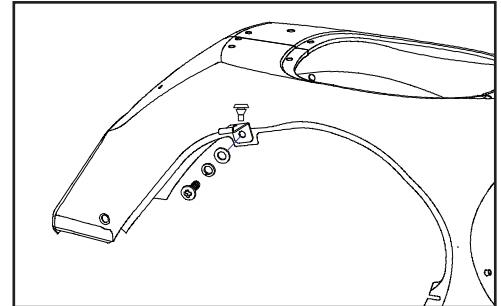

Fig. B

Remove four number plate bolts to remove the number plate.  
Fig. C.

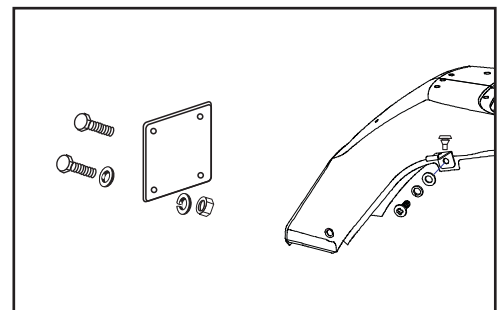

Fig. C

Disconnect tail lamp harness and other electrical parts.  
Remove the two bolts of the rear protection from frame and take out rear protection.  
Fig. D.

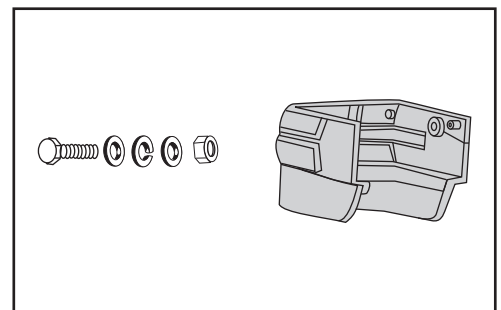

Fig.D

Remove the shell from the frame, by lifting upwards.  
Fig. E.

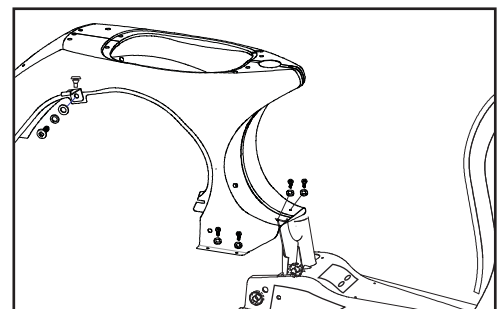

Fig. E

**INSPECTION**

Inspect the mating surface for wear.

Inspect the front and rear rubber pad. If damaged, replace with new.  
Fig. A & B.

Check the cowl buffers, if damaged, replace with new.

Check condition of 3 stickers, provided in foot board area for paint protection. Replace, if required.  
Fig. C.

**INSTALLATION**

Put the front and rear rubber pads.

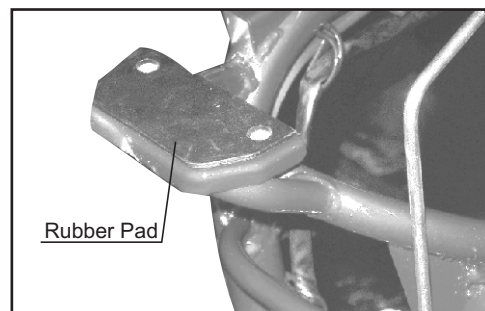

Fig. A

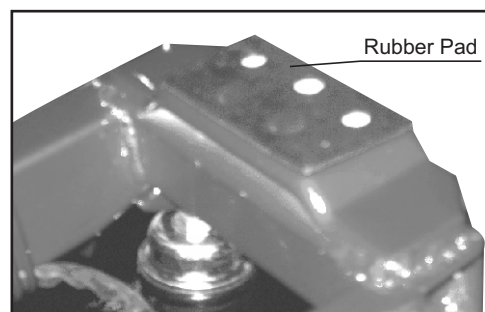

Fig. B

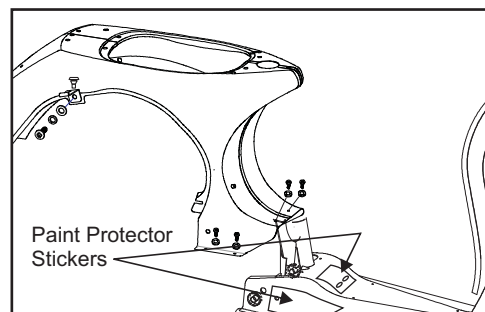

Fig. C

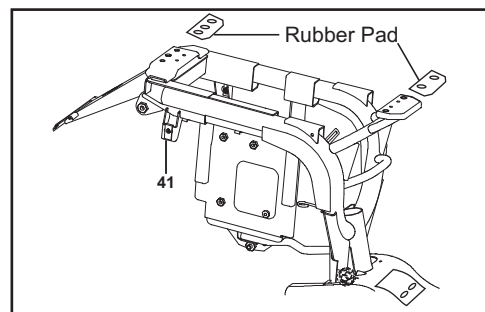

Fig. D

## FRAME

---

Fit special bolt for rear shock absorber.

Tightening Torque - **2.5 to 2.7 Kg-m.**

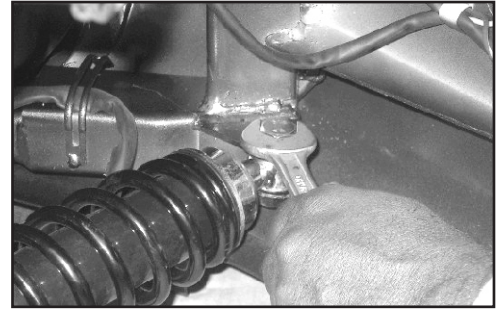

Fig. A

Place the shell on the frame.

Tighten the LH & RH flanged bolts.

Tightening Torque - **2.7 Kg-m.**

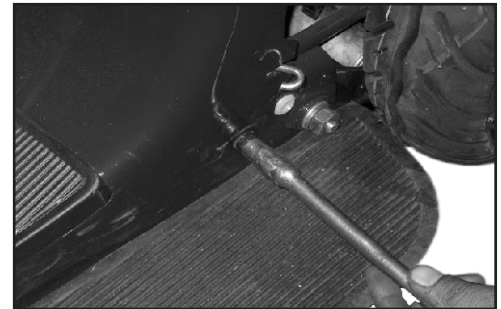

Fig. B

Tighten the screw of the securing plate of LH & RH side.

Tightening Torque - **0.9 Kg-m.**

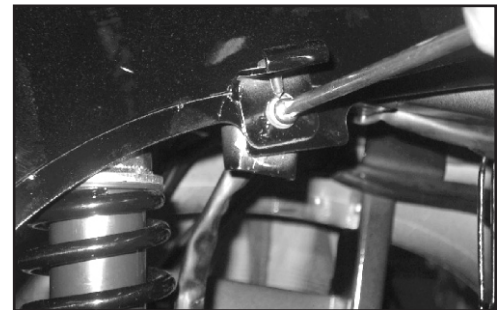

Fig. C

Assemble number plate by four bolts, nuts, spring and plain washer.

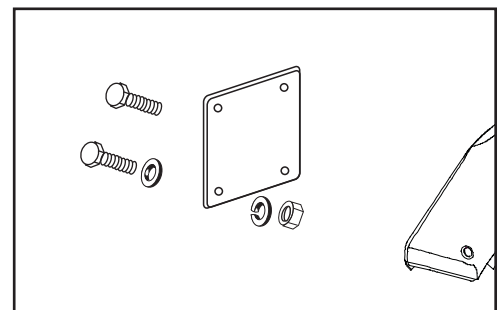

Fig. D

Assemble rear protection of frame by two bolts, nuts, spring washer and plain washer

Connect tail light harness and other electrical parts.

Assemble fuel tank by two bolts spring washer and plain washers. Fit fuel cock rod.

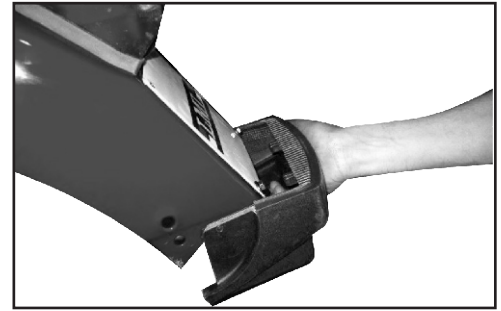

Fig. A

Assemble seat assembly by 3 bolts, spring washer and plain washers.

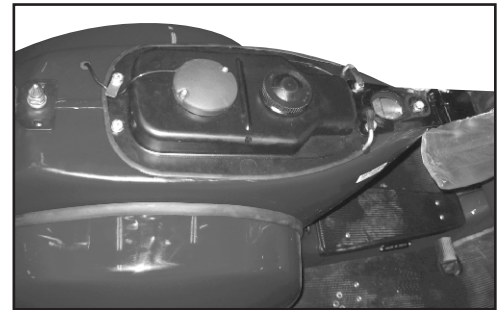

Fig. B

Fix the shell to frame by tightening the six self tapping screws and plain washer.

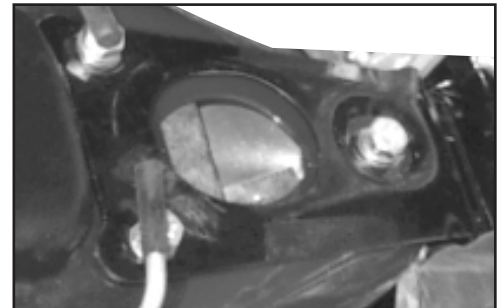

Fig. C

---

## FRONT BRAKE DRUM / SUSPENSION / STEERING

### INDEX

	PAGE No.
SERVICE DETAILS	159
FRONT BRAKE DRUM	160
SUSPENSION	168
STEERING COLUMN	171

### GENERAL SERVICE DETAILS

Brake shoe dust is hazardous to health.

Avoid inhalation of dust particles.

After removing contamination never use compressed air for cleaning the brake shoe dust.

Contaminated brake shoe increases the stopping distance. Do not use contaminated brake shoes, discard them. Contact area in brake drum for brake shoe packing should be cleaned with high quality cleaning agent.

Before riding scooter, always check braking operation.

Always use genuine LML parts only.

### SPECIFICATIONS

Minimum tyre thread depth	0.8 mm		
Front axle run out	- 0.20 mm		
Front rim assy. run out (axial)	- 1.6 mm		
Front rim assy. run out (radial)	- 1.6 mm		
Front brake lever free play	- 5.0 mm		
	- Single riding		Riding with Pillion
Tyre Pressure front	- 1.2 kg/cm <sup>2</sup>	-	1.2 kg/cm <sup>2</sup>
Tyre Pressure rear	- 1.8 kg/cm <sup>2</sup>	-	2.5 kg/cm <sup>2</sup>
	-	-	

### TORQUE VALUES

Front axle nut	7.5 to 9.0 kg-m.
Front wheel nuts	- 2 to 2.7 kg-m.
Handlebar tightening bolt	- 3 to 4.4 kg-m.
Steering column upper bearing nut	- 5 to 6 kg-m.
Steering column upper ring nut	- 3 to 4 kg-m.
	-

## FRONT BRAKE DRUM

### FRONT BRAKE DRUM ASSEMBLY

#### REMOVAL

Remove wheel cover.

Remove front wheel rim assembly with tyre tube by opening 5 nuts and spring washer.

Fig. A.

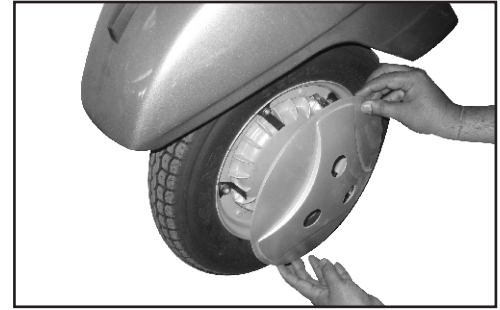

Fig. A

Remove the dust cap **A**, split pin **B** and lock cap **C**.

Fig. B.

Open the nut and take out the front brake drum.

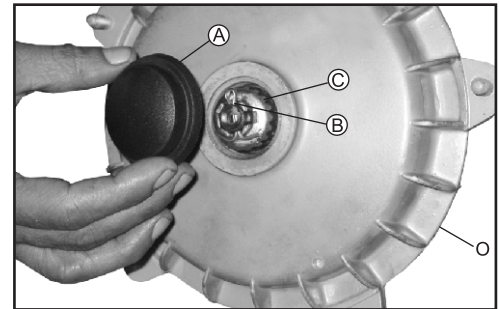

Fig. B

Take out the circlip **G** and ball bearing **H**.

Fig. C and D.

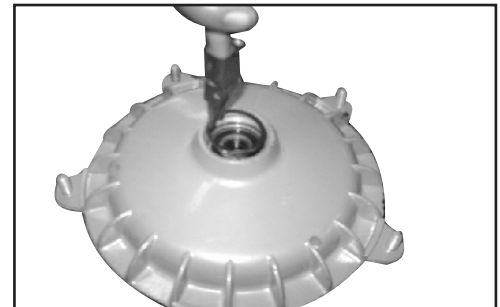

Fig. C

Take out the oil seal and DC roller bearing from other side with the help of suitable punch.

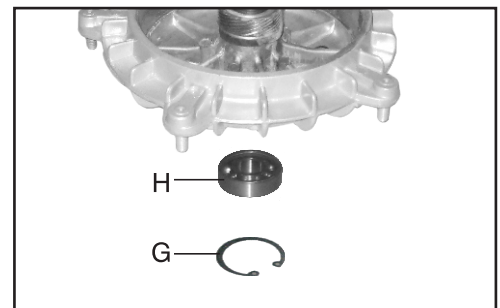

Fig. D



## FRONT BRAKE DRUM

Take out speedo gear from brake drum, if necessary.  
Fig. A.



Fig. A

### INSPECTION

Wash all the parts and blow-dry by compressed air.

Turn the outer race of the ball bearing, holding inner race and see if it runs freely and quietly. Replace, if required.



Fig. B

Also check that the bearing is not loose in the brake drum. Replace brake drum, if required.

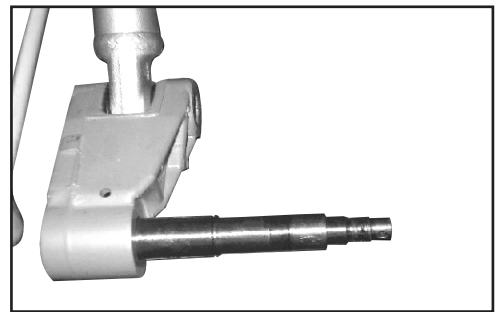

Fig. C

Check needle roller bearing for play on axle shaft and replace, if required.



Fig. D

Check speedo gear for damage. Replace, if required.

Check brake drum at liners contact surface, if surface is found very smooth then rub the face with emery paper of 80/100 grade. If deep cuts are observed on the face, replace front brake drum.



Fig. E

Check brake drum ID at shoe contact dia.

Service limit - **151.0 mm**

## FRONT BRAKE DRUM

### ASSEMBLY

Heat bearing zone with heater.

With the help of Tool No. **H-3391541** fit roller bearings in brake drum. Fix new oil seal.

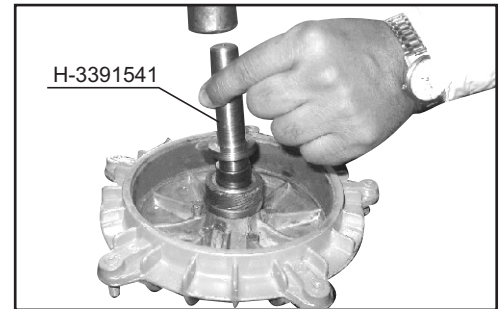

Fig. A

Fit ball bearing with punch dia of 34 mm.

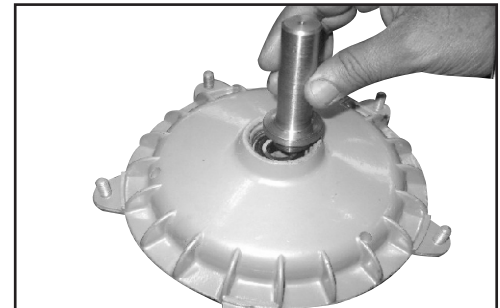

Fig. B

Lock bearing with circlip.

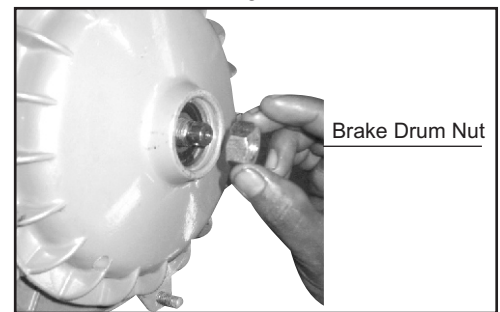

Fig. C

Refit brake drum assembly by lock washer, nut, split pin.

Tightening Torque - **7.5 to 9.0 kg-m.**

Fit cap.

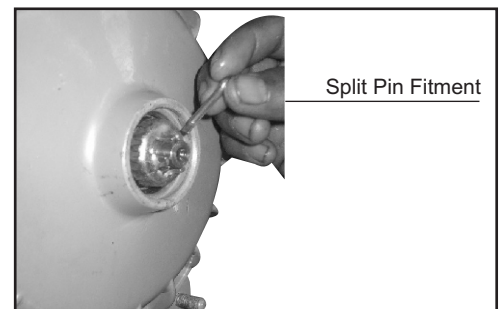

Fig. D

Fit wheel and rim assembly with 5 spring washers and nuts.

Tightening Torque - **2.0 to 2.7 kg-m.**



Fig. E

## FRONT BRAKE DRUM

### BRAKE JAW HOLDING PLATE

#### REMOVAL

Remove front brake drum. Page 150

Remove shock absorber by opening two bolts.

Fig. A.

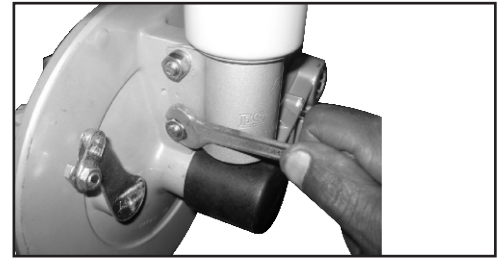

Fig. A

Remove speedo cable by opening bolts and washer on cable securing plate.

Fig. B.

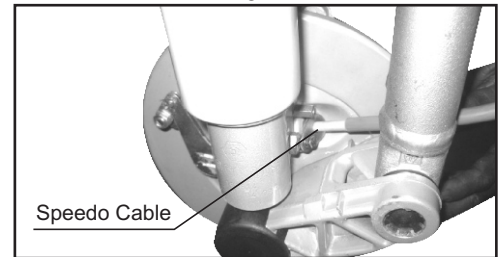

Fig. B

Take out plate, grommet, drive pinion and its housing.

Fig. C.



Fig. C

Remove brake cable by opening brake cable bolt & nut from brake link assembly.

Fig. D.



Fig. D

Remove circlip lock, spacer washer and oil seal from axle shaft.

Fig. E.



Fig. E

Take out brake jaw holding plate assembly.

Take out 'O' ring, shim washer, oil seal from axle shaft

Fig. F.

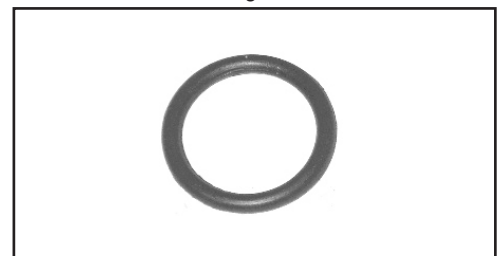

Fig. F

## FRONT BRAKE DRUM

Take out both DC roller bearings with a tube of 27 mm dia.

Fig. A.

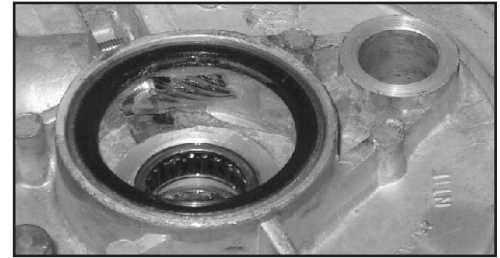

Fig. A

Take out the brake jaw set by taking out circlips and shoe securing spring.

Fig. B.

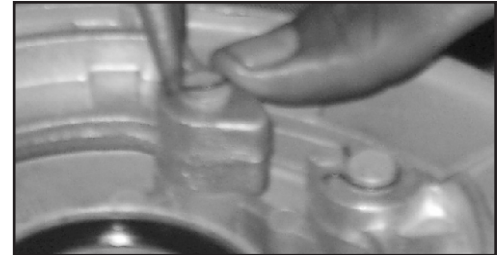

Fig. B

### NOTE :

Be careful while removing brake jaw set. It may jump due to spring action and hurt.



Fig. C

### INSPECTION

Wash all the parts and blow-dry with compressed air.

Inspect the needle roller bearings for its play by putting them on axle pin.

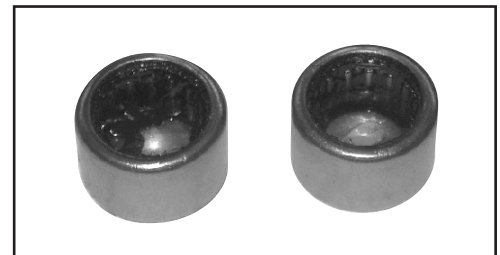

Fig. D

Inspect brake jaw assembly.

Check the brake shoe/liners for thickness wear hardness or oily surface.

Service Limit - 2.0 mm thickness of liner

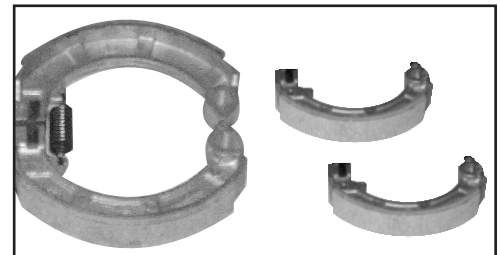

Fig. E

Check speedometer cable for any damage. Replace, if required.

Check grommet and drive pinion for damage. Replace, if required.

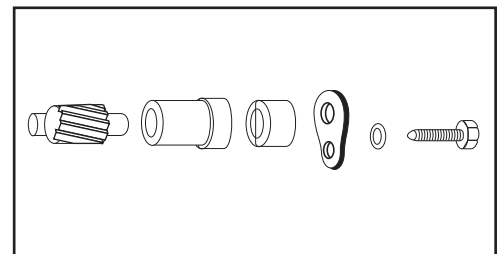

Fig. F

## FRONT BRAKE DRUM

If shoes / liners are worn out replace them.  
Fig. A

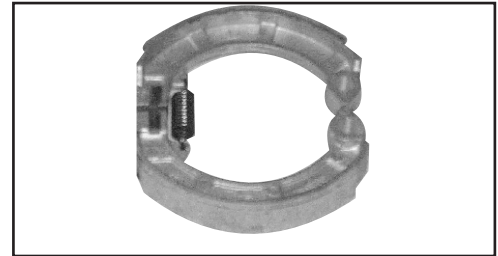

Fig. A

### ASSEMBLY

Heat the bearing zone of holding plate.

Punch fit the needle bearings with Tool No. **H-3391539** from outside and by **H-3391540** from inside respectively.  
Fig. B & C

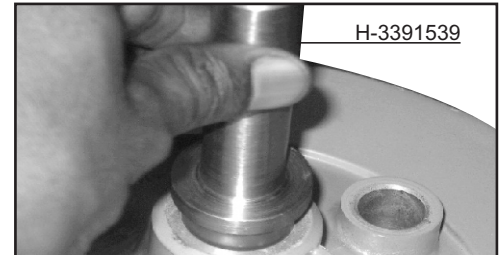

Fig. B



Fig. C

Fit small oil seal from outside and big oil seal from inside. Apply grease to holding plate bearings.  
Fig. D



Fig. D

Fit brake control lever on brake jaw holding plate.

Lubricate pins for brake jaws.  
Fit brake jaw assembly with the help of shoe securing spring.  
Fig. E

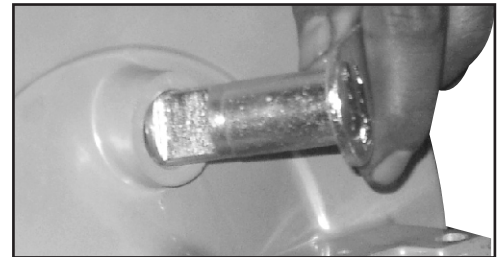

Fig. E

Fit brake jaw assembly by expanding brake shoes one by one on cam portion of brake control lever and brake shoe pin.

Lock with circlip.  
Fig. F



Fig. F

## FRONT BRAKE DRUM

Fit brake links on brake control lever by pin and split pin.

Slide 'O' ring on suspension link.

Place shim washer on axle shaft.

Fit the brake jaw plate assembly. Place shoulder washer on the axle shaft and lock by circlip 'B'.

Fig. A & B

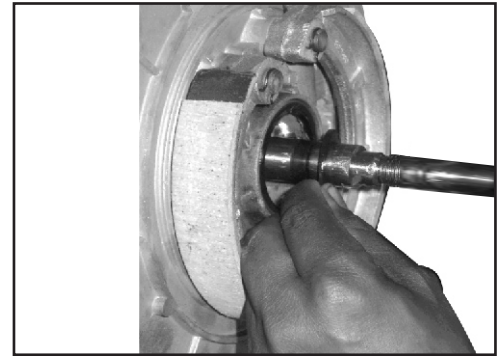

Fig. A

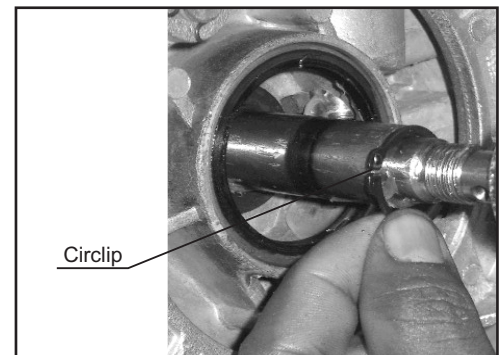

Fig. B

Fit speedo pinion and in its housing. Place new grommet and fit speedo cable with cable securing plate and tighten cable securing plate with the help of bolt and washer on brake jaw holding plate. Check working of speedometer.

Fig. C

Slip the seal 'O' ring into the gap of brake jaw holding plate and link assembly.

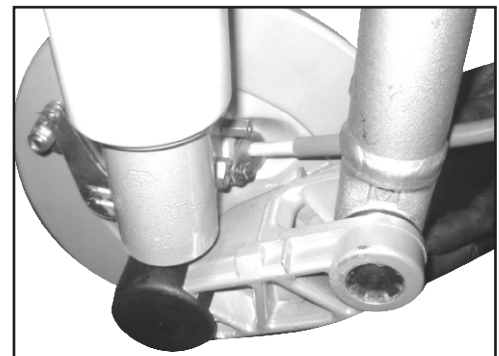

Fig. C

Fit front brake cable passing through adjusting screw with the help of nut bolt on brake links.

Fig. D

Fit the front brake drum and tighten the nut see page 162.

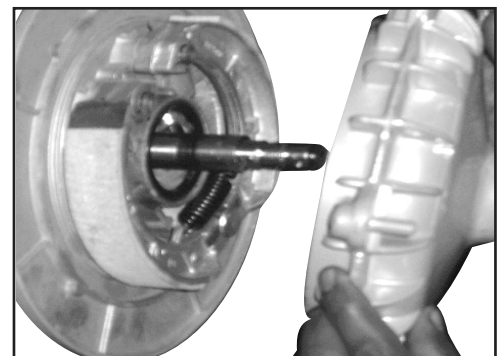

Fig. D

## FRONT BRAKE DRUM

Place lock cap and lock it with split pin and cap.

Adjust front brake cable and check for free rotation, of wheel, free play of brake lever and braking performance.

Fix dust cap.

Fit Front wheel with help of 5 nuts and bolts Page 162.

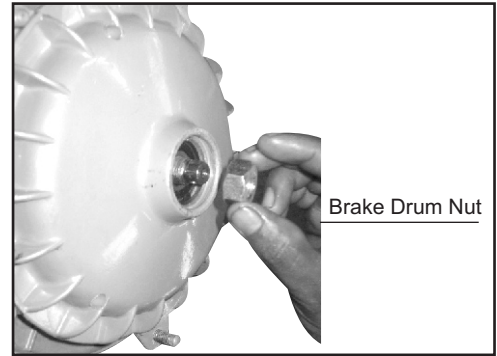

Fig. E

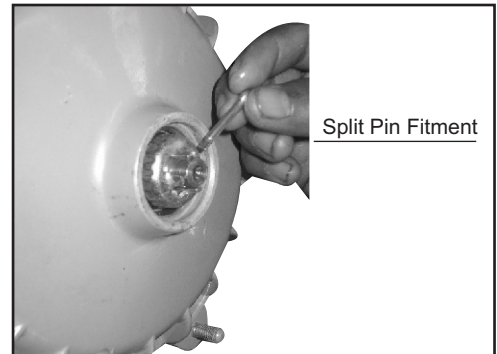

Fig. F

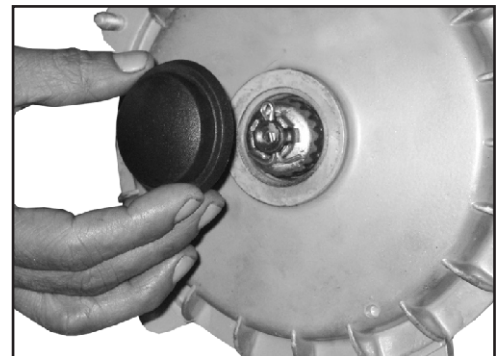

Fig. G



Fig. H

## FRONT SUSPENSION

### FRONT SUSPENSION PIN

#### REMOVAL

Use punch dia. of 12 mm. to crush the tab washer.

Remove tab washer from both sides.

Attach fixture **H-0391542** alongwith part 1 at the top and part 18 at the bottom to steering column and link assembly.

Tighten handle screw to press out suspension pin from the link and steering column.

Separate the suspension link from steering column.

Replace part 1 with part 2.

Press out 2<sup>nd</sup> DC roller bearing from link.

#### NOTE :

2<sup>nd</sup> DC roller bearing should be at the bottom side to avoid breakage of suspension link.

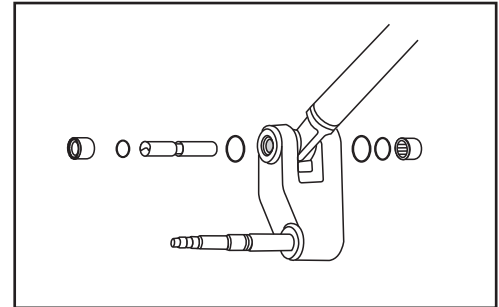

Fig. A

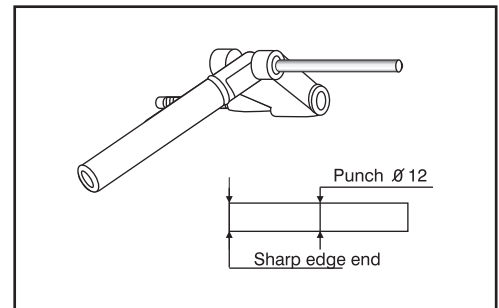

Fig. B

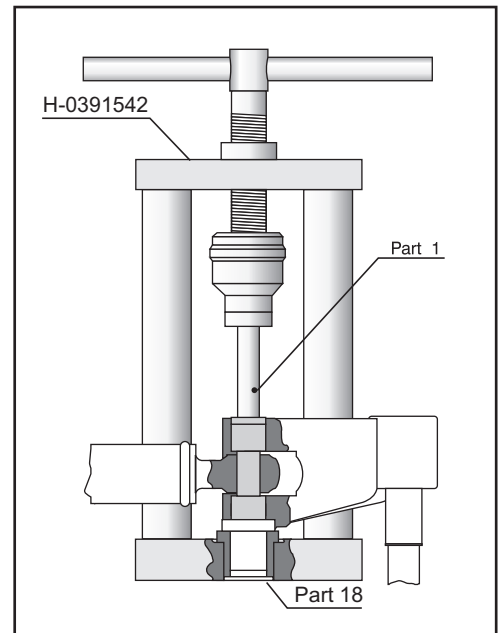

Fig. C



## FRONT SUSPENSION

### INSPECTION

Check oil seal, if damaged replace it with proper greasing.

Rotate and check DC roller bearing, if not working properly replace it.

Proper greasing to be done to all the suspension link parts.

### INSTALLATION

Place Tool No. **H-0391542** with part 3 and new suspension pin at the top and part 4 at the bottom.

Rotate screw handle until it butts the face of part 3 with swing hub.

Fig. C.

Place two spacers part 17 between hub and steering column end.

Replace part 3 at the top by part 16 and retain part 4 at the bottom.

Place oil seal, DC roller bearing on suspension pin duly lubricated alongwith tab washers.

Fig. D.

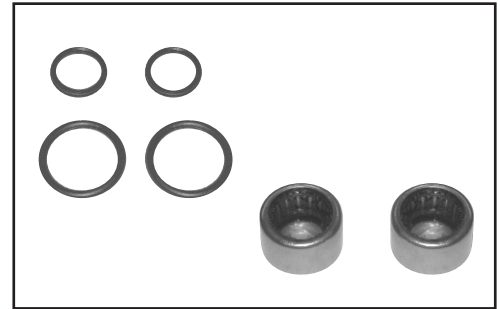

Fig. A

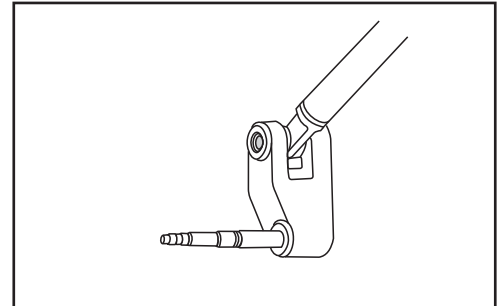

Fig. B

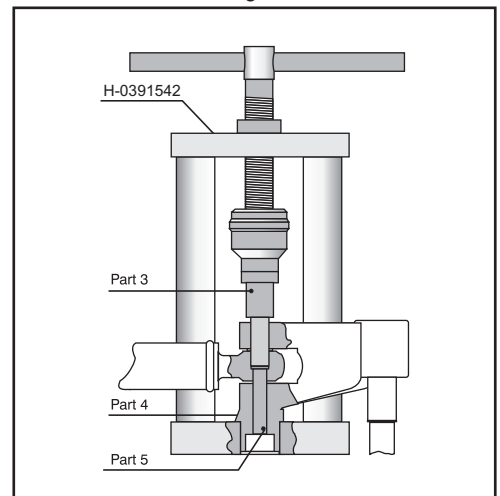

Fig. C

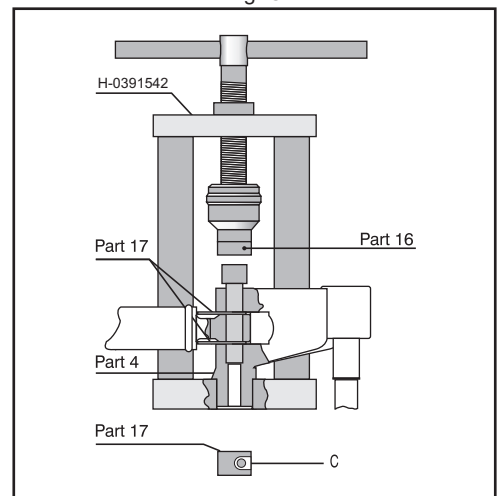

Fig. D

## FRONT SUSPENSION

Rotate screw handle until part 16 butts the face of swing hub.

Reverse the position for 2nd bearing fitment.

Fig. A.

Replace bottom part 4 with part 22 retaining part 17 in position.

Place the oil seal and DC roller bearing on suspension pin duly lubricated and press DC roller bearing along with tab washer in position.

Replace part 16 with part 20 at the top and part 22 with part 21 at the bottom.

Rotate handle and position of DC roller bearing.

Lock tab washers by using part 2 and part 4 finally and remove spacers using part 17.

Fig. B.

Place packings ('O' rings) between link and steering column gap.

Fig. C.

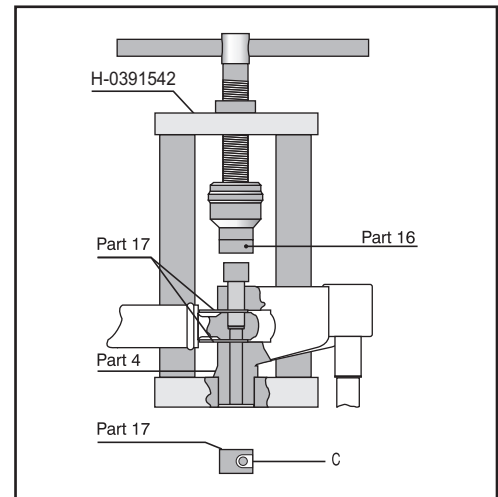

Fig. A

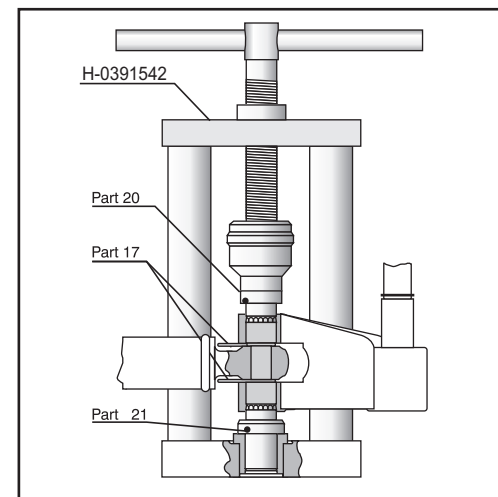

Fig. B

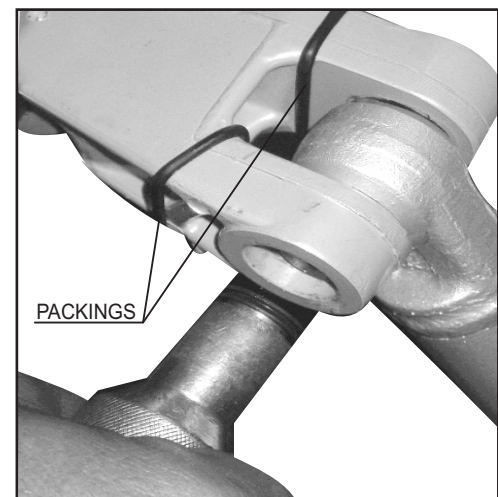

Fig. C

STEERING COLUMN

REMOVAL

Remove handle bar top by opening 4 screws, washer and disconnecting speedo cable by opening knurled nut.  
Fig. A.



Fig. A

Push down speedo cable.  
Fig. B.

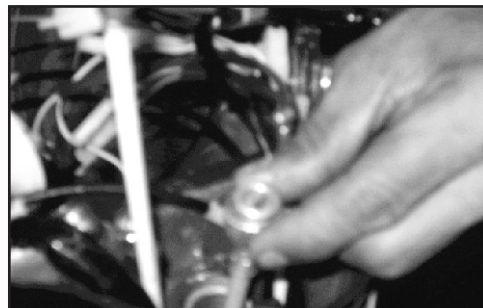

Fig. B

Disconnect all the electrical connections from the handle bar.  
Fig. C.

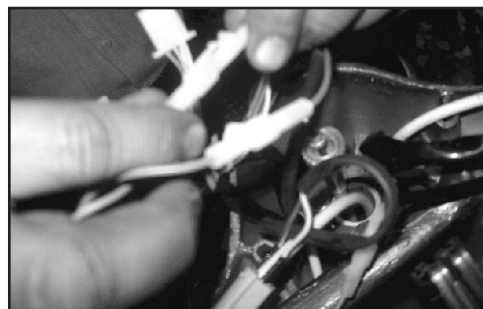

Fig. C

Open the (steering column) bolt to remove handle bar.

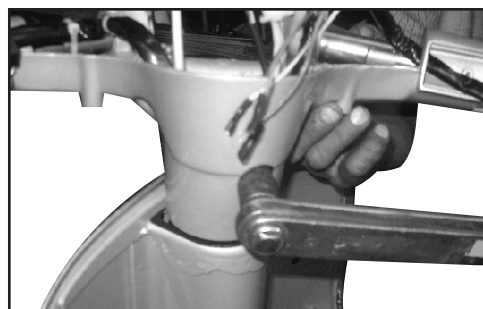

Fig. D

Turn handle bar bottom assembly in front direction.

Place Tool No. **H-3391533** on the ring nut and open 'D'  
Fig. E.

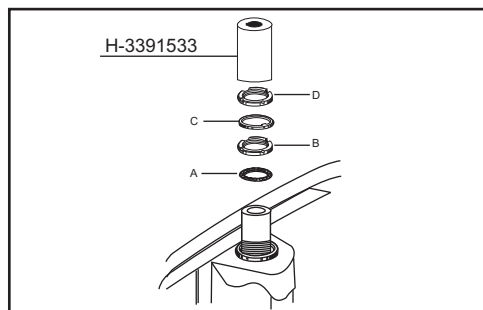

Fig. E

Take out the stop washer 'C'.  
Fig. E.

## STEERING COLUMN

Again with the same tool open the upper track 'B' and take out the ball cage.

### NOTE :

Hold steering column while opening the track to avoid damages to threads.

In order to remove steering column assembly hold the chassis and pull out the steering column assy. alongwith front wheel assy.

Fig. A.

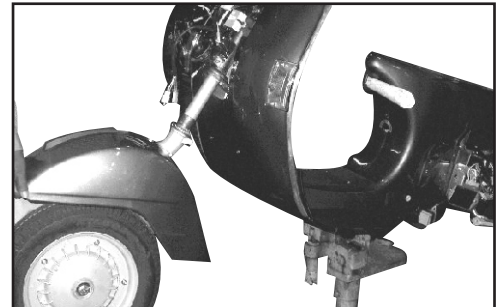

Fig. A

Insert Tool No. **H-1391534** from lower end and punch out the lower track of upper bearing from the chassis steering column tube.

Fig. 'B'

Insert the Tool No. **H-1391535** from top side of chassis steering column tube and punch out outer track 'Z' of lower bearing.

Fig. C.

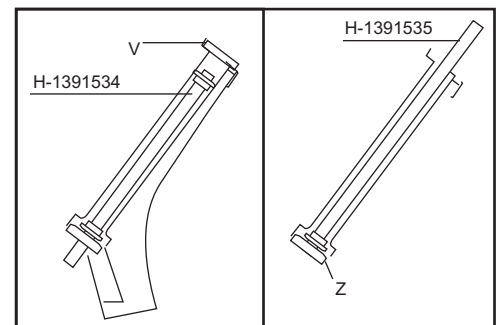

Fig. B

Fig. C

Remove the ball cage extract the inner race of lower bearing by extractor Tool No. **H-1391536** and remove dust cover.

Fig. D.

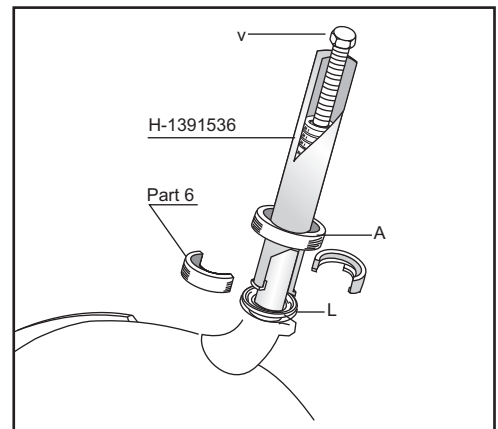

Fig. D

## STEERING COLUMN

### INSPECTION

Check all tracks for any pitting or dents on the surface. Replace in sets, if required.

Fig. A.

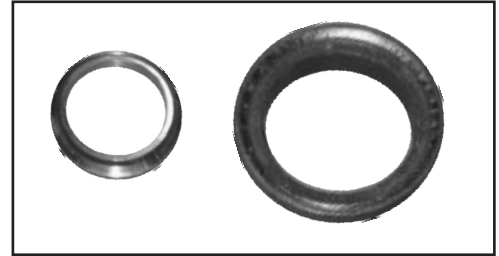

Fig. A

Inspect ball cages, if damaged, replace with new.

Fig. B.



Fig. B

Inspect the damage to threads in ring nut and tracks.

Fig. C.

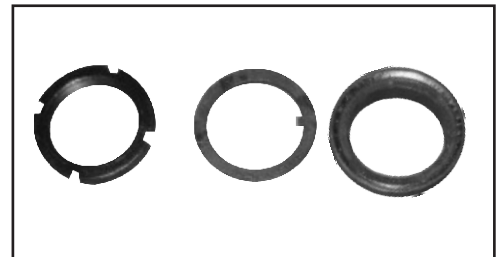

Fig. C

### INSTALLATION

For lower track of lower bearing, with the help of Tool No **H-2391537** punch, inner track 'S' with dust cover 'P' on steering column.

Fig. D.

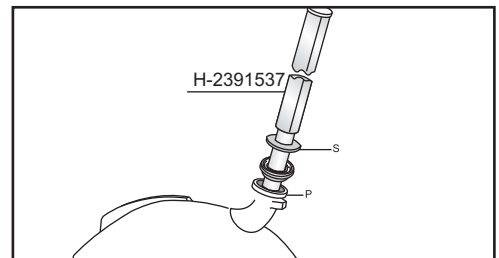

Fig. D

Fit Tool No. **H-2391538** with upper track 'B' of lower bearing on 'X' and insert into steering column tube. Fit 'A' lower track of upper bearing on top side. Apply grease on both upper and lower bearing tracks and tighten nut 'D' till tracks seat properly in the respective location.

Fig. E.

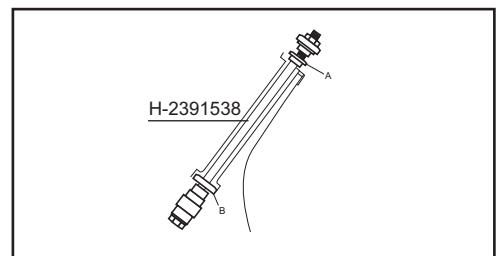

Fig. E

## STEERING COLUMN

Place lower ball cage with grease on lower track of lower bearing on steering column.

Fig. A.



Fig. A

Place upper ball cage on lower track of upper bearing with the help of grease.

Fig. B.

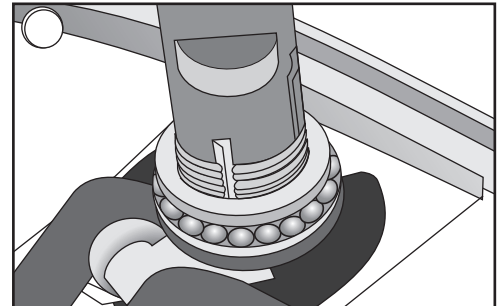

Fig. B

Insert steering from lower side passing through tracks and screw fit upper ring nut by hand so that steering column is properly located.

Fig. C.

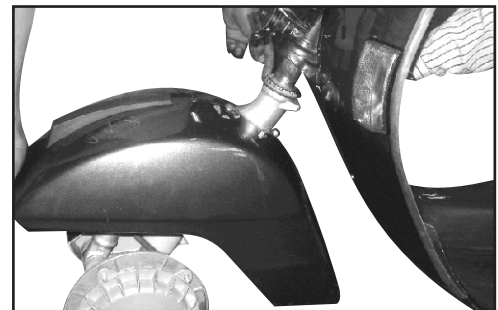

Fig. C

Place the duly greased upper track of upper bearing (ring nut).

### NOTE :

While inserting steering column take care that ball cages are not dislocated.

Tighten the upper track with Tool No. **H-3391533**

Fig. D.

Tightening torque - **5 to 6 kg-m.**

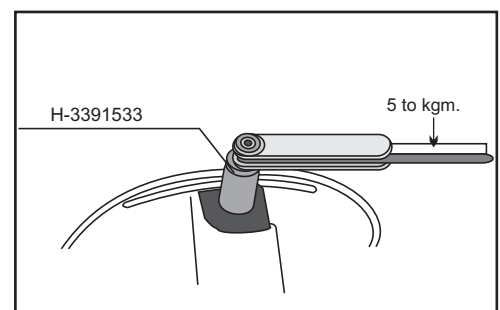

Fig. D

Loosen the track by turning 1/4th turn open 90°.

Fig. E.

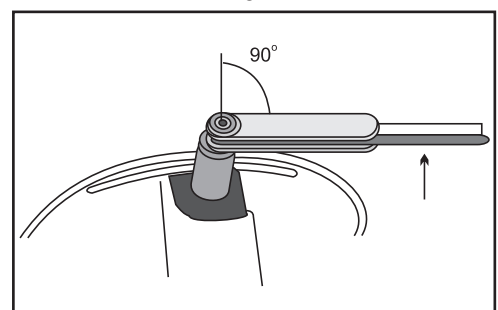

Fig. E

## STEERING COLUMN

Place stop washer 'C' and tighten top ring nut 'D'

Tightening Torque - **3 to 4 kg-m.**

Check steering column for free rotation and without vertical play on its weight. This can be checked by lifting the steering column upwards. For correction loosen ring nut and upper track and follow above tightening procedure again.



Fig. A

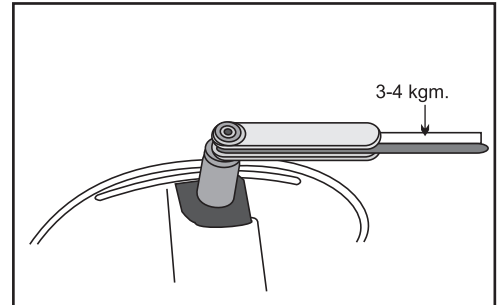

Fig. B

---

## TROUBLE SHOOTING

### CHECK SEQUENCE

#### • ENGINE STARTING TROUBLE

(CHECK IGNITION SWITCH "ON" POSITION)

		<b>Probable Cause</b>
1.	Check if fuel is getting to carburettor by loosening drain screw	
	Getting to carburettor ↓	
	Not getting to carburettor →	<ul style="list-style-type: none"><li>- Fuel cock 'OFF' position</li><li>- No fuel in fuel tank</li><li>- Clogged fuel line</li><li>- Clogged fuel strainer</li><li>- Clogged fuel filter</li><li>- Sticking float valve</li><li>- Clogged fuel tank cap - breather hole</li></ul>
2.	Perform spark test	
	Good spark ↓	
	Weak or no spark →	<ul style="list-style-type: none"><li>- Faulty spark plug</li><li>- Fouled spark plug</li><li>- Broken or shorted spark plug wire</li><li>- Faulty ignition switch</li><li>- Poorly connected, broken or shorted Ignition system wires</li><li>- Faulty CDI unit</li><li>- Faulty charging coil</li><li>- Faulty pick-up coil</li></ul>
3.	Start by following normal starting procedure	
	Engine does not start ↓	
	Engine starts but soon stops →	<ul style="list-style-type: none"><li>- Mis-adjusted idle speed</li><li>- Clogged carburettor</li><li>- Improper ignition timing</li><li>- Air-fuel mixture too lean</li></ul>
4.	Remove and check spark plug	
	Dry spark plug ↓	
	Wet spark plug →	<ul style="list-style-type: none"><li>- Carburettor choke excessively closed</li><li>- Flooded carburettor</li><li>- Air-fuel mixture too rich</li><li>- Dirty air cleaner element</li><li>- Oil entry into combustion chamber</li></ul>
5.	Test cylinder compression	
	Normal compression ↓	
	Low compression →	<ul style="list-style-type: none"><li>- Incorrect valve seat contact</li><li>- Valve clearance too small</li><li>- Valve stuck open</li><li>- Worn cylinder and piston</li><li>- Damaged Cylinder head gasket</li><li>- Seized valve</li><li>- Improper valve timing</li></ul>
6.	Start with application of choke	



## CHECK SEQUENCE

---

### • ENGINE LACKS POWER

		<b>Probable Cause</b>
1.	Raise wheels off ground and spin by hand  Wheels spin freely ↓	Wheels do not spin freely → <ul style="list-style-type: none"> <li>- Brake dragging</li> <li>- Worn or damaged wheel bearing</li> <li>- Wheel bearing needs lubrication</li> </ul>
2.	Check tyre pressure  Normal pressure ↓	Pressure too low → <ul style="list-style-type: none"> <li>- Punctured tyre</li> <li>- Faulty tyre valve</li> </ul>
3.	Check carburettor for clogging  Not Clogged ↓	Clogged → <ul style="list-style-type: none"> <li>- Carburettor not serviced frequently enough</li> </ul>
4.	Lightly accelerate engine  Engine speed increases ↓	Engine speed does not increase sufficiently → <ul style="list-style-type: none"> <li>- Air-fuel mixture too rich or lean</li> <li>- Clogged air cleaner</li> <li>- Restricted fuel flow</li> <li>- Clogged fuel tank cap breather hole</li> <li>- Clogged muffler</li> </ul>
5.	Remove and check spark plug  Good condition ↓	Fouled or discoloured → <ul style="list-style-type: none"> <li>- Spark plug not serviced frequently enough</li> <li>- Use of spark plug with improper heat range</li> </ul>
6.	Remove dipstick and check oil level and condition  Correct ↓	Incorrect → <ul style="list-style-type: none"> <li>- Oil level too high</li> <li>- Oil level too low</li> <li>- Contaminated oil</li> </ul>
7.	Check ignition timing  Correct ↓	Incorrect → <ul style="list-style-type: none"> <li>- Faulty CDI unit</li> <li>- Faulty pick-up coil</li> <li>- Improperly installed pick-up coil</li> </ul>
8.	Check for clutch slipping  Clutch does not slip ↓	Clutch slips → <ul style="list-style-type: none"> <li>- Weak clutch springs</li> <li>- Worn clutch discs</li> <li>- Warped clutch plates</li> <li>- Misadjusted clutch lever free play</li> <li>- Sticky clutch lifter mechanism</li> </ul>
9.	Check if engine overheats  Engine does not overheat ↓	Engine overheats → <ul style="list-style-type: none"> <li>- Excessive carbon built-up in combustion-chamber</li> <li>- Use of improper quality of fuel / engine oil</li> <li>- Clutch slipping</li> <li>- Air-fuel mixture too lean</li> <li>- Low level of engine oil</li> </ul>

<p>10. Test cylinder compression</p> <p>Normal compression</p> <p style="text-align: center;">↓</p>	<p>Low Compression →</p>	<p><b>Probable Cause</b></p> <ul style="list-style-type: none"> <li>- Incorrect valve seat contact</li> <li>- Valve clearance too small</li> <li>- Worn cylinder and piston rings</li> <li>- Damaged cylinder head gasket</li> <li>- Improper valve timing</li> </ul>
<p>11. Remove cylinder head cover and inspect lubrication</p> <p>Valve train lubricated properly</p> <p style="text-align: center;">↓</p>	<p>Valve train not lubricated Properly →</p>	<ul style="list-style-type: none"> <li>- Clogged oil passage</li> <li>- Faulty oil pump</li> <li>- Clogged oil strainer or filter paper element</li> </ul>
<p>12. Accelerate or run at high speed</p>	<p>Engine knocks →</p>	<ul style="list-style-type: none"> <li>- Excessive carbon built-up in combustion-chamber</li> <li>- Use of improper quality of fuel</li> <li>- Worn cylinder piston</li> <li>- Air-fuel mixture too lean</li> <li>- Faulty CDI unit</li> </ul>

**• POOR PERFORMANCE AT IDLE AND LOW SPEEDS**

<p>1. Check ignition timing &amp; valve clearance</p> <p>Correct</p> <p style="text-align: center;">↓</p>	<p>Incorrect →</p>	<ul style="list-style-type: none"> <li>- Faulty pick-up coil</li> <li>- Improperly adjusted valve clearance</li> <li>- Improperly installed pick-up coil</li> </ul>
<p>2. Check carburettor air screw adjustment</p> <p>Correct</p> <p style="text-align: center;">↓</p>	<p>Incorrect →</p>	<ul style="list-style-type: none"> <li>- Air-fuel mixture too lean</li> <li>- Air-fuel mixture too rich</li> </ul>
<p>3. Check for air leakage from carburettor gasket / packing</p> <p>Not leaking</p> <p style="text-align: center;">↓</p>	<p>Leakage →</p>	<ul style="list-style-type: none"> <li>- Loose carburettor bolts or improper fitment of insulator</li> <li>- Damaged carburettor insulator</li> </ul>
<p>4. Perform spark test</p> <p>Good spark</p> <p style="text-align: center;">↓</p>	<p>Weak or intermittent spark →</p>	<ul style="list-style-type: none"> <li>- Faulty spark plug</li> <li>- Fouled spark plug</li> <li>- Faulty CDI unit</li> <li>- Faulty Charging coil or pick-up coil</li> <li>- Faulty HT coil</li> <li>- Broken or shorted spark plug wire</li> <li>- Poorly connected, broken or shorted ignition system wires</li> </ul>
<p>5. Check carburettor for clogging</p>	<p>Clogged →</p>	<ul style="list-style-type: none"> <li>- Carburettor circuit choked</li> <li>- Carburettor jets choked</li> </ul>

## CHECK SEQUENCE

---

### • POOR PERFORMANCE AT HIGH SPEEDS

		<b>Probable Cause</b>
1.	Check ignition	Incorrect → - Faulty CDI unit - Faulty pick up coil - Improperly installed pick up coil
	Correct ↓	
2.	Disconnect fuel line of Carburettor	Fuel flow restricted → - Lack of fuel in fuel tank - Clogged fuel line - Clogged fuel strainer - Clogged fuel filter - Clogged fuel tank cap breather hole
	Fuel flows freely ↓	
3.	Check the carburettor jets for clogging	Clogged → - Clogged carburettor jets (Clean them)
	Not clogged ↓	
4.	Check valve timing	Incorrect → - Improperly installed cam sprocket
	Correct ↓	
5.	Check valve springs	Weak → - Faulty valve spring

---

### • POOR HANDLING

		<b>Probable Cause</b>
1.	If steering is heavy →	- Steering column track and ring nut for bearing adjustment too tight - Damaged steering column ball races and ball cages damage
2.	If either of wheel is wobbling →	- Excessive wheel bearing play - Bent rim - Loose engine mounting bolt in link of chassis - Loose bolt link to chassis
3.	If scooter pulls to one side →	- Front and rear wheels rims not aligned - Steering column damage. - Weak / leaking shock absorber

---

---

## TROUBLE SHOOTING

### TROUBLE SHOOTING - PROBLEMS

#### • FUEL SYSTEM

##### Engine won't start

- No Fuel to carburettor
- Fuel tank empty
- Fuel strainer clogged
- Fuel tube clogged
- Fuel tank cap breather hole clogged
- Fuel level incorrect
- Float valve stuck
- Too much fuel getting to the engine
- Air cleaner clogged
- Carburettor flooded
- Fuel deteriorated / contaminated

##### Lean Mixture

- Float level too low
- Intake Air leakage
- Fuel line restricted
- Carburettor Air vent tube clogged / bent
- Throttle valve faulty
- Fuel jets clogged
- Carburettor not tuned properly

##### Rich Mixture

- Choke valve in "ON" position
- Float level too high
- Emulsifier clogged
- Air cleaner element clogged
- Flooded carburettor
- Carburettor not tuned properly

##### Engine Stalls, Hard to start, Rough Idling

- Fuel lines restricted
- Ignition malfunction
- Fuel mixture too lean / rich (air screw adjustment)
- Fuel contaminated / deteriorated
- Intake air leak
- Idle speed too low
- Float level incorrect
- Fuel tank breather hole clogged
- Fuel tube clogged

##### Poor Performance (Driveability) and Poor Fuel Economy

- Fuel system clogged
- Ignition system malfunctioning

#### • CYLINDER HEAD / VALVES

- Engine top-end problems usually affect engine performance. These can be diagnosed by a compression or leak down test.

- If performance is poor at low speeds check for white smoke in the crankcase breather tube . If white smoke comes out from breather tube, check for seized piston rings.

##### Low Compression, Hard Starting or Poor Performance at Low Speed

###### Valves

- Incorrect valve adjustment
- Burn or bent valves
- Incorrect valve timing
- Broken valve spring
- Weak valve spring

###### Cylinder head

- Leaking or damaged head gasket
- Warped or cracked cylinder head
- Faulty cylinder or piston

##### Compression High,Overheating or Knocking

- Excessive carbon built-up in cylinder head or on top of piston

##### Excessive Smoke → Cylinder head

- Worn valve stem or valve guide
- Damaged valve stem seal
- Faulty cylinder or piston / rings

##### Excessive Noise → Cylinder head

- Incorrect valve adjustment
- Sticking valve or broken valve spring
- Damaged or worn cam shaft
- Loose or worn silent chain
- Worn or damaged silent chain
- Worn cam sprocket teeth
- Worn or damaged silent chain tensioner
- Worn rocker arm or shaft
- Faulty cylinder or piston

##### Rough Idle

- Low cylinder compression
- Intake air leak
- Clogged fuel system
- Improper tuning

## TROUBLE SHOOTING - PROBLEMS

### • CYLINDER / PISTON

- Low or unstable compression
- Worn cylinder or piston ring

#### **Excessive Smoke**

- Worn cylinder, piston or piston ring
- Improper installation of piston ring
- Scored or scratched piston or cylinder wall

#### **Overheating**

- Excessive carbon built-up on piston or combustion chamber

#### **Knocking or abnormal noise**

- Worn piston and cylinder
- Excessive carbon built-up
- Petrol quality not good

### • CLUTCH/GEAR SHIFT

#### **Clutch**

Scooter Creeps with the Engine Idling

- Incorrect clutch adjustment
- Clutch plates warpage
- Loose clutch lock nut
- Excessive oil in the crankcase
- Improper grade ( viscosity ) of engine oil
- Improper clutch lever installation

#### **Clutch Slips, when Accelerating**

- Incorrect clutch adjustment
- Wornout clutch plate/friction plate
- Weak clutch springs
- Contaminated engine oil

#### **Gearshift**

#### **Hard to Shift**

- Incorrect clutch adjustment
  - Direction of speed gears not correct.
  - Movement of selector spider on drive shaft not free.
- It should be free in neutral gear.

### • SILENT CHAIN

#### **Silent Chain Noise**

- Weak or damaged tensioner
- Damaged tensioner head
- Faulty silent chain guide

#### **Excessive chain slack**

- Weak or damaged chain tensioner
- Elongated silent chain

### • TRANSMISSION/CRANK SHAFT/KICK STARTER

#### **Excessive Noise**

- Worn crankshaft main bearing in crank case
- Worn transmission bearings
- Worn crank big end bearing or pin

#### **Engine Vibration**

- Excessive crank shaft runout
- Loose rubber grommet of link assy.

### **Poor Brake Performance**

- Improperly adjusted brake
- Worn brake linings
- Worn brake drum
- Worn out shaft for brake lever
- Improper installation of brake shoes
- Brake cable sticking / needs lubrication
- Contaminated brake drum
- Worn brake shoes at contact area

### **Brake Lever Hard or Slow Return**

- Weak / Broken return spring
- Improperly adjusted brake
- Sticking brake drum due to contamination
- Worn brake shoes at cam contact area of shaft for brake lever
- Brake cable sticking / needs lubrication
- Improper installation of brake shoes

### **Brake Squeaks**

- Worn brake shoes
- Worn brake drum
- Contaminated brake drum/shoes
- Moisture/water in brake drum

### **Soft Suspension**

- Weak front shock absorber
- Leakage in shock absorber

### **Hard Steering**

- Steering upper ring nut too tight
- Damaged steering ball races
- Insufficient tyre pressure
- Faulty tyre
- Bent steering column
- Faulty front damper
- Condition of DC roller bearings of suspension link bad
- Wheel nut improperly tightened

### **Steers to one side or does not rotate freely**

- Bent steering column
- Tyres on front wheel not correct.
- Bent frame (accident)
- Faulty steering ball races
- Faulty wheel bearing
- Link-Engine bolt not tightened properly/loose

### **Soft Suspension (Rear)**

- Spring loading not done properly
- Oil leakage from damper unit

## TROUBLE SHOOTING - PROBLEMS

### • LIGHTING / BATTERY CHARGING SYSTEM

#### **Battery not charged**

- Shorted wire harness
- No battery electrolyte
- Fully discharge of battery
- Faulty RR unit
- Faulty contact of main fuse or blown
- Faulty ignition switch
- Faulty battery charging coils

#### **Low voltage**

- Insufficient battery charge
- Low level of battery electrolyte
- Battery discharge
- Faulty charging system
- Faulty contact

#### **Current Failure**

- Faulty contact of battery cable
- Faulty contact of charging system
- Faulty contact of starting system
- Faulty contact or short in ignition switch
- Faulty contact or short in lighting system

#### **Faulty charging system**

- Faulty contact, disconnection or short of wire or connector
- Faulty regulator cum rectifier
- Faulty magneto

#### **Bulbs fusing oftenly**

- Loose connection or short in wires
- Faulty regulator cum rectifier
- Faulty lighting / battery charging coils

#### **Headlight dim**

- Poor earthing connection
- Faulty regulator cum rectifier
- Faulty lighting / battery charging coils

### • AUTO ELECTRIC START SYSTEM (Optional)

#### **Starter motor does not turn**

- Blown fuse
- Loose starter motor cable
- Battery discharged
- Battery terminal loose

#### **Press start button - Click heard**

- Apply battery voltage to the starter motor directly & check its operation
- Faulty wire connection
- Faulty cut-out relay
- Faulty starter motor

#### **Press start button - Click not heard**

- Faulty start push button
- Check cut-out relay voltage
- Faulty ignition switch or de-clutch switch

#### **Battery voltage**

- Check cut-out relay for continuity
- Cut-out relay may be faulty

#### **For abnormal continuity**

- Faulty start push button connection
- Faulty de-clutch switch

#### **Starter motor turns but engine turns slowly**

- Low sp. gravity of battery electrolyte
- Excessive resistance in the circuit
- Winding in starter motor

#### **Starter motor & engine turns but engine does not start**

- Faulty CDI
- Engine problems - low compression

**NOTE :** THE STARTER MOTOR CAN BE OPERATED WHEN THE IGNITION SWITCH IS IN "ON" POSITION AND BY PRESSING STARTER PUSH BUTTON WITH DECLUTCH.

---

## NOTES



---

## NOTES



5400 N. Damen Ave. Chicago, IL 60625  
Ph: 773-271-8546, Fax: 773-271-8518, [www.genuinescooters.com](http://www.genuinescooters.com)